

CoolMachines^{Inc.}

BY **DAVE KRENDL**

Fiber Machines
Cutting Edge **COOL**



CM 2400

All-Fiber: Attic Blow, Dense-Pack (retro-fit)
SideWall, Wall Spray, Fireproofing.

Material	Production Rate/hr
Cellulose	3000 lbs *
Fiberglass	900 lbs*
Rockwool	1800 lbs

*16" airlock produces 3600 lbs./hr. cellulose (100 ft)
*16" airlock produces 1300 lbs./hr. fiberglass

STANDARD FEATURES AND BENEFITS

Mechanical

- Large 15 cu./ft. hopper capacity fiber storage. (optional 30cu.ft. or 40 cu.ft extension hopper).
- Stainless slide-gate and integrally mounted 'pressue gauge' provides precise fiber control.
- High quality powder coating provides a long lasting corrosion resistant finish.
- Modular design with see-thru access panels for quick troubleshooting and maintenance.
- Slow speed positive feed 'scalping' augers extend component life, while increasing safety.
- Large 12" X 12" (optional 16"), quick release airlock is a durable, easily serviced component.
- High speed stainless turbo-shredder maximizes fiber conditioning, coverage, and production.
- High torque (1250 in./lb.) motor/reducer drive provides surplus power.
- #50 chain and hardened sprockets, are rugged, corrosion resistant, and positive driving.
- Two integrally mounted 3-stage blowers w/check valve protection, outside air tube for reduced filter maintenance. (optional four blower or P.D. blower)
- 150 ft. 3-function remote cord w/cord hanger, offers convenient handling of remote device.

Electrical

- Safety Features: kill switch and manual override controls promote increased operator safety and quick hazard response.
- 'Panel' mounted manual thermal overload protection of all motors and electrical components.
- Deluxe voltmeter, L.E.D. 'lighted' plugs and reptacles for quick electrical diagnostics.

CM 2400 SPECIFICATIONS

Weight

720 lbs.(2-blower)

Dimensions

58" L x 22" W x 48" H

Hopper Capacity

Main Hopper: 15 cu./ft.
(3 bags)
w/Hopper Extension:
30cu/ft. (6 bags)
40cu/ft. (8 bags)

Airlock

12" long x 12" diameter
3" output for blowing hose
Slide-out airlock

Blower

Two,2-stage (120volt 8amp)
Two,3-stage (120volt 12.5amp)
Four,3-stage(120volt 12.5amp.)
5 h.p. P.D. blower

Power Requirements

Double input, 20/30 amps. 120 volt. or
Single input, 30 amp. 240 volt.
(two 3-stage blowers)

Single input, 40 amp. 240 volt.
(four 3-stage blowers or 5 h.p.
P.D. blower)

Generator Size

8,000 watt (2-blower)
15,000 watt (4-blower or 5 h.p.
P.D. blower)

Options

Blowers
16" airlock upgrade
Hopper Extension
Wheel Package w/Brackets
Wireless Remote
Hose reels

BENEFITS

The 2400 series machine provides an economical, high production machine with low power requirements and reduced weight/size in your truck/trailer system. The simple design and minimal moving parts provide a machine that is low maintenance and easy to repair.

This compact, **robust** machine with its various options, will out-perform and out-last any machine in its class.

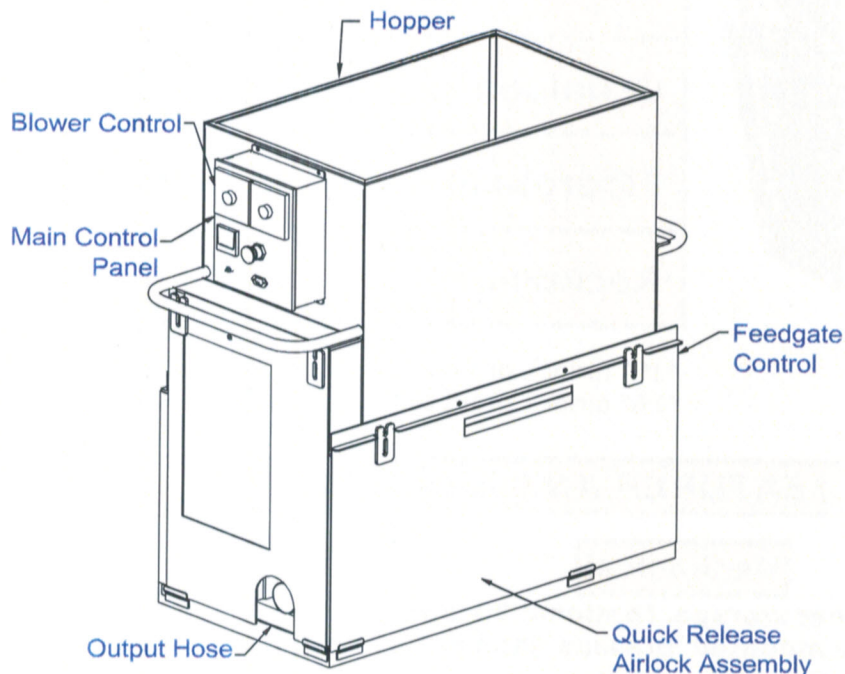

COOL People

President - Dave Krendl
Ofc: 419.232.4871
dave@coolmachines.com

General Manager - Andy Schulte
Ofc: 419.232.4871
andy@coolmachines.com

24/7 Tech Support:
Ofc: 419.232.4871
support@coolmachines.com