

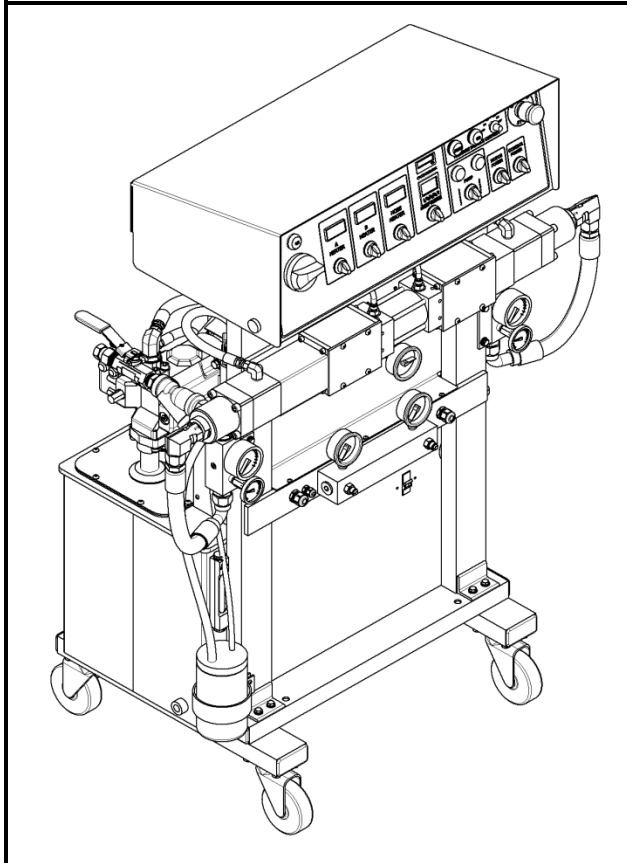

POLYURETHANE MACHINERY CORPORATION



PH/PHX-2 Proportioner

For Professional Use Only
Not approved for use in European
explosive atmosphere locations

Electrical Diagrams
Ref. # MN-04011

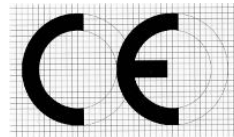

REVISION 1.0

Polyurethane Machinery Corp.

Corporate: 1 KOMO Drive, Lakewood, NJ 08701

Manufacturing: 2 KOMO Drive, Lakewood, NJ 08701

Phone: 732-415-4400

Fax: 732-364-4025

<http://www.polymac-usa.com>



Before installing the PH Series Proportioner and start-up, carefully read all the technical and safety documentation included in this manual. Pay special attention to the information in order to know and understand the operation and the conditions of use of the PH Series Proportioner. All of the information is aimed at improving user safety and avoiding possible breakdowns from the incorrect use of the PH Series Proportioner.

TABLE OF CONTENTS

WARRANTY	1
SAFETY AND HANDLING.....	3
220 VAC – 1 PHASE	5
Component Identification	5
Front Panel	5
Bottom Plate	7
Point to Point Diagrams	10
Incoming Power.....	10
Heater Circuit	11
Motor Circuit	12
24 VDC Power Circuit	13
Pump Circuit	14
Pressure Balance Control Circuit	15
Ladder Diagrams	16
Incoming Power.....	16
Heater Circuit	17
Motor Circuit	18
24 VDC Power Circuit	19
Pump Circuit	20
Pressure Balance Control Circuit	21
220 VAC – 3 PHASE	22
Component Identification	22
Front Panel	22
Bottom Plate	24
Point to Point Diagrams	27
Incoming Power.....	27
Heater Circuit	28
Motor Circuit	29
24 VDC Power Circuit	30
Pump Circuit	31
Pressure Balance Control Circuit	32
Ladder Diagrams	33
Incoming Power.....	33
Heater Circuit	34
Motor Circuit	35
24 VDC Power Circuit	36
Pump Circuit	37
Pressure Balance Control Circuit	38

380 VAC	39
Component Identification	39
Front Panel	39
Bottom Plate	41
Point to Point Diagrams	44
Incoming Power	44
Heater Circuit	45
Motor Circuit	46
24 VDC Power Circuit	47
Pump Circuit	48
Pressure Balance Control Circuit	49
Ladder Diagrams	50
Incoming Power	50
Heater Circuit	51
Motor Circuit	52
24 VDC Power Circuit	53
Pump Circuit	54
Pressure Balance Control Circuit	55
 MANUAL REVISIONS.....	 56

WARRANTY

Polyurethane Machinery Corporation (hereinafter "PMC") provides this LIMITED WARRANTY (hereinafter "Warranty") to the original purchaser (hereinafter "Customer") covering this equipment and the original PMC manufactured accessories delivered with the equipment (hereinafter "Product") against defects in material or workmanship of the Product (hereinafter "Defect" or "Defective") for a period of one (1) year from the date of first purchase as shown on the original PMC invoice (hereinafter "Warranty Period").

If during the Warranty Period under normal use, the Product is suspected by Customer to be Defective in material or workmanship, it is Customer's responsibility to contact PMC and return the Product to PMC as directed by PMC, freight prepaid. If PMC determines that the Product is Defective and that such Defect is covered by this Warranty, PMC will credit Customer for the reasonable freight charges incurred by Customer in returning the Defective Product to PMC, and PMC (or its authorized agent) will, at PMC's option, repair or replace the Product, subject to the following:

Original Invoice: The original invoice must be kept as proof of the date of first sale and the Product serial number. The Warranty does not cover any Product if the Original Invoice appears to have been modified or altered, or when the serial number on the Product appears to have been altered or defaced.

Product Maintenance: It is the Customer's responsibility to maintain the Product properly. See your maintenance schedule and owner's manual for details. The Warranty does not cover an improperly maintained Product.

Non-PMC Components and Accessories: Non-PMC manufactured components and accessories that are used in the operation of the Product are not covered by this Warranty. Such components and accessories shall be subject to the warranty offered to the Customer, if any, by the original manufacturer of such component or accessory.

Other Warranty Exclusions: The Warranty does not cover any Product that PMC determines has been damaged or fails to operate properly due to misuse, negligence, abuse, carelessness, neglect, or accident. By way of example only, this includes:

- Normal wear and tear.
- Improper or unauthorized installation, repair, alteration, adjustment or modification of the Product.
- Use of heating devices, pumping equipment, dispensers, or other parts or accessories with the Product that have not been approved or manufactured by PMC.
- Failure to follow the operating instructions and recommendations provided by PMC.
- Cosmetic damage.
- Fire, flood, "acts of God," or other contingencies beyond the control of PMC.

WARRANTY

THE WARRANTY DESCRIBED HEREIN IS THE EXCLUSIVE REMEDY FOR THE CUSTOMER AND IS IN LIEU OF ALL OTHER WARRANTIES, EXPRESS, IMPLIED, STATUTORY OR OTHERWISE, AND THE IMPLIED WARRANTIES OF MERCHANTABILITY AND FITNESS FOR A PARTICULAR PURPOSE AND ALL OTHER WARRANTIES ARE HEREBY DISCLAIMED. TO THE FULLEST EXTENT PERMITTED BY LAW, PMC SHALL NOT BE RESPONSIBLE, WHETHER BASED IN CONTRACT, TORT (INCLUDING, WITHOUT LIMITATION, NEGLIGENCE), WARRANTY OR ANY OTHER LEGAL OR EQUITABLE GROUNDS, FOR ANY CONSEQUENTIAL, INDIRECT, INCIDENTAL, LOST PROFITS, SPECIAL, PUNITIVE OR EXEMPLARY DAMAGES, WHETHER TO PERSON OR PROPERTY, ARISING FROM OR RELATING TO THE PRODUCT, EVEN IF PMC HAS BEEN ADVISED OF THE POSSIBILITY OF SUCH LOSSES OR DAMAGES.

Non-Warranty Service by PMC: If PMC determines that the suspected Defect of the Product is not covered by this Warranty, disposition of the Product will be made pursuant to the terms and conditions of PMC's written estimate on a time and materials basis.

Continuing Warranty for Products Repaired or Replaced under Warranty: Following the repair or replacement of a Product covered by this Warranty, such Product will continue to be subject to the original Warranty for the remainder of original Warranty Period or for three (3) months from the repair or replacement date, whichever is longer.

No Rights Implied: Nothing in the sale, lease or rental of any Product by PMC shall be construed to grant any right, interest or license in or under any patent, trademark, copyright, trade secret or other proprietary right or material owned by anyone; nor does PMC encourage the infringement of same.

Exclusive Warranty: This writing is the final, complete, and exclusive expression of the Warranty covering the Product. Any statements made by PMC, its employees or agents that differ from the terms of this Warranty shall have no effect. It is expressly understood that Customer's acceptance of this Warranty, by performance or otherwise, is upon and subject solely to the terms and conditions hereof, and any additional or different terms and conditions proposed or expressed by Customer or anyone, whether in writing or otherwise, are null and void unless specifically agreed to in writing by an Officer of PMC.

SAFETY AND HANDLING

This chapter contains important information on the safety, handling, and use of your PH Series Console.



Before performing maintenance and starting up the PH Series Console, carefully read and comprehend all the technical and safety information included in this manual. The information is aimed at enhancing user safety and avoiding possible breakdowns caused by incorrect or improper use.

Always disconnect the console from the main power source before opening the console.

WARNING! Symbol is presented in front of information to alert of a situation that might cause serious injuries if the instructions are not followed.

CAUTION! Symbol is presented in front of information that indicates how to avoid damage to the Proportioner or how to avoid a situation that could cause minor injuries.

NOTE! Symbol is presented in front of relevant information of a procedure being carried out.

Careful study of this manual will enable the operator to understand the characteristics of the PH Series Console and the operating procedures. By following the instructions and recommendations contained herein, you will reduce the potential risk of accidents in the installation, use, or maintenance of the PH Series Console. You will also provide a better opportunity for increased output, incident-free operation for a longer time, and the possibility of detecting and resolving problems fast and simply.

Keep this Operations Manual for future consultation of useful information at all times. If you lose this manual, ask for a new copy from your PMC authorized distributor or go online at our web site (www.polymac-usa.com).

When working with the PH Series Console, it is recommended that the operator wear suitable clothing and elements of personal protection, including, without limitation, gloves, protective goggles, safety footwear and face masks. Use breathing equipment when working with the PH Series Proportioner in enclosed spaces or in areas with insufficient ventilation. The introduction and follow-up of safety measures must not be limited to those described in this manual. Before starting up the PH Series Proportioner, a comprehensive analysis must be made of the risks derived from the products to be dispensed, the type of application and the working environment.

SAFETY AND HANDLING



To prevent possible injury caused by incorrect handling of the raw materials and solvents used in the process, carefully read the Material Safety Data Sheet (MSDS) provided by your supplier.

Deal with waste caused according to current regulations.

Pour éviter toute blessure causée par une mauvaise manipulation des matières premières et les solvants utilisés dans le processus, veuillez lire attentivement la fiche signalétique (MSDS) fournies par votre fournisseur.



To avoid damage caused by the impact of pressurized fluids, do not open any connection or perform maintenance work on the components subject to pressure until the pressure has been completely eliminated.

Pour éviter les dommages causés par l'impact des fluides sous pression, ne pas ouvrir un lien ou d'effectuer des travaux d'entretien sur les éléments soumis à la pression jusqu'à ce que la pression a été complètement éliminé.



Use suitable protection when operating, maintaining or being present in the area where the equipment is functioning. This includes, but is not limited to, the use of protective goggles, gloves, shoes and safety clothing and breathing equipment.



Utiliser une protection appropriée utilisation, d'entretien ou d'être présents dans la région où le matériel fonctionne. Cela inclut, mais n'est pas limité à, l'utilisation de lunettes de protection, gants, chaussures et vêtements de sécurité et un équipement respiratoire.



The equipment includes components that reach high temperatures and can cause burns. Hot parts of the equipment must NOT be handled or touched until they have cooled completely.

L'équipement comprend des éléments qui atteignent des températures élevées et peuvent provoquer des brûlures. Les parties chaudes de l'équipement ne doit pas être manipulé ou touché jusqu'à ce qu'ils aient complètement refroidi.



To prevent serious injury through crushing or amputation, do not work with the equipment without the safety guards installed on the moving parts. Make sure that all the safety guards are correctly reinstalled at the end of the repair or maintenance work of the equipment.

L'équipement comprend des éléments qui atteignent des températures élevées et peuvent provoquer des brûlures. Les parties chaudes de l'équipement ne doit pas être manipulé ou touché jusqu'à ce qu'ils aient complètement refroidi.



220 VAC – 1 Phase

Component Identification

Front Panel

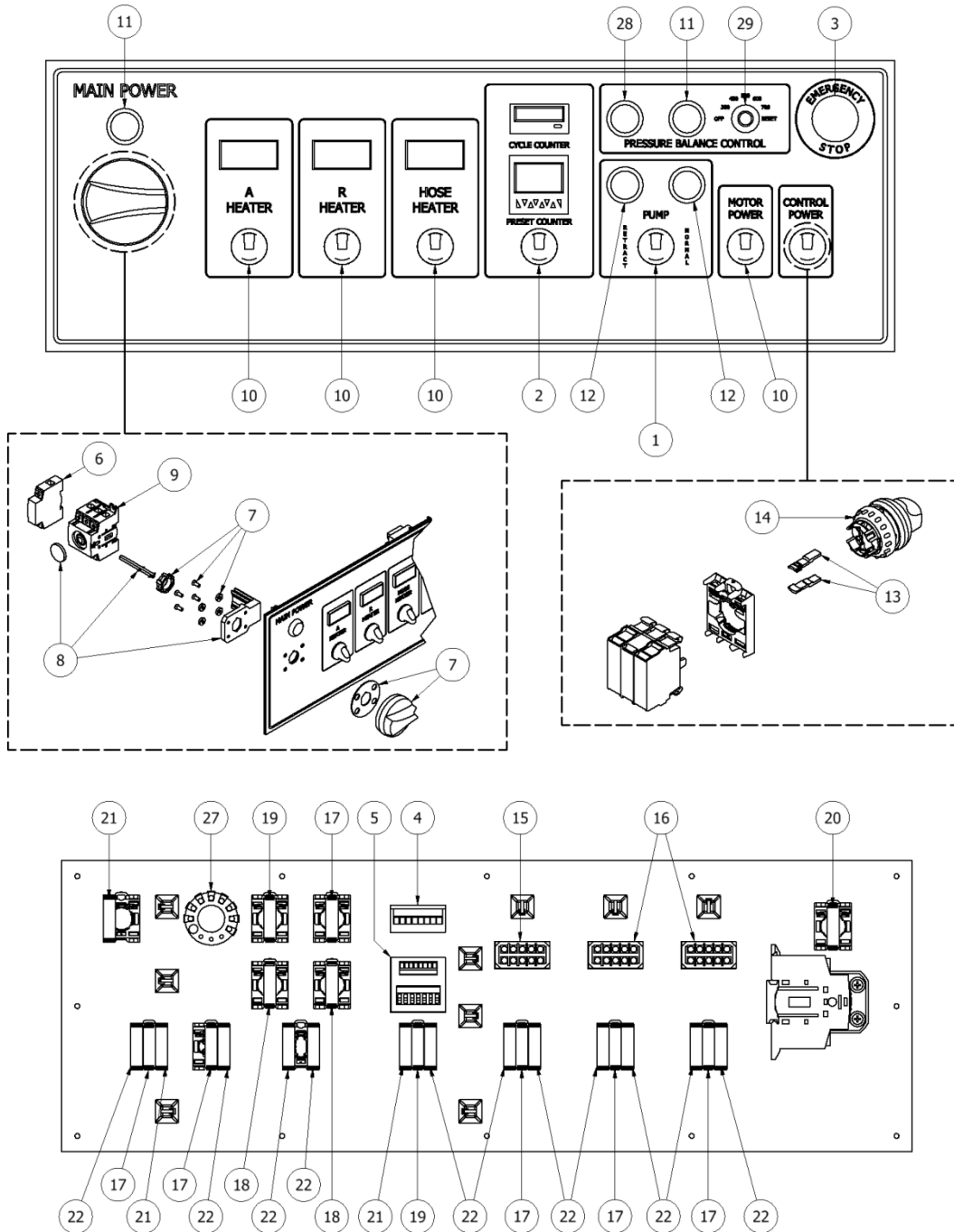

COMPONENT LIST			
ITEM	QTY	PART NUMBER	DESCRIPTION
1	1	EL-128-W	SELECTION SWITCH; 3 POS; WHT
2	1	EL-129-G	SELECTOR SWITCH; GREEN
3	1	EL-107	E-STOP PUSH TWIST
4	1	EL-124	TOTALIZER; BATT OP
5	1	EL-127	COUNTER
6	1	EL-101	SWITCHED MODULE; 80A; 1 POLE
7	1	EL-105	SELECTOR HANDLE; RED
8	1	EL-103	DOOR MOUNTING KIT
9	1	EL-100	ROTARY DISCONNECT; 80A; 3 POLE
10	4	EL-129-R	SELECTOR SWITCH; RED
11	2	EL-134	LIGHT SWITCH
		EL-135	GREEN LENS; "ON"
12	2	EL-134	LIGHT HOUSING
		EL-138	AMBER LENS; LEFT ARROW
13	1	EL-130	CODING ADAPTER
14	1	EL-128-R	SELECTOR SWITCH; 3 POS; RED
15	1	EL-T2	TEMPERATURE CONTROLLER; HOSE
16	2	EL-T1	TEMPERATURE CONTROLLER; PRE-HTR
17	6	EL-131-R	LIGHT UNIT; RED; 24VDC
18	2	EL-131-W	LIGHT UNIT; WHITE 24VDC
19	2	EL-131-G	LIGHT UNIT; GRN; 24VDC
20	1	EL-132-G	GREEN LIGHT UNIT
21	3	EL-133-NC	CONTACT BLOCK; NC
22	11	EL-133-NO	CONTACT BLOCK; NO
27	1	EL-196	ROTARY SWITCH 7POS
28	1	EL-134	LIGHT HOUSING
		EL-137-F	RED LENS; "FAULT"
29	1	EL-197	ROTARY SWITCH KNOB

Bottom Plate

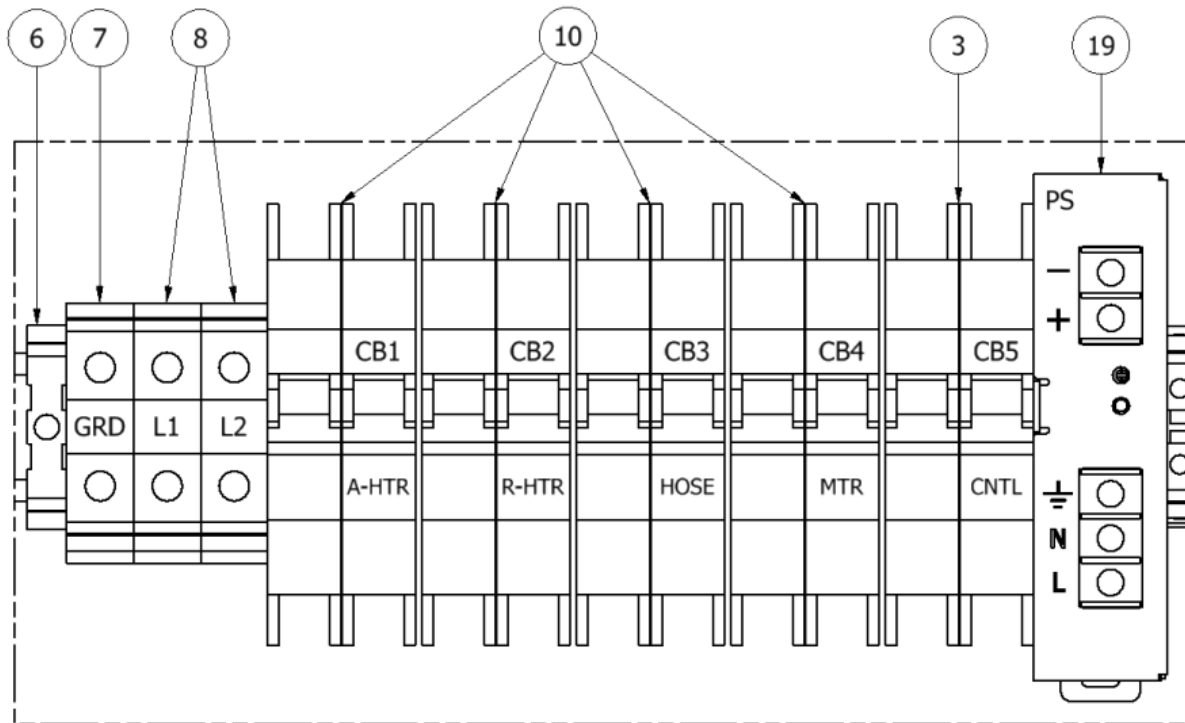
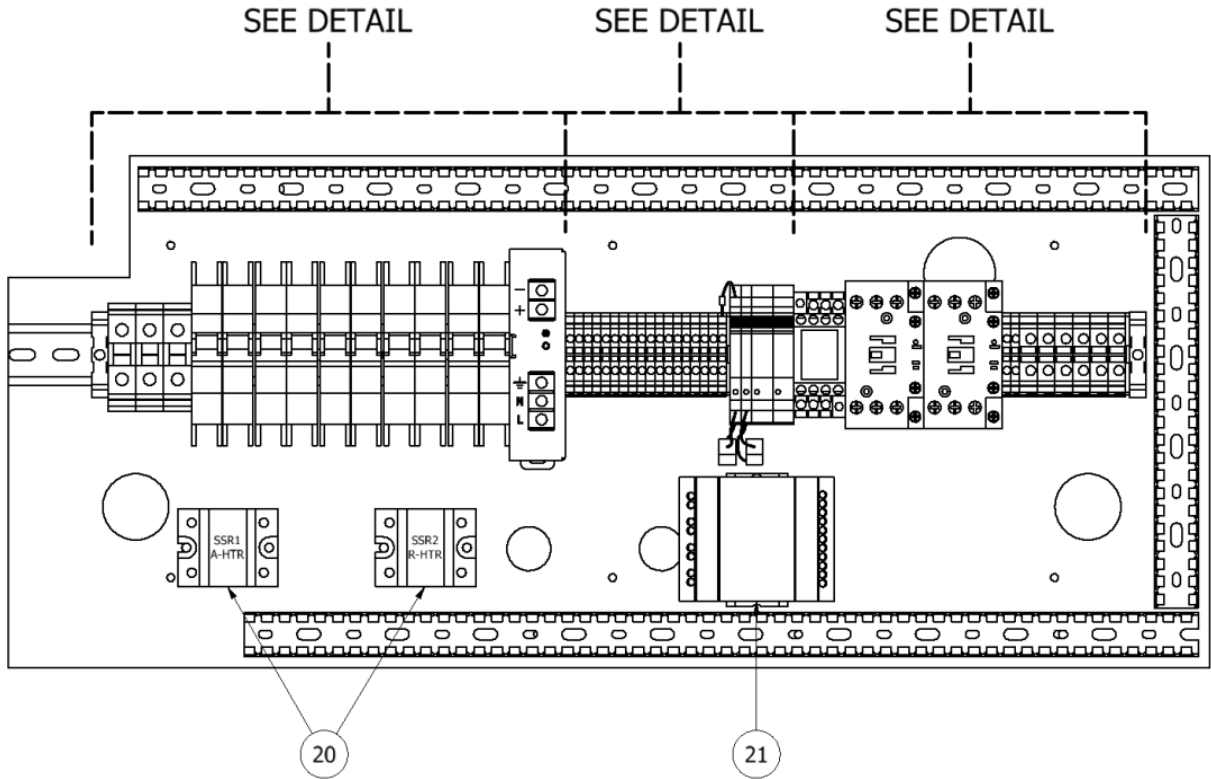

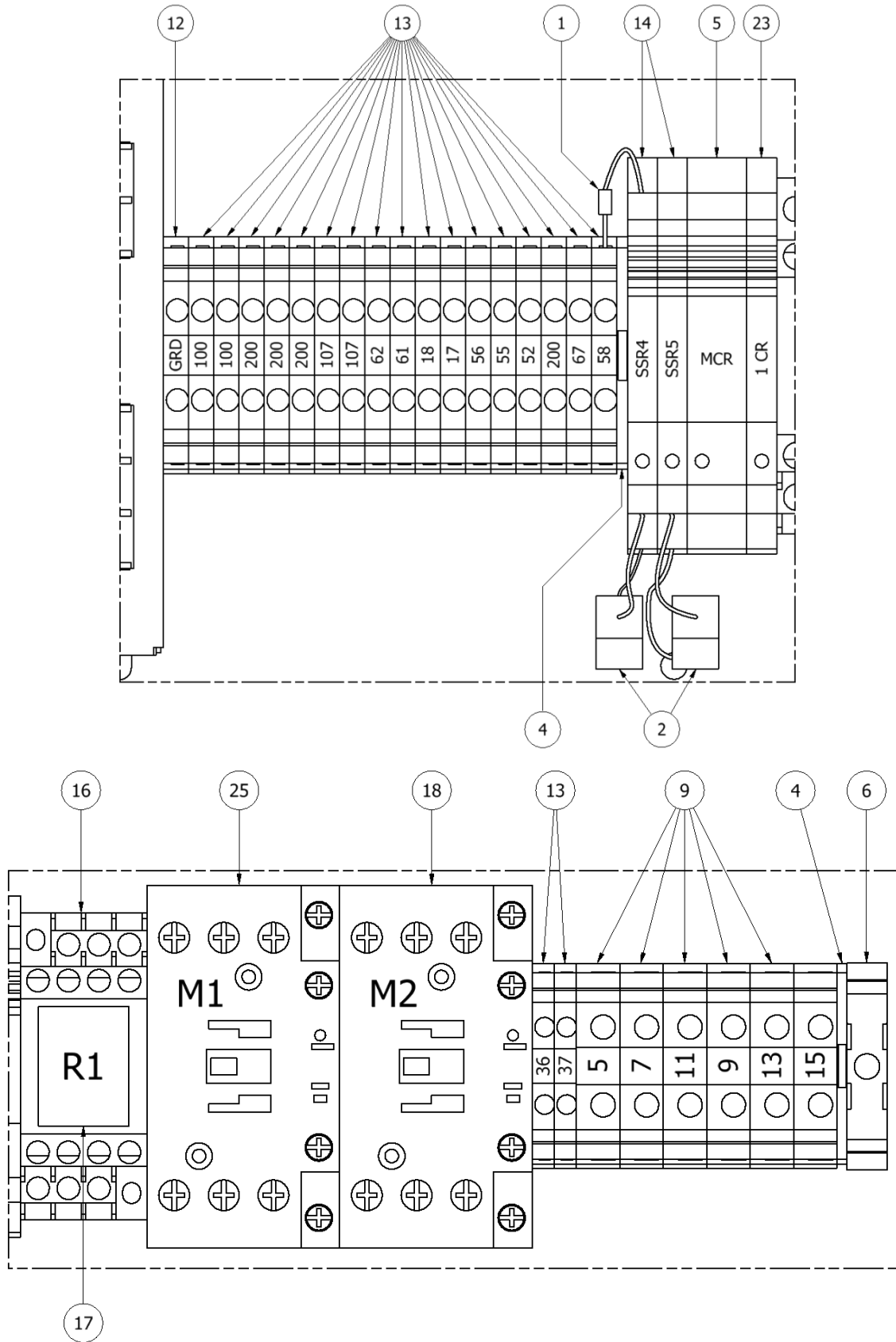

COMPONENT LIST			
ITEM	QTY	PART NUMBER	DESCRIPTION
1	1	EL-171	DIODE RECTIFIER; 1000V; 1A
2	2	EL-172	RESISTOR; 220 OHM; 5%; 3W; MET
3	1	EL-114	CIRCUIT BREAKER; 3A; 2 POLE; TYP
4	2	EL-156-10	TERMINAL COVER 10MM/5.2MM
5	1	EL-174	SS RELAY; 24 VDC
6	2	EL-152	END STOP; 35MM
7	1	EL-146	TERMINAL BLOCK; 16MM; GROUND
8	2	EL-143	TERMINAL BLOCK; 16MM
9	6	EL-141	TERMINAL BLOCK; 10.2MM
10	4	EL-188	BREAKER; 32A; 2 POLE
12	1	EL-144	TERMINAL BLOCK; 5.2MM; GRND
13	19	EL-140	TERMINAL BLOCK; 5.2MM
14	2	EL-160	SS RELAY; 24VDC; 2A
15	1	EL-119	CONTACTOR; 25A; 24VDC COIL
16	1	EL-155	RELAY SOCKET
17	1	EL-154	LATCHING RELAY; 24VDC
18	1	EL-118	CONTACTOR; 32A; 24VDC COIL (FOR 120V TRANSFORMER)
	1	EL-119	CONTACTOR; 25A; 24VDC COIL (FOR 90V & 70V TRANSFORMER)
19	1	EL-122	POWER SUPPLY; 2.5A; 230VAC/24VDC
20	2	EL-34	RELAY; 50 AMP; 480V
21	1	EL-194-1	BAL CONT UNIT
23	1	EL-198	RELAY; SPDT; 24 VDC
25	1	EL-125	CONTACTOR; 40A; 24VDC

Point to Point Diagrams

Incoming Power

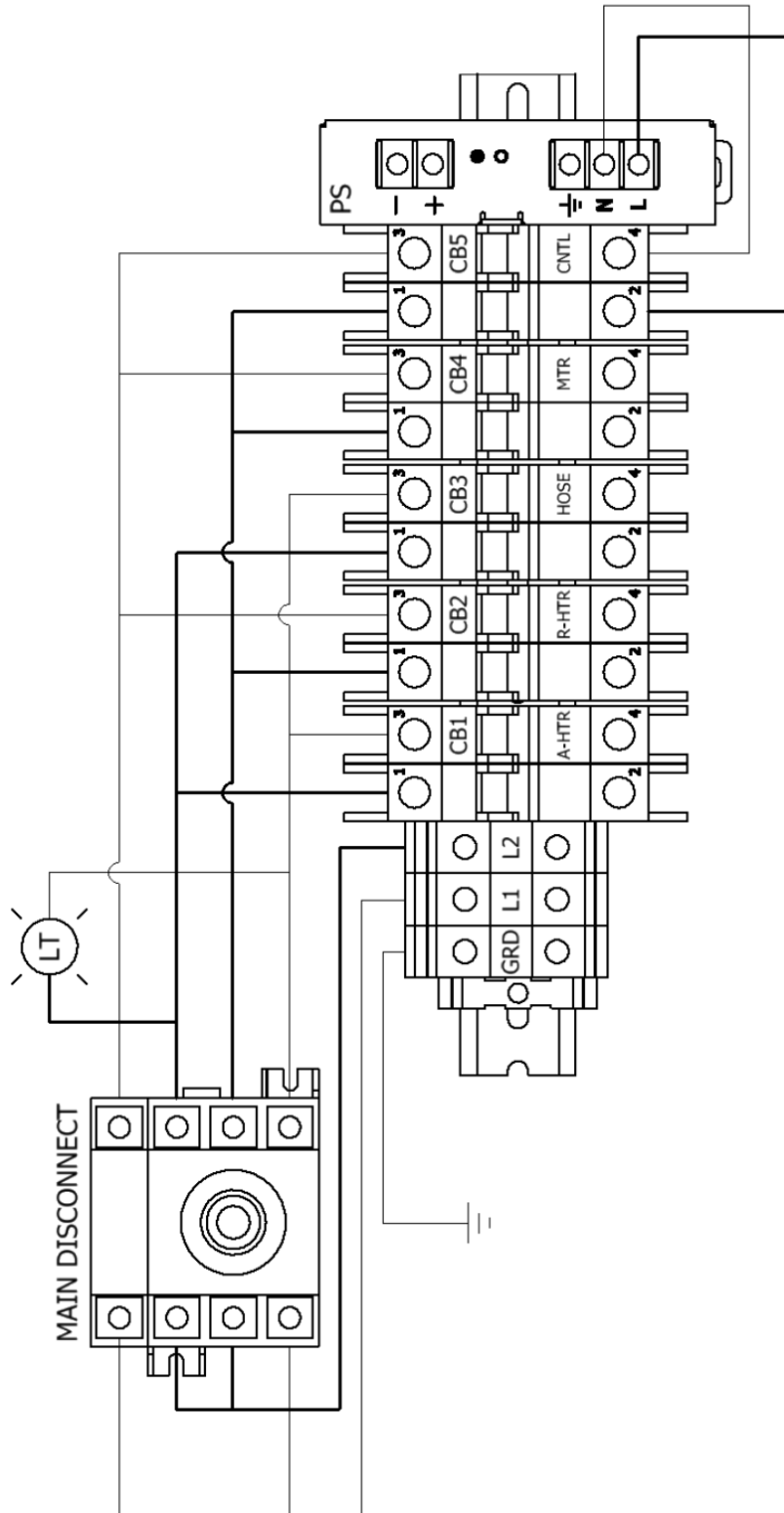

Heater Circuit

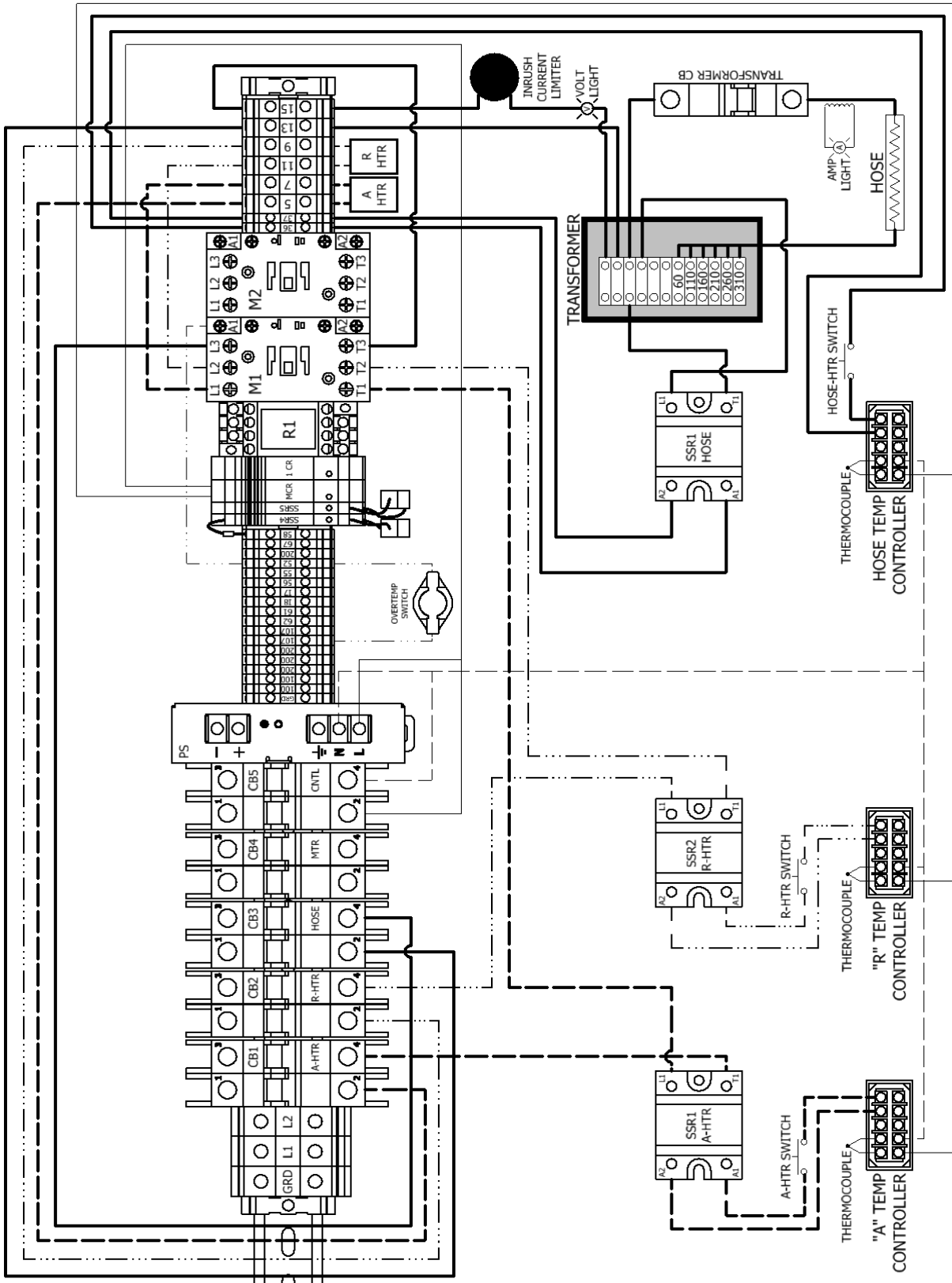

Motor Circuit

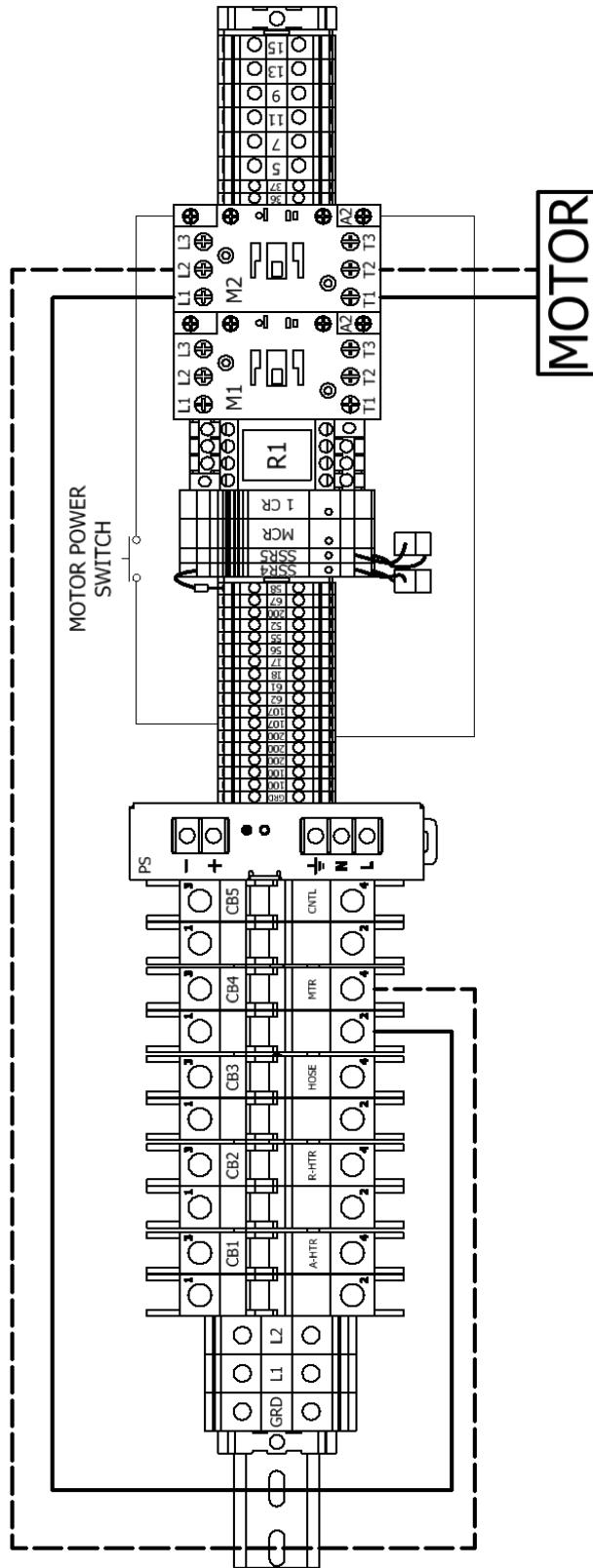

24 VDC Power Circuit

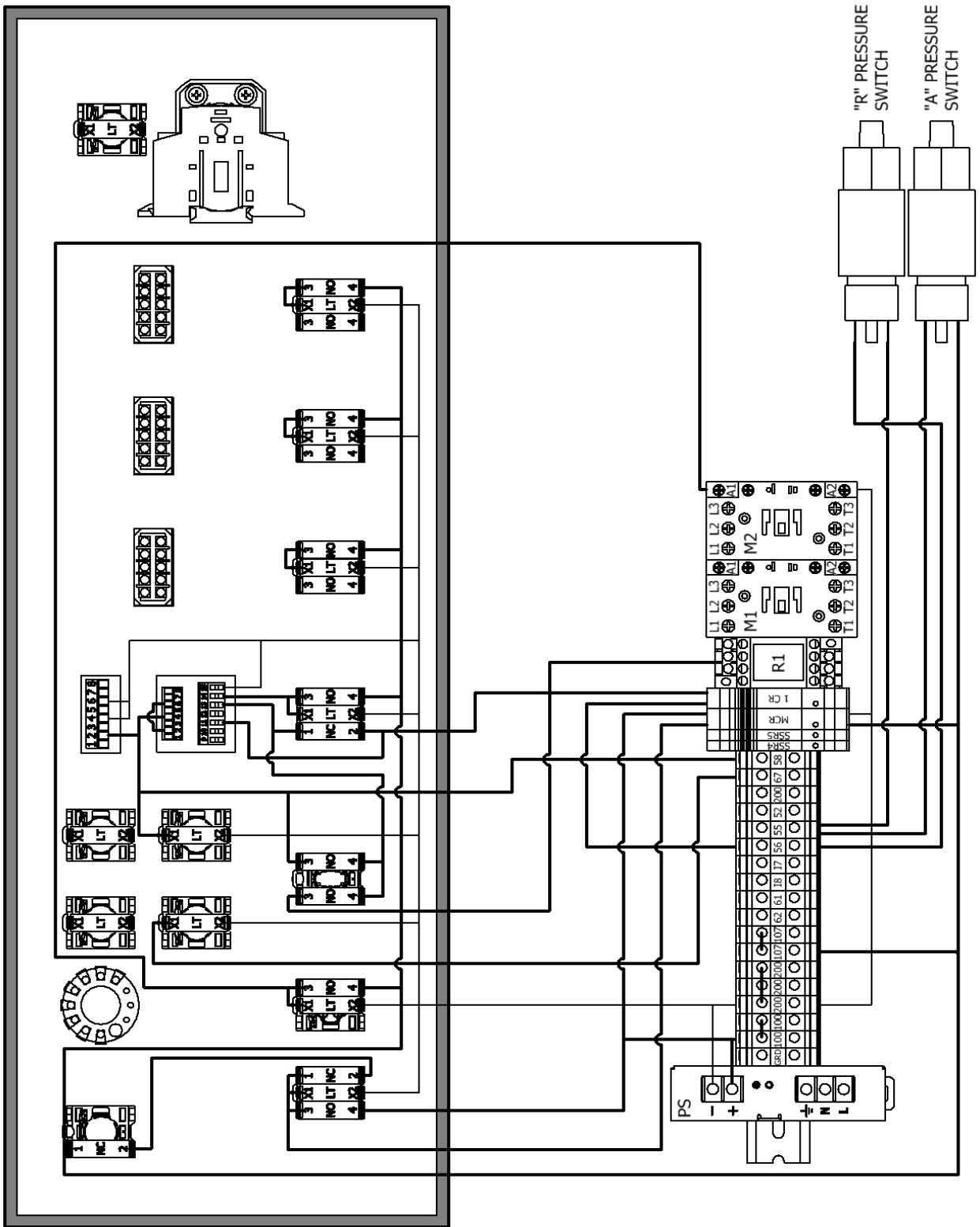

Pump Circuit

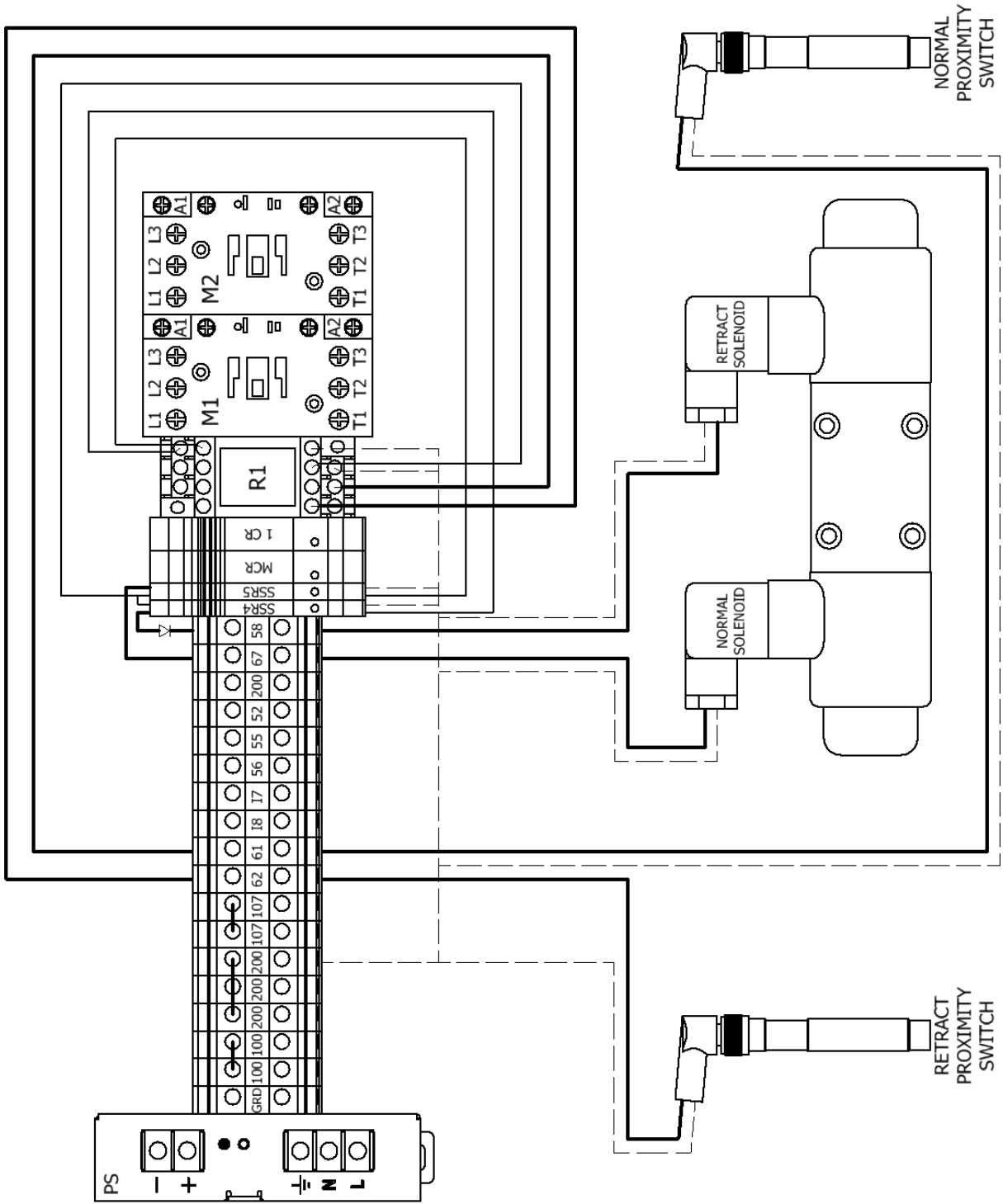

Pressure Balance Control Circuit

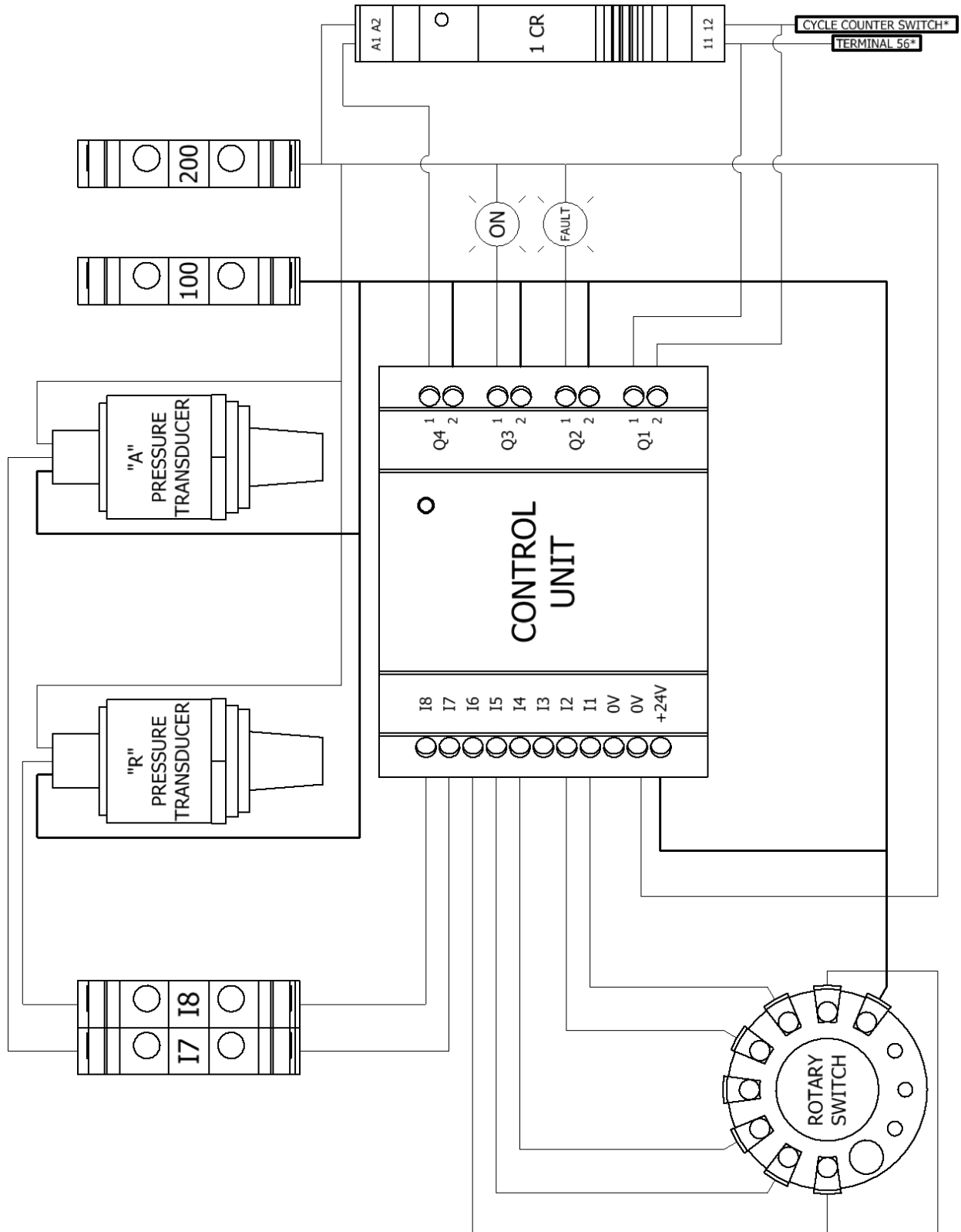

* See 24VDC Power Circuit (Pg.13)

Ladder Diagrams

Incoming Power

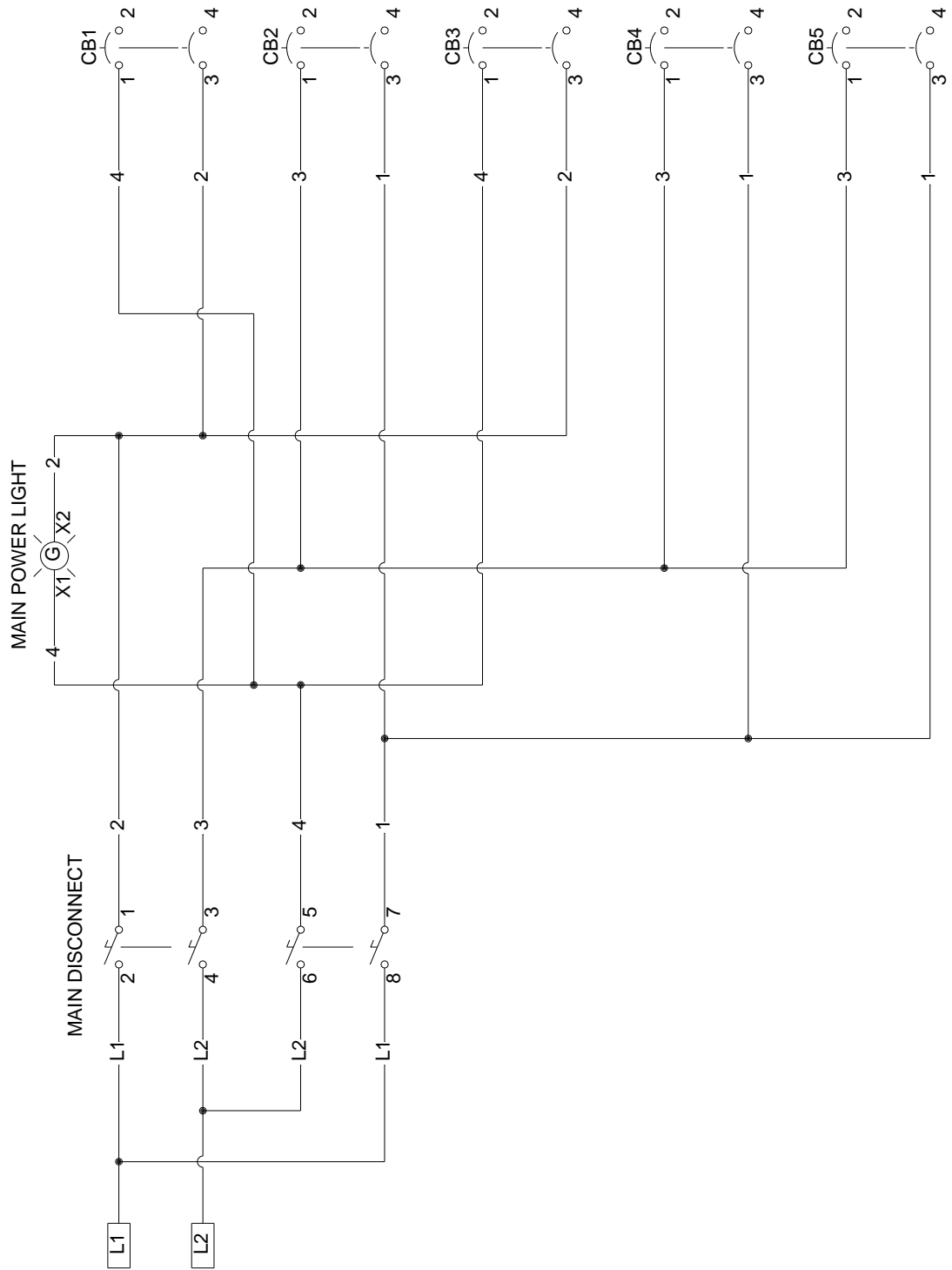

Heater Circuit

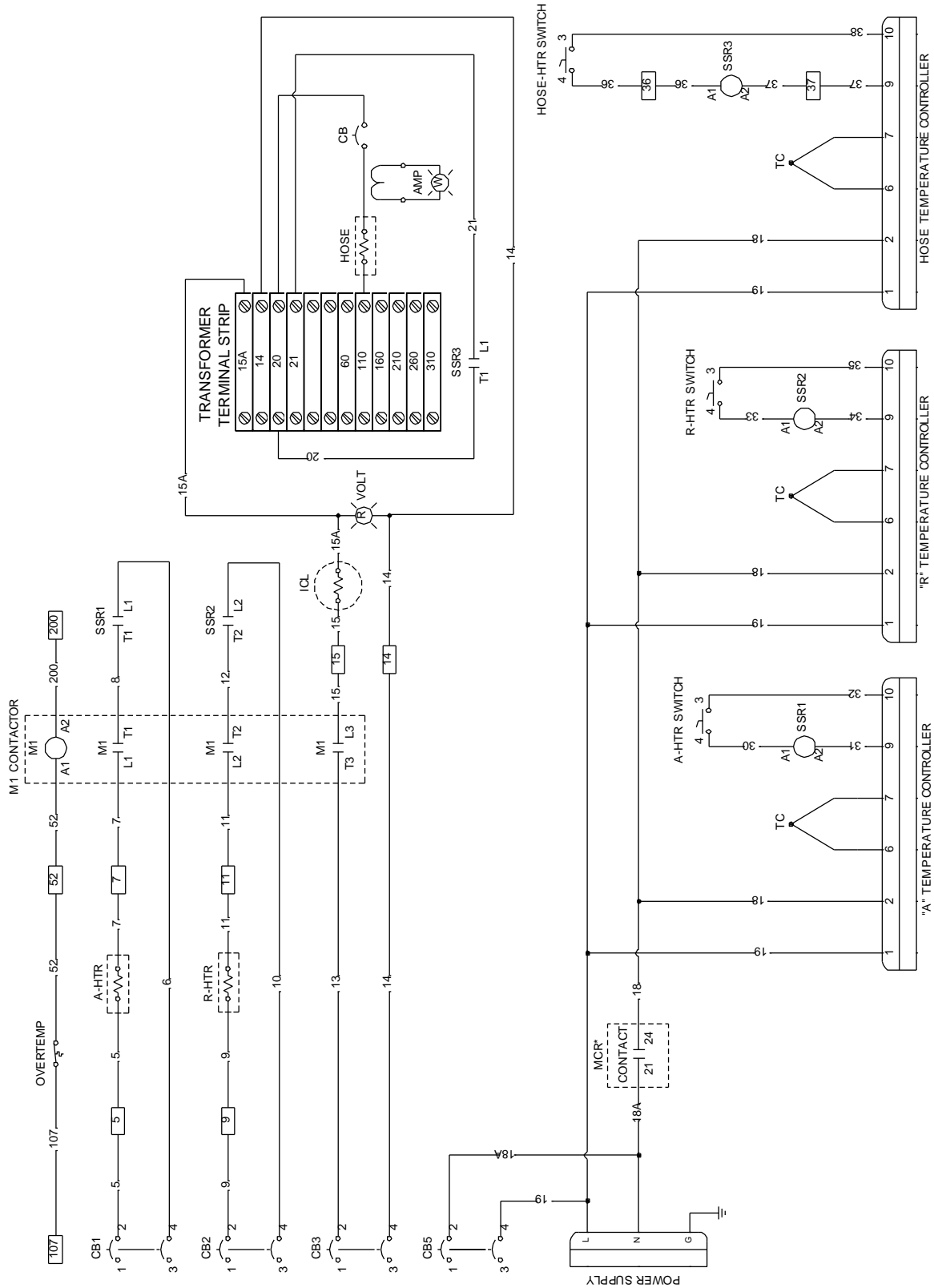

*See 24 VDC Power Circuit (Pg. 19) for complete MCR wire connections

Motor Circuit

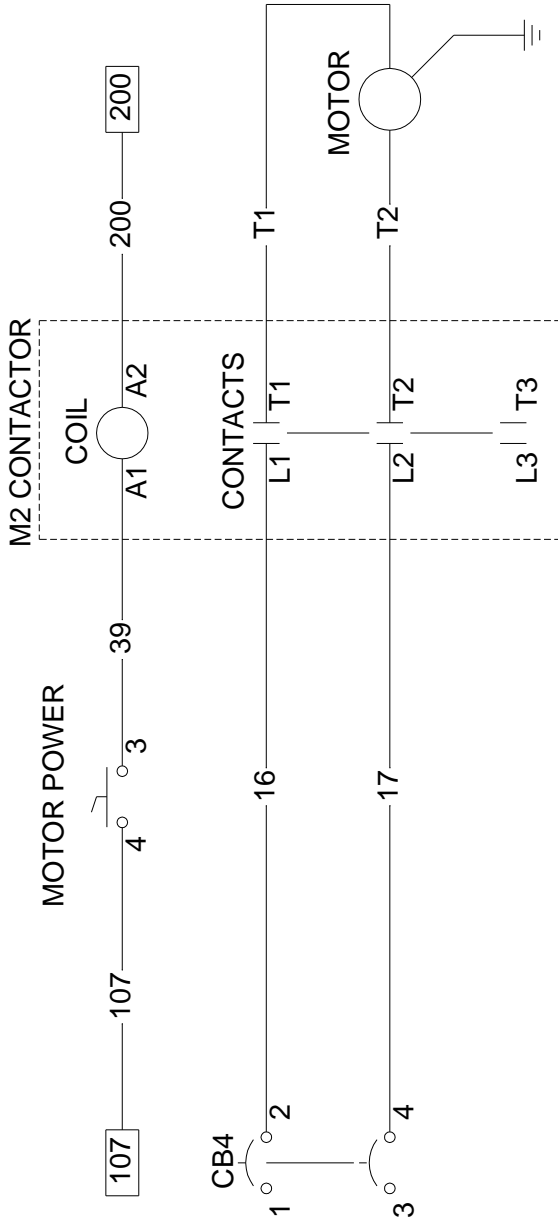

MOTOR WIRING CONFIGURATION

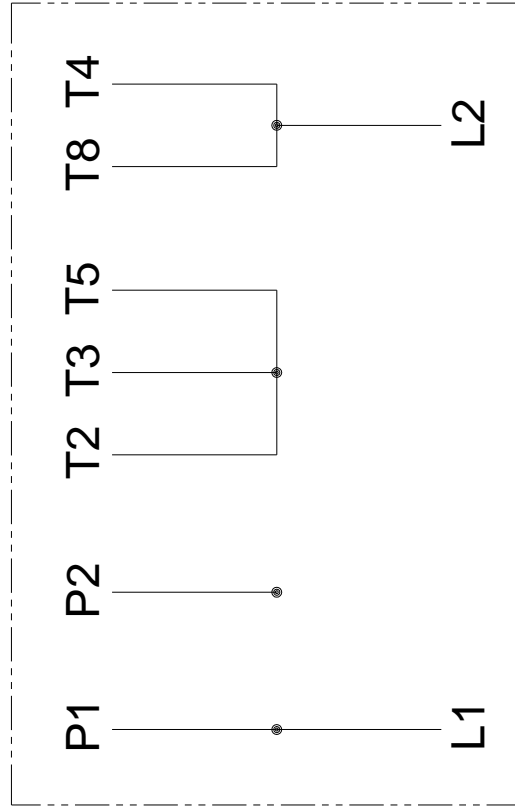

24 VDC Power Circuit

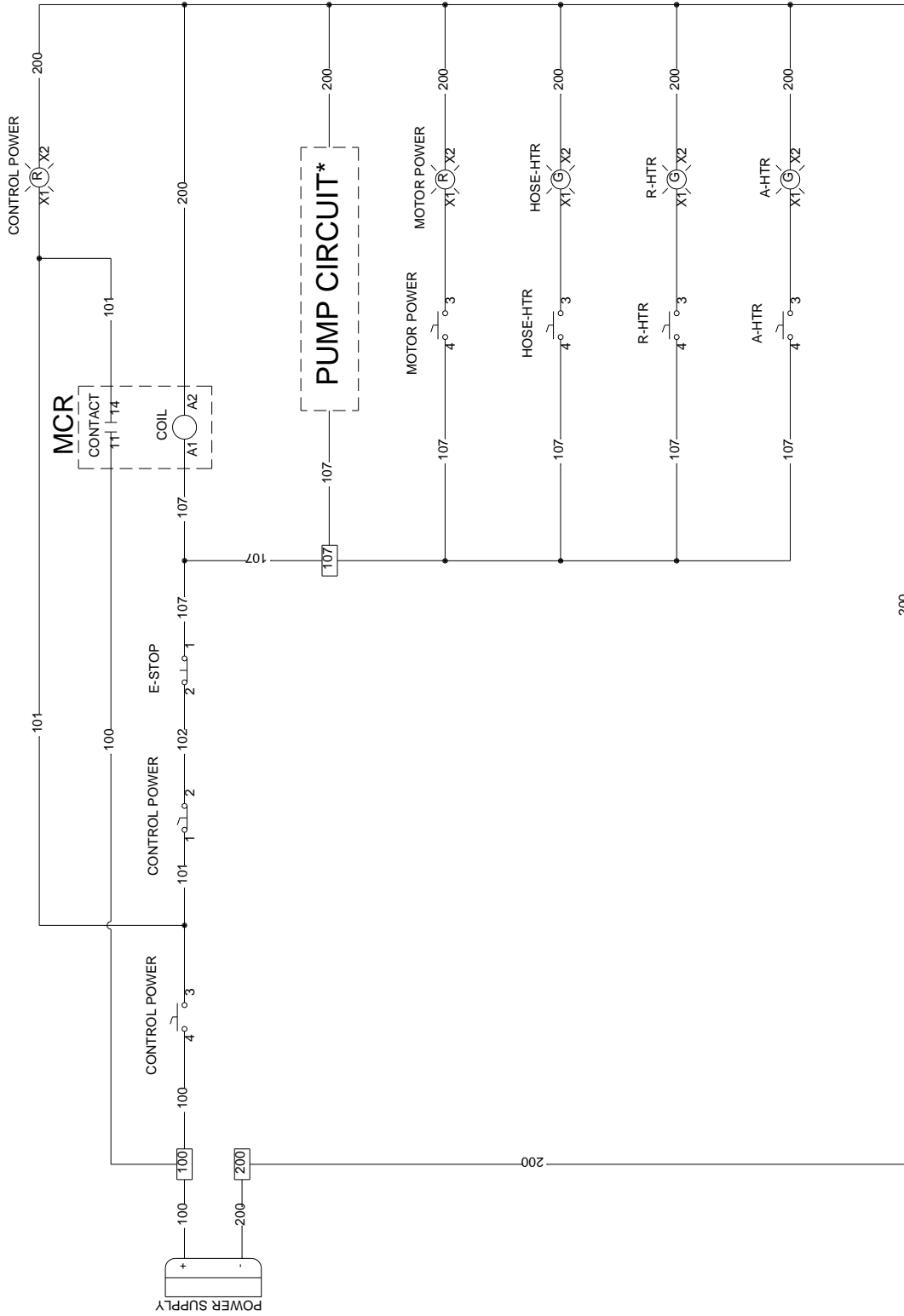

*See Pump Circuit (Pg. 20)

Pump Circuit

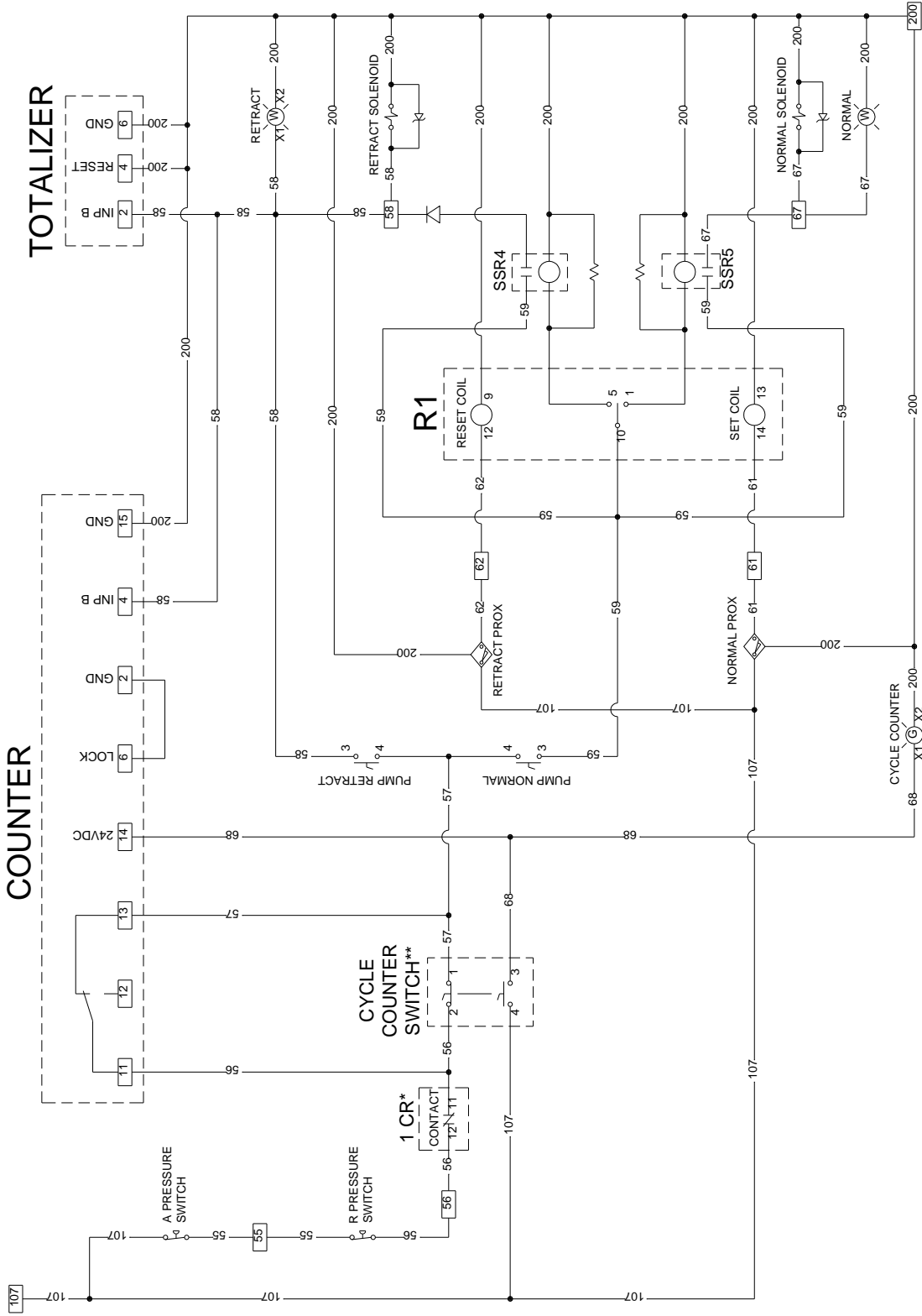

*See Pressure Balance Control Circuit (Pg. 21) for complete 1 CR wire connections

**When the cycle counter switch is turned "ON", the NC switch opens and the NO switch closes simultaneously

Pressure Balance Control Circuit

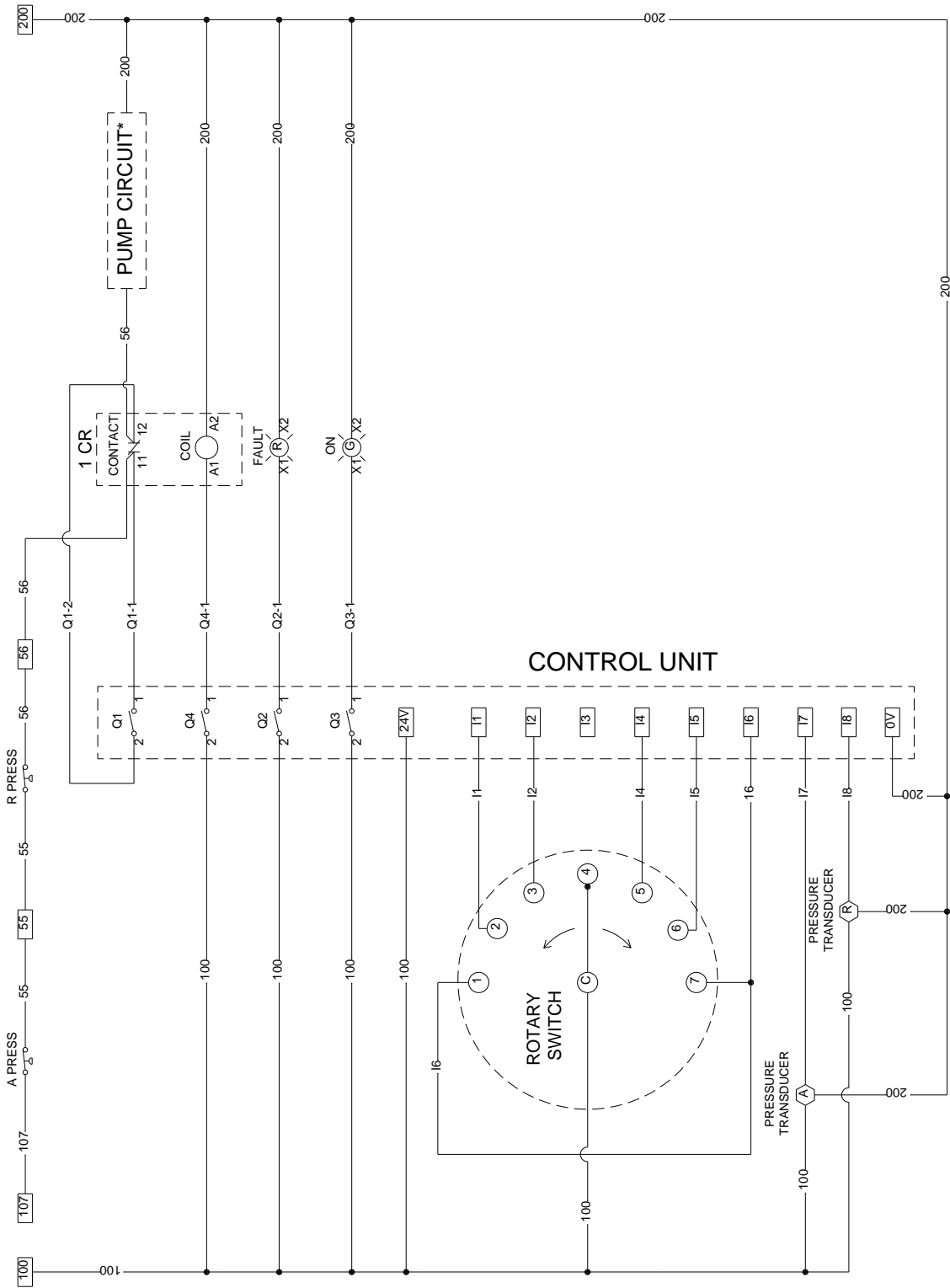

*See Pump Circuit (Pg. 20)

220 VAC – 3 Phase

Component Identification

Front Panel

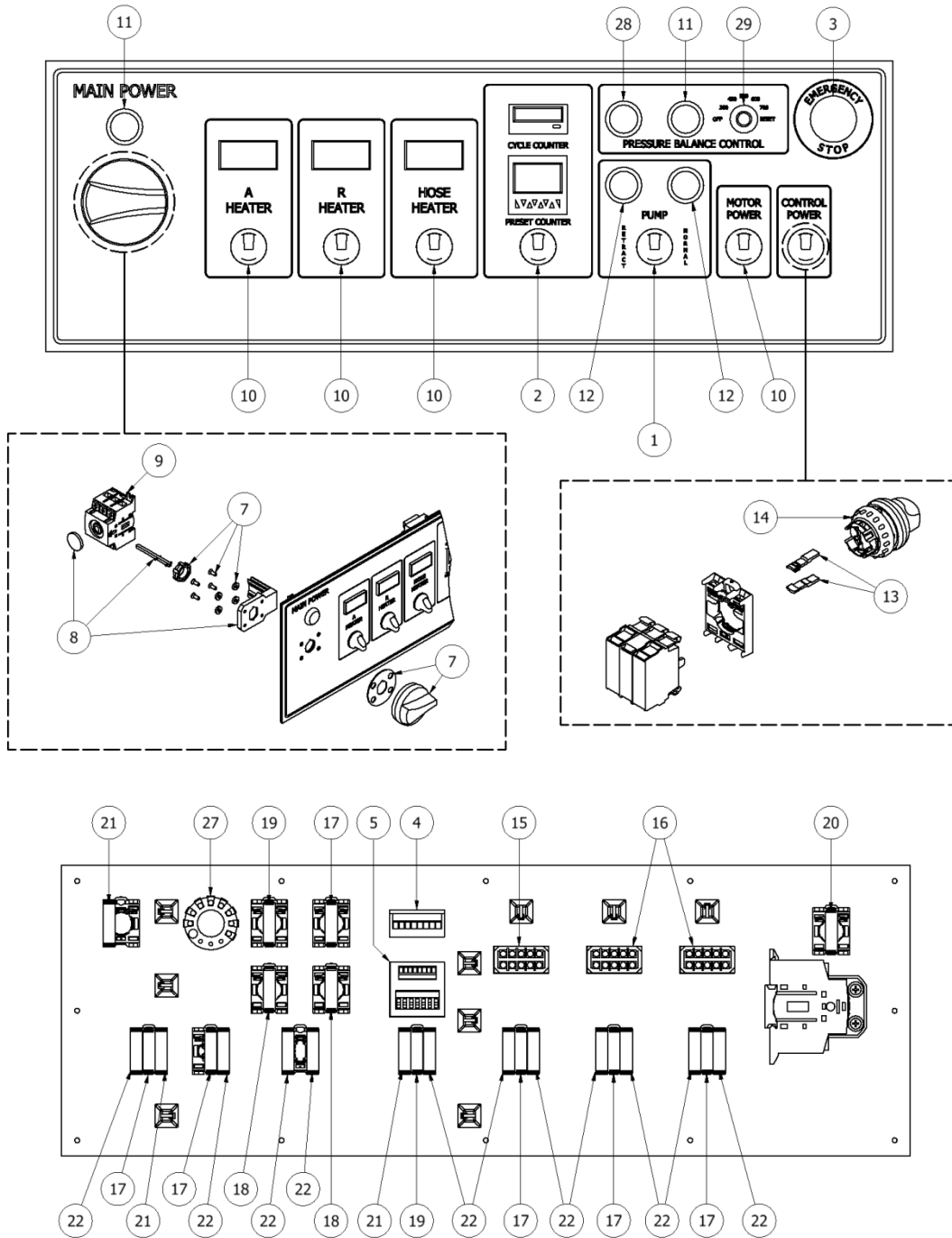

COMPONENT LIST			
ITEM	QTY	PART NUMBER	DESCRIPTION
1	1	EL-128-W	SELECTION SWITCH; 3 POS; WHT
2	1	EL-129-G	SELECTOR SWITCH; GREEN
3	1	EL-107	E-STOP PUSH TWIST
4	1	EL-124	TOTALIZER; BATT OP
5	1	EL-127	COUNTER
7	1	EL-105	SELECTOR HANDLE; RED
8	1	EL-103	DOOR MOUNTING KIT
9	1	EL-100	ROTARY DISCONNECT; 80A; 3 POLE
10	4	EL-129-R	SELECTOR SWITCH; RED
11	2	EL-134	LIGHT HOUSING
		EL-135	GREEN LENS; "ON"
12	2	EL-134	LIGHT SWITCH
		EL-138	AMBER LENS; LEFT ARROW
13	1	EL-130	CODING ADAPTER
14	1	EL-128-R	SELECTOR SWITCH; 3 POS; RED
15	1	EL-T2	TEMPERATURE CONTROLLER; HOSE
16	2	EL-T1	TEMPERATURE CONTROLLER; PRE-HTR
17	6	EL-131-R	LIGHT UNIT; RED; 24VDC
18	2	EL-131-W	LIGHT UNIT; WHITE 24VDC
19	2	EL-131-G	LIGHT UNIT; GRN; 24VDC
20	1	EL-132-G	GREEN LIGHT UNIT
21	3	EL-133-NC	CONTACT BLOCK; NC
22	11	EL-133-NO	CONTACT BLOCK; NO
27	1	EL-196	ROTARY SWITCH 7 POS
28	1	EL-134	LIGHT HOUSING
		EL-137-F	RED LENS; "FAULT"
29	1	EL-197	ROTARY SWITCH KNOB

Bottom Plate

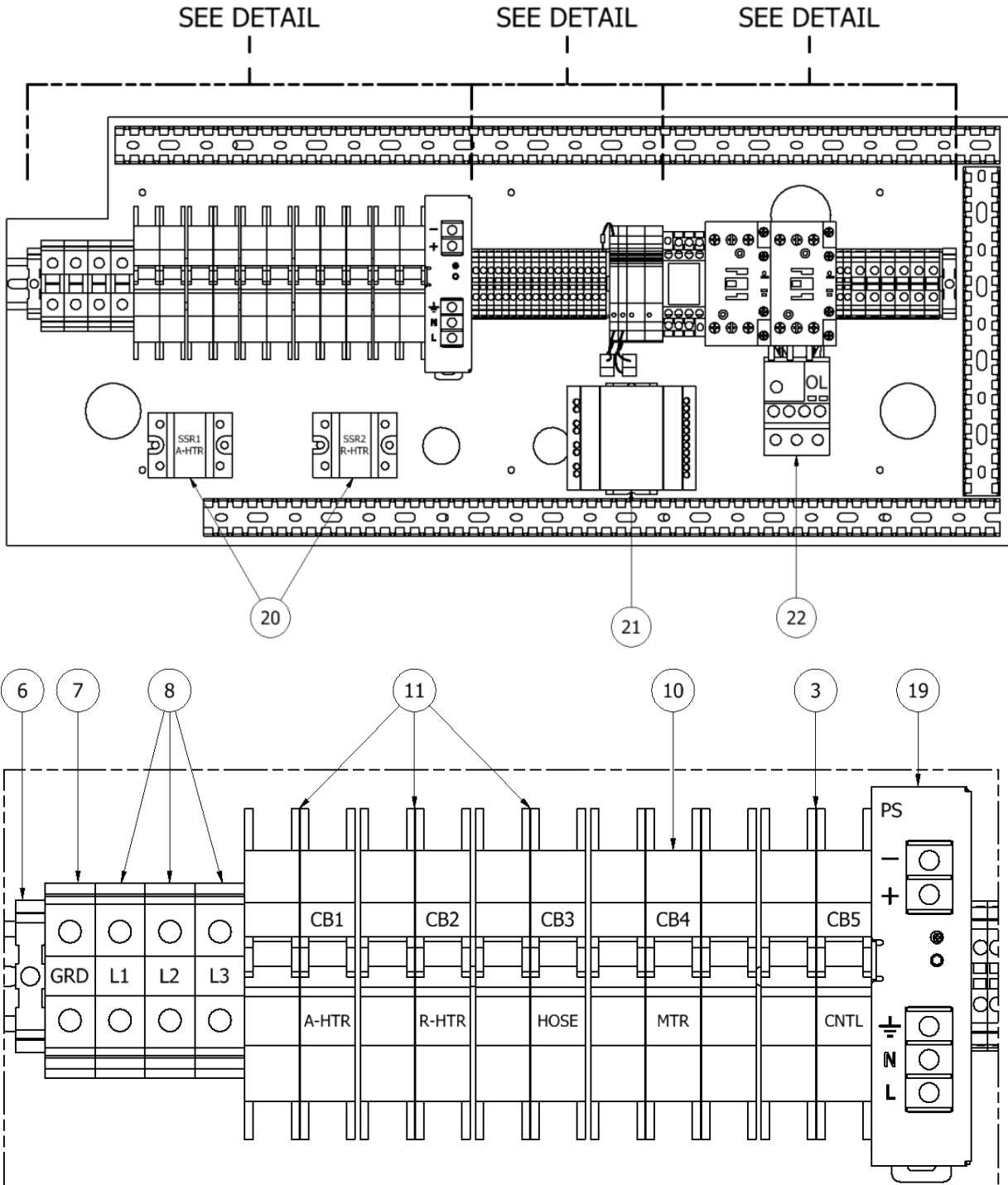

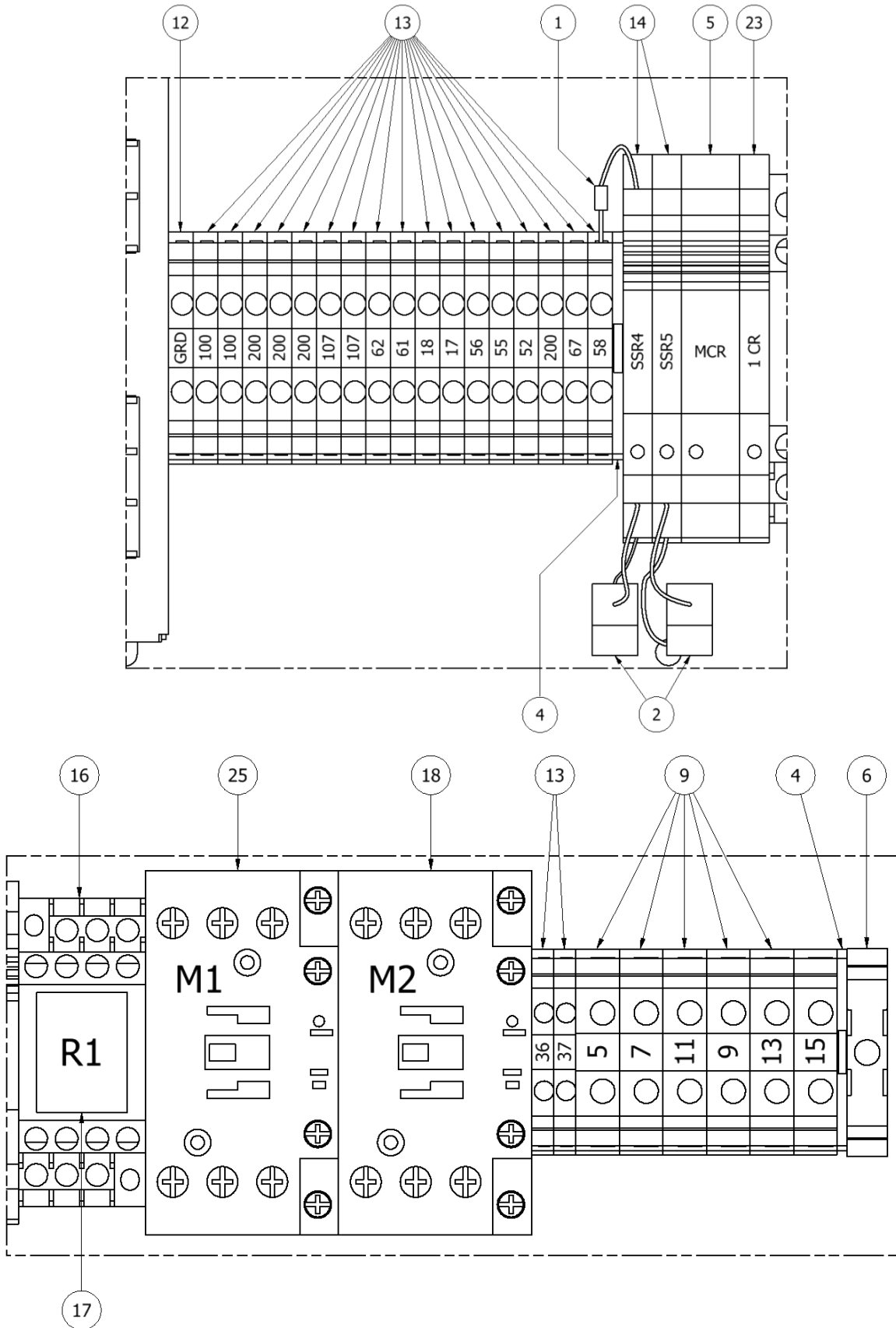

COMPONENT LIST			
ITEM	QTY	PART NUMBER	DESCRIPTION
1	1	EL-171	DIODE RECTIFIER; 1000V; 1A
2	2	EL-172	RESISTOR; 220 OHM; 5%; 3W; MET
3	1	EL-114	CIRCUIT BREAKER; 3A; 2 POLE; TYP
4	2	EL-156-10	TERMINAL COVER 10MM/5.2MM
5	1	EL-174	SS RELAY; 24 VDC
6	2	EL-152	END STOP; 35MM
7	1	EL-146	TERMINAL BLOCK; 16MM; GROUND
8	3	EL-143	TERMINAL BLOCK; 16MM
9	6	EL-141	TERMINAL BLOCK; 10.2MM
10	1	EL-162	CIRCUIT BREAKER; 20A; 3 POLE
11	3	EL-188	BREAKER; 32A; 2 POLE
12	1	EL-144	TERMINAL BLOCK; 5.2MM; GRND
13	19	EL-140	TERMINAL BLOCK; 5.2MM
14	2	EL-160	SS RELAY; 24VDC; 2A
15	1	EL-119	CONTACTOR; 25A; 24VDC COIL
16	1	EL-155	RELAY SOCKET
17	1	EL-154	LATCHING RELAY; 24VDC
18	1	EL-118	CONTACTOR; 32A; 24VDC COIL (FOR 120V TRANSFORMER)
	1	EL-119	CONTACTOR; 25A; 24VDC COIL (FOR 90V & 70V TRANSFORMER)
19	1	EL-122	POWER SUPPLY; 2.5A; 230VAC/24VDC
20	2	EL-34	RELAY; 50 AMP; 480V
21	1	EL-194-1	BAL CONT UNIT
22	1	EL-161	40-20A
23	1	EL-198	RELAY, SPDT, 24 VDDC
25	1	EL-125	CONTACTOR; 40A; 24VDC

Point to Point Diagrams

Incoming Power

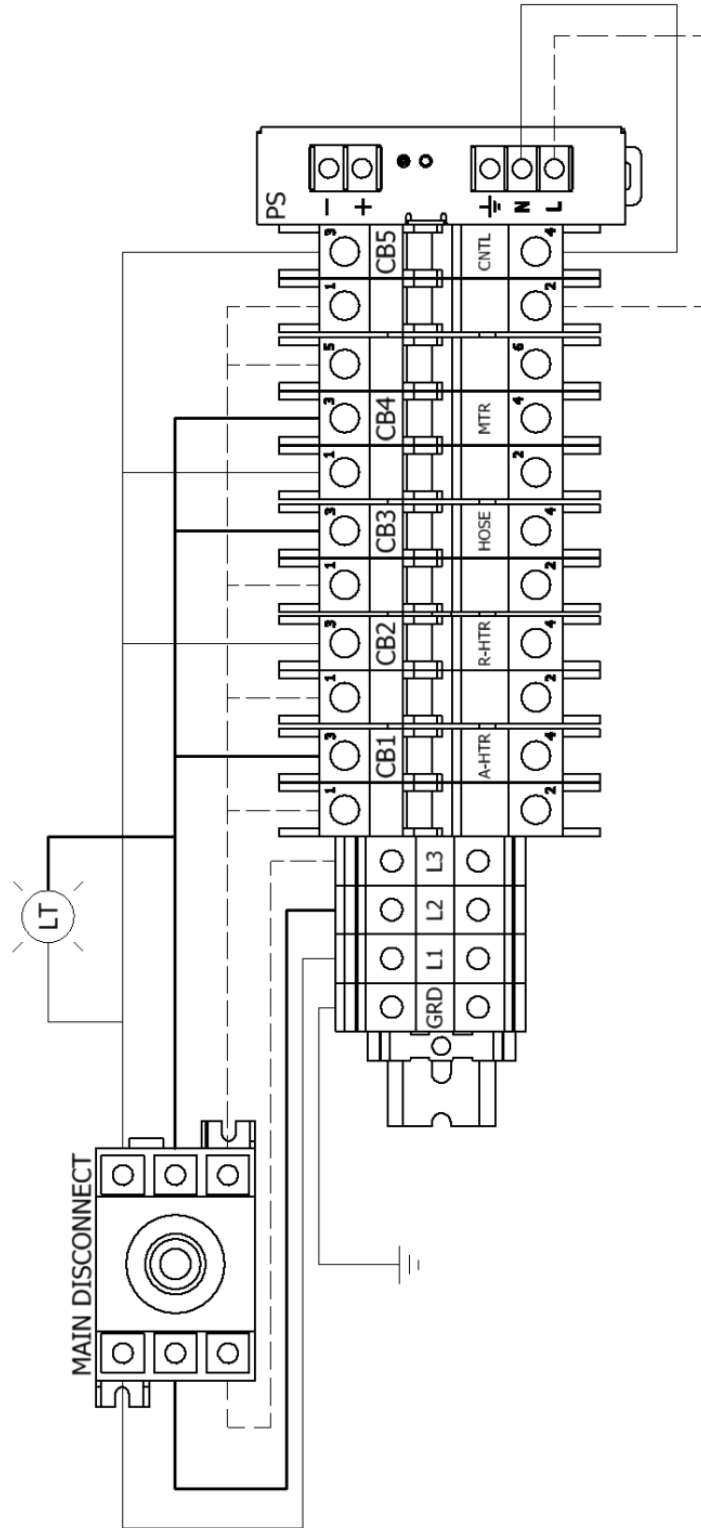

Heater Circuit

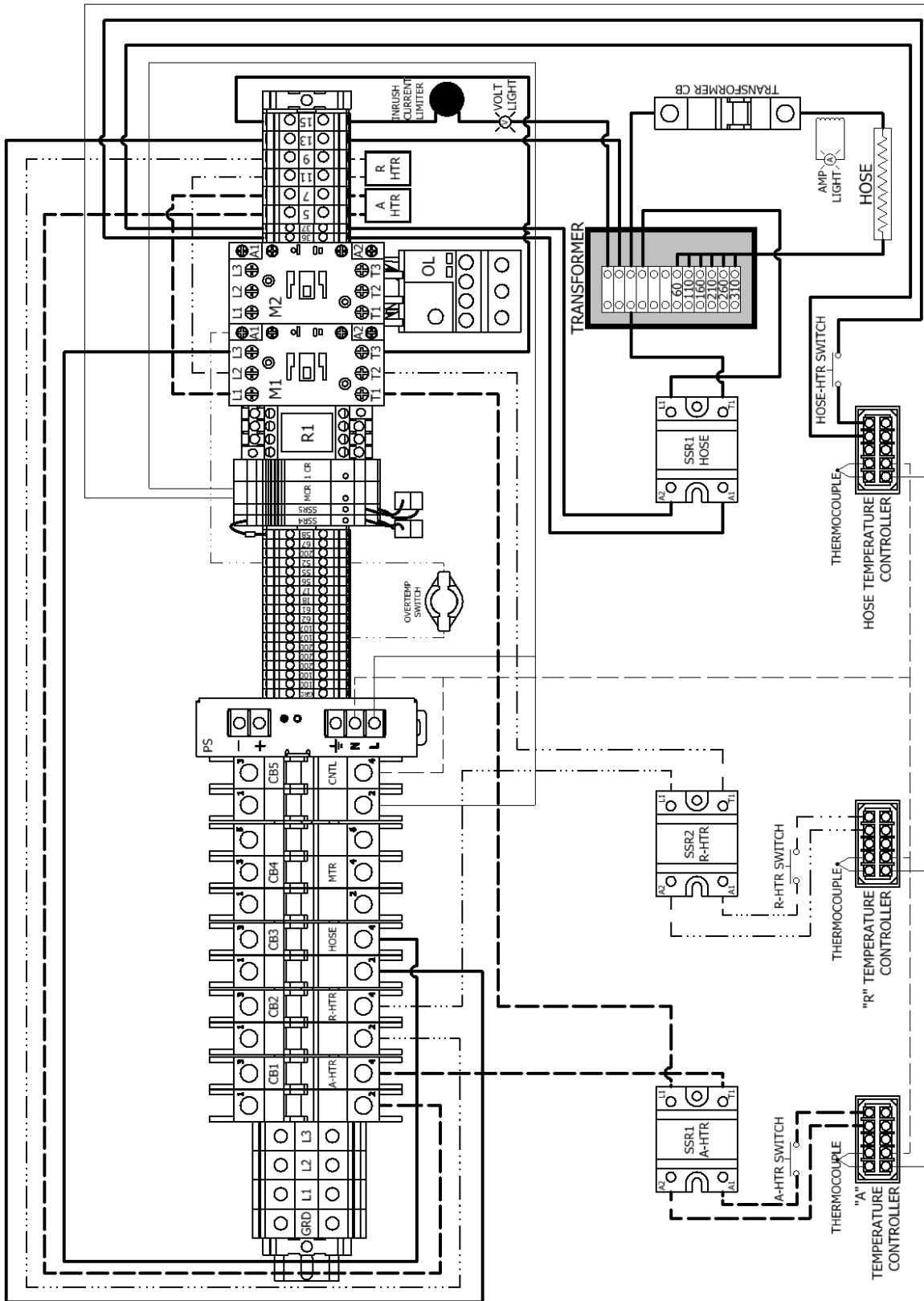

Motor Circuit

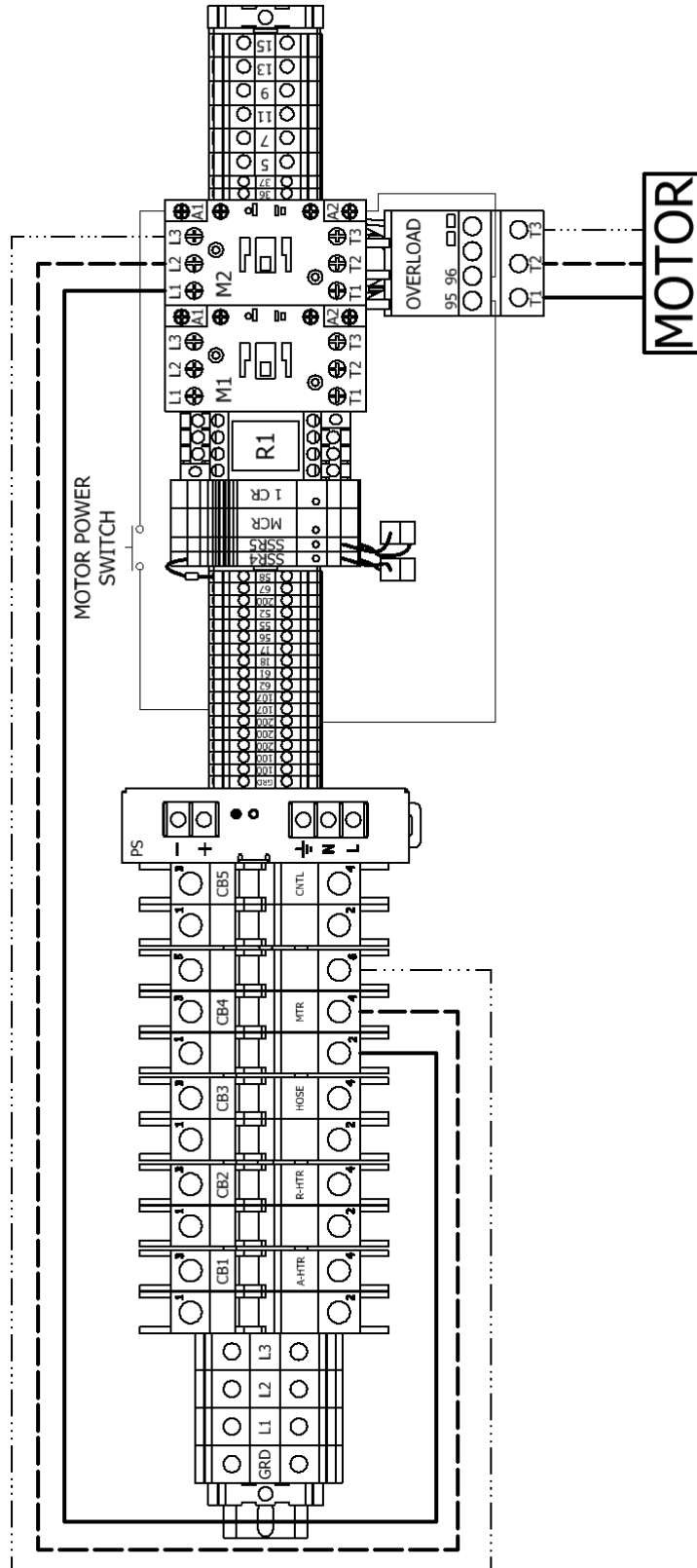

24 VDC Power Circuit

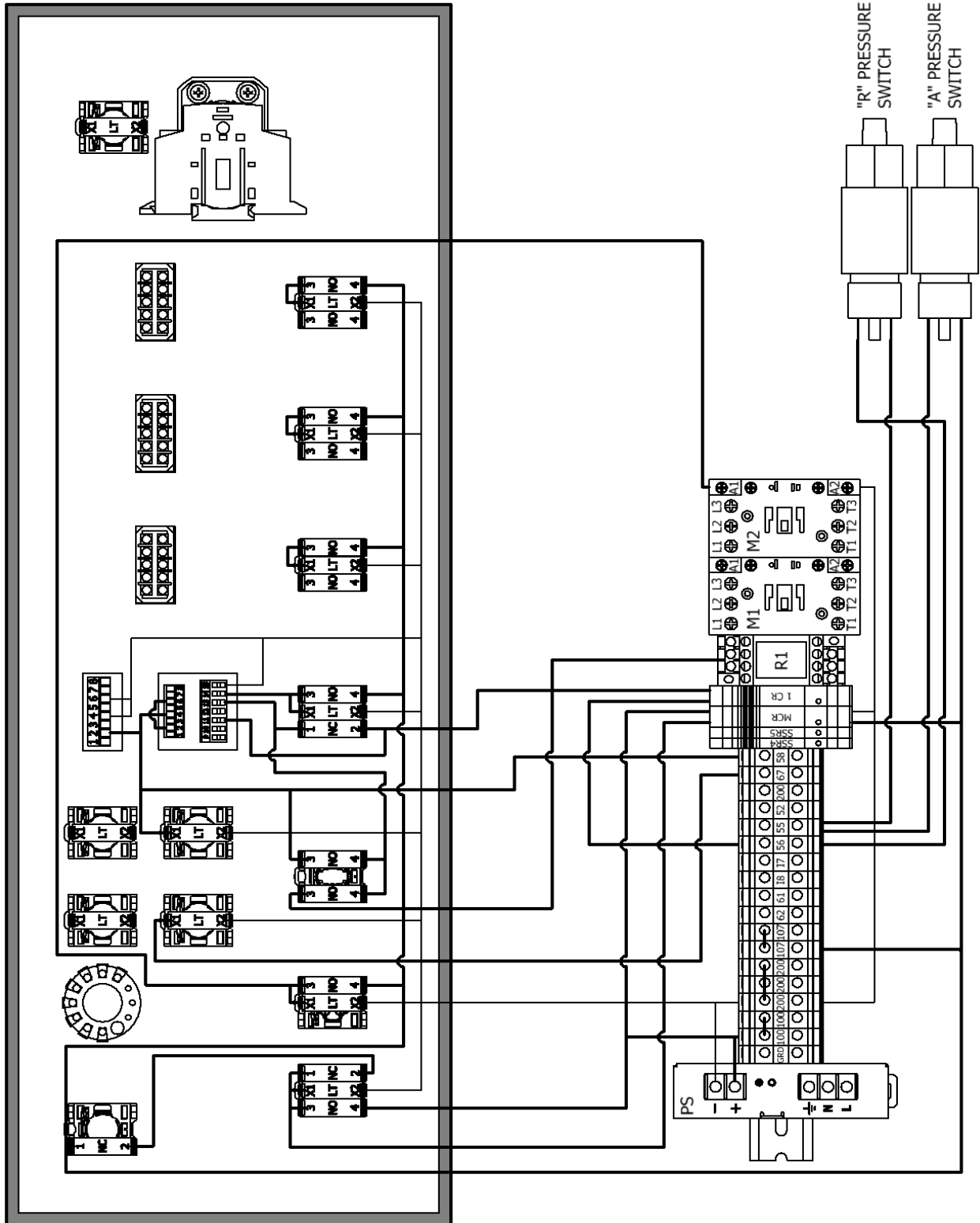

Pump Circuit

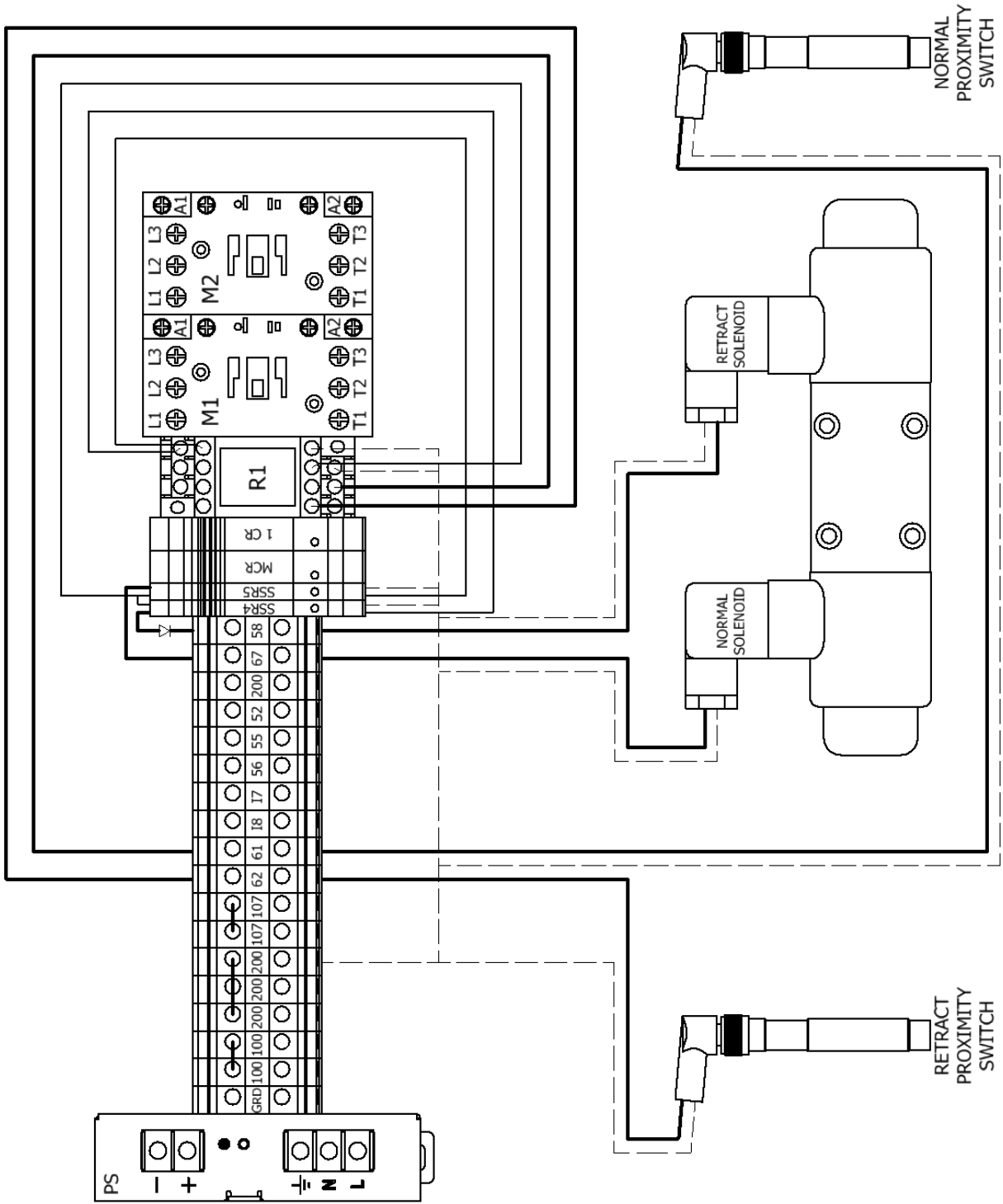

Pressure Balance Control Circuit

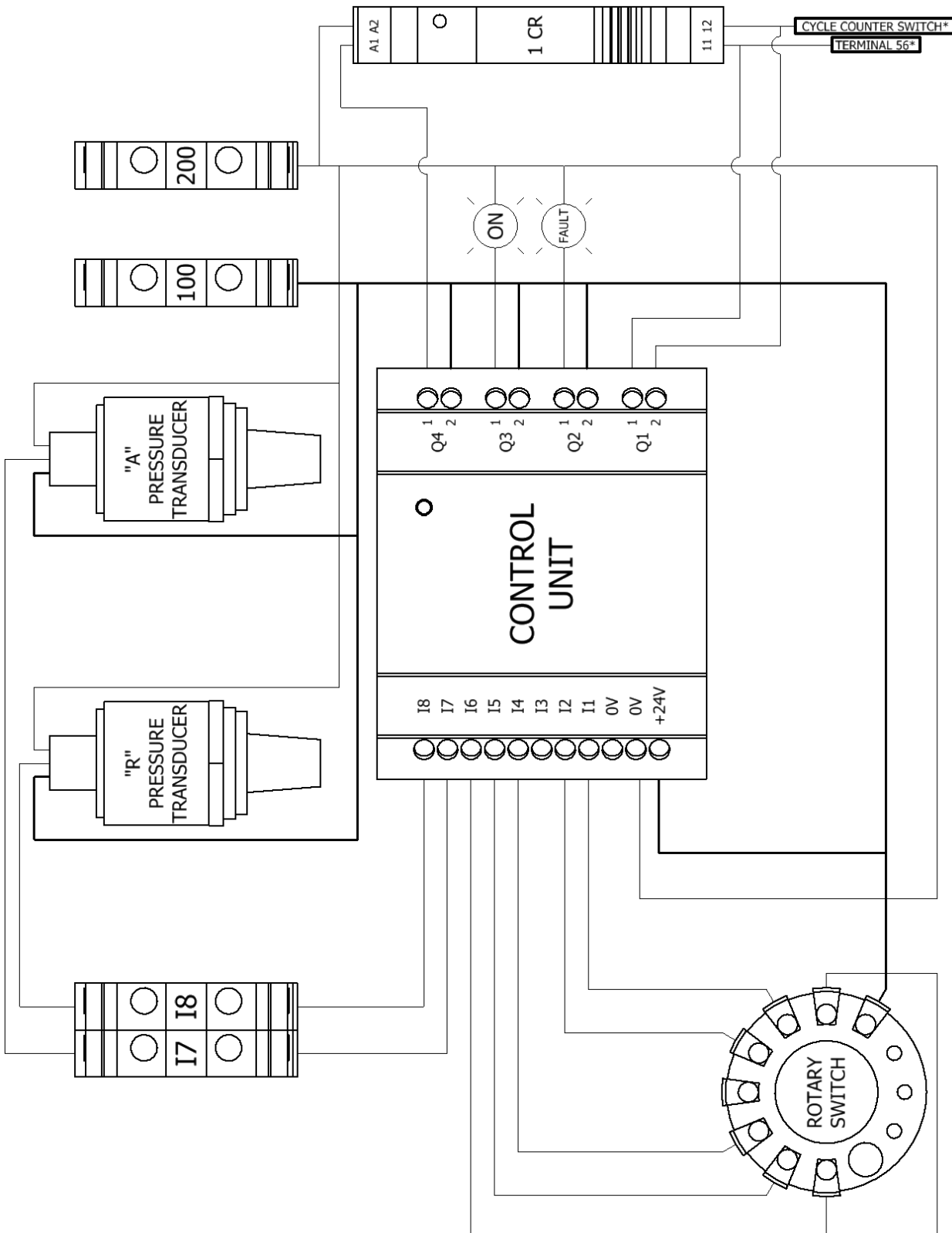

*See 24 VDC Power Circuit (Pg. 30)

Ladder Diagrams

Incoming Power

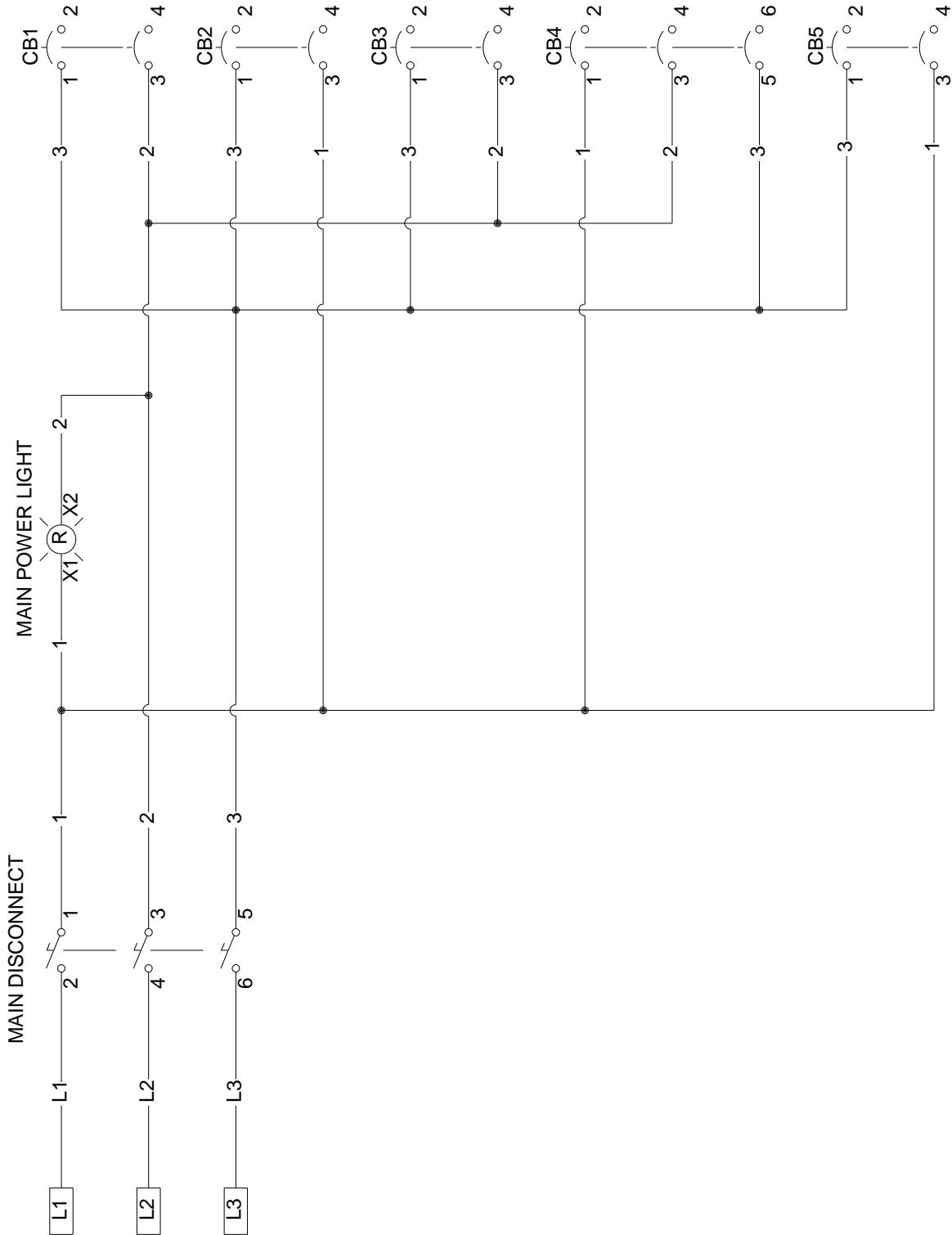

Heater Circuit

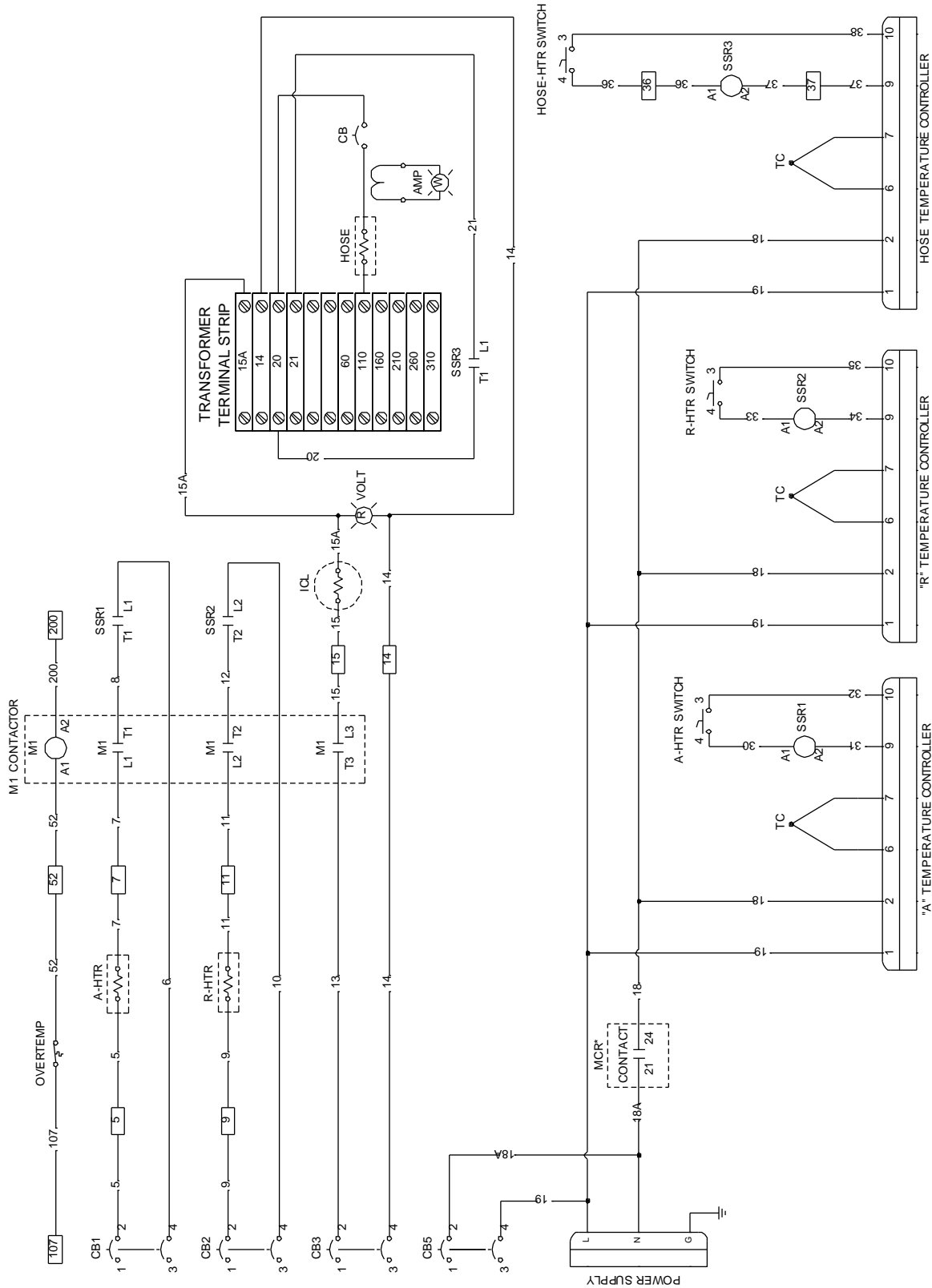

*See 24 VDC Power Circuit (Pg. 36) for complete MCR wire connections

Motor Circuit

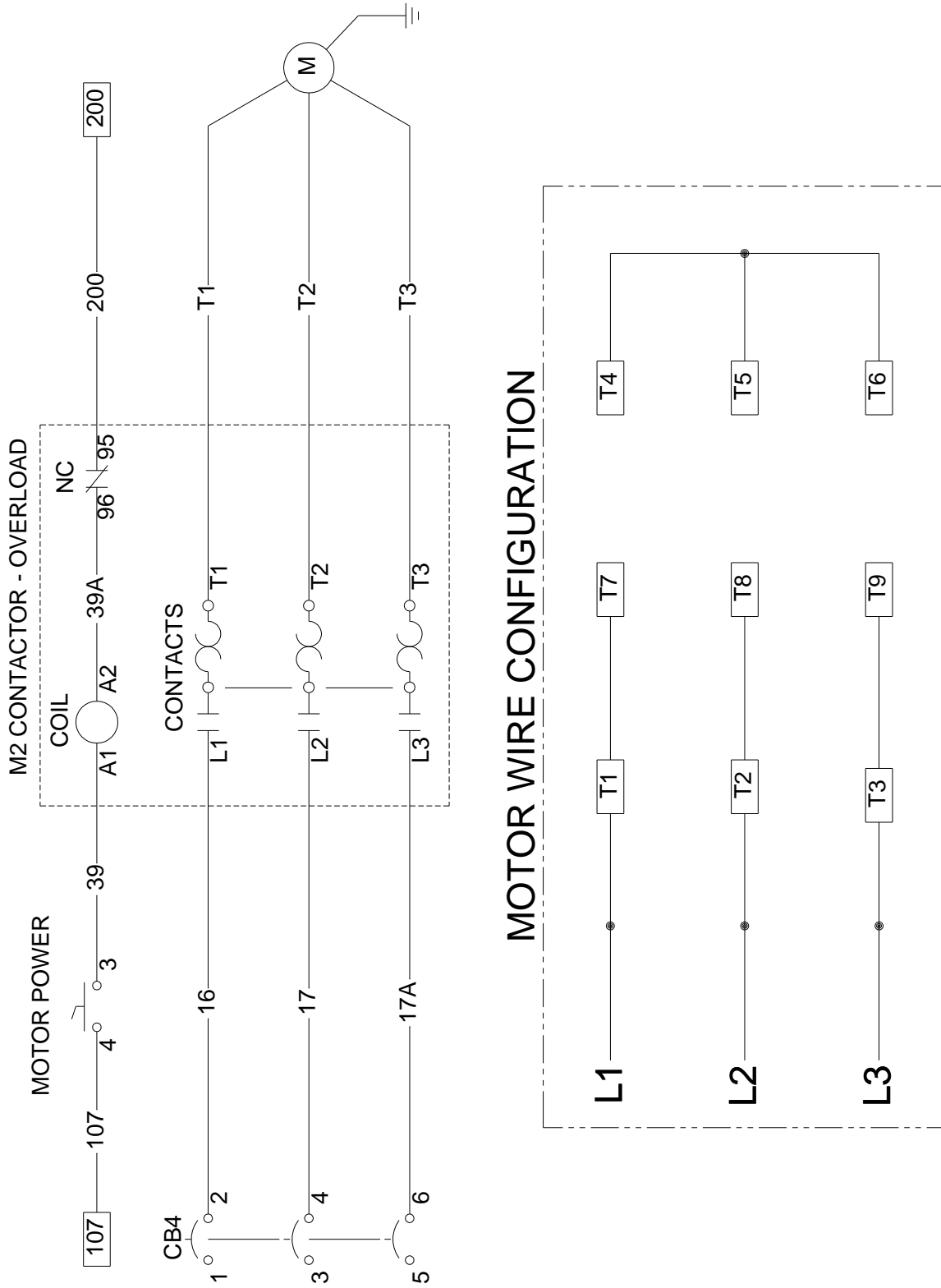

24 VDC Power Circuit

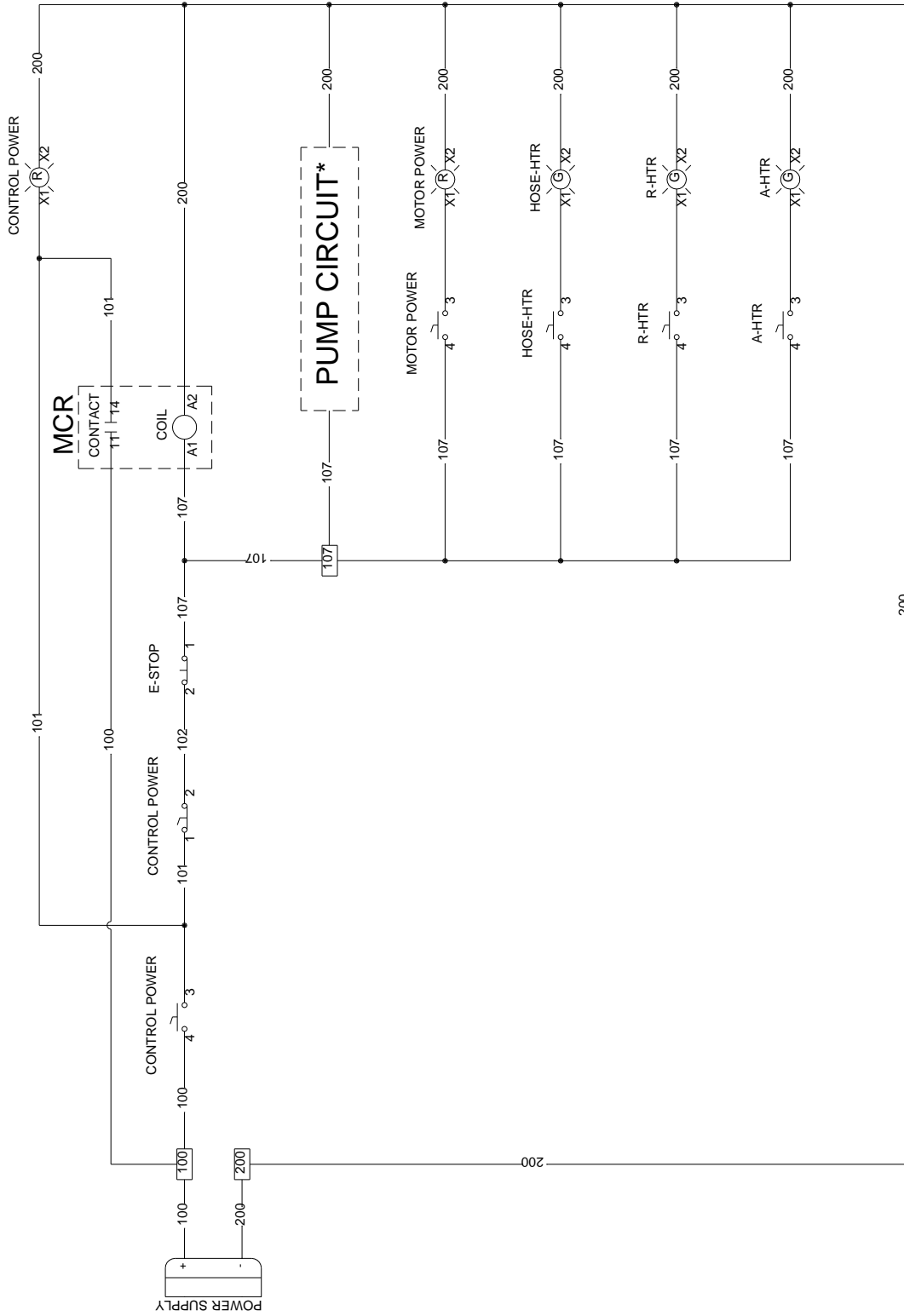

*See Pump Circuit (Pg. 37)

Pump Circuit

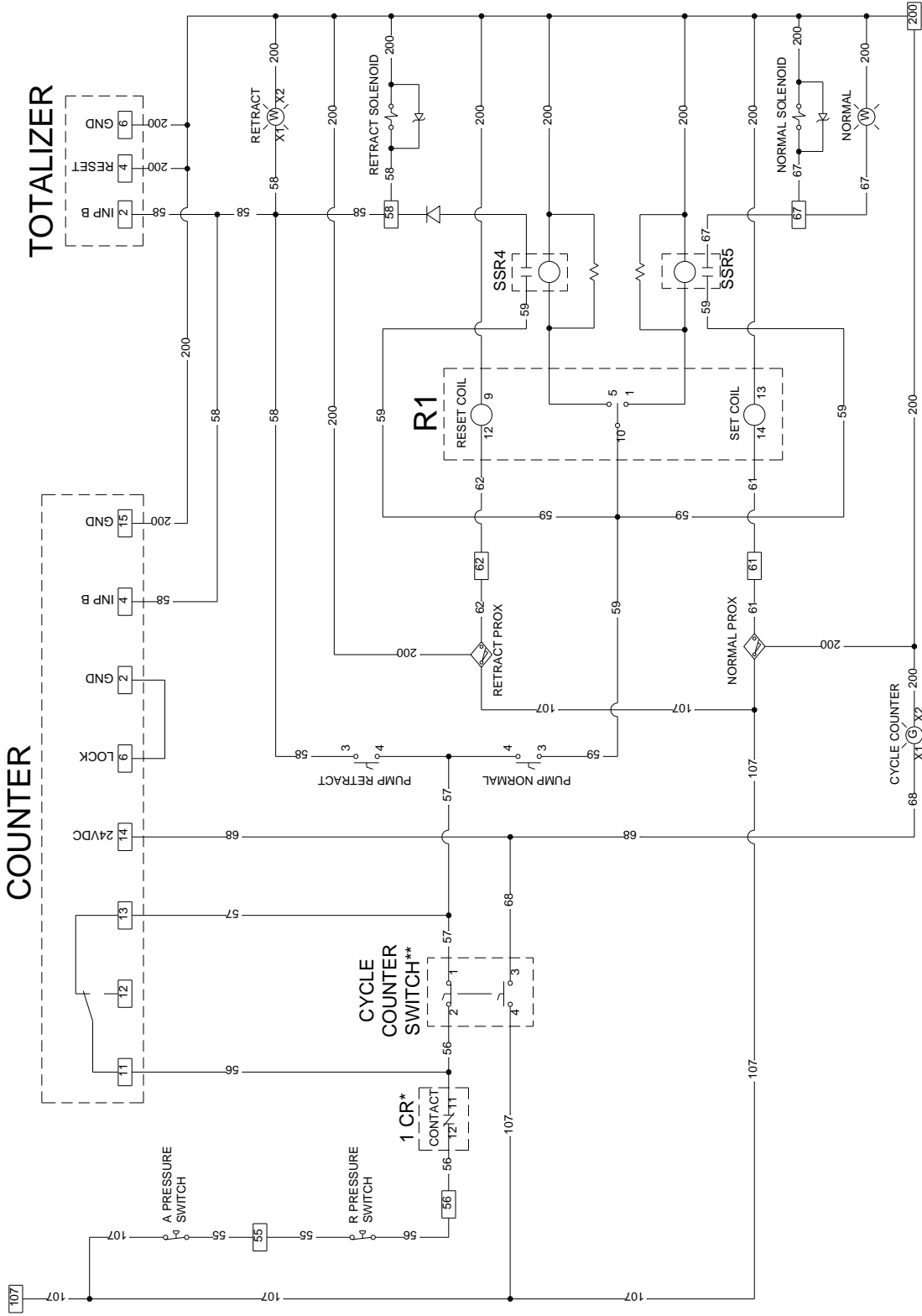

*See Pressure Balance Control Circuit (Pg. 38) for complete 1 CR wire connections

**When the cycle counter switch is turned "ON", the NC switch opens and the NO switch closes simultaneously

Pressure Balance Control Circuit

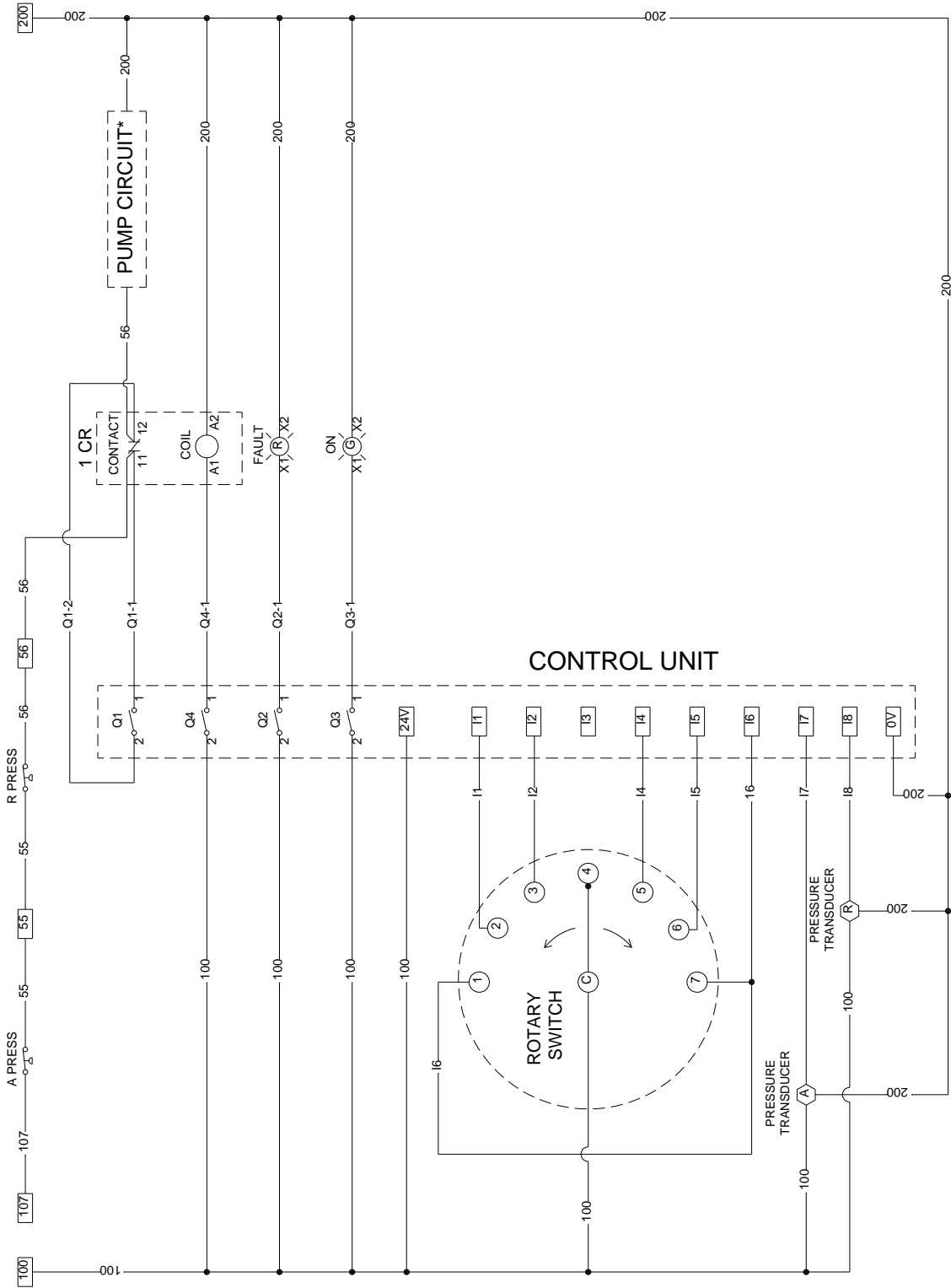

*See Pump Circuit (Pg. 37)

380 VAC

Component Identification

Front Panel

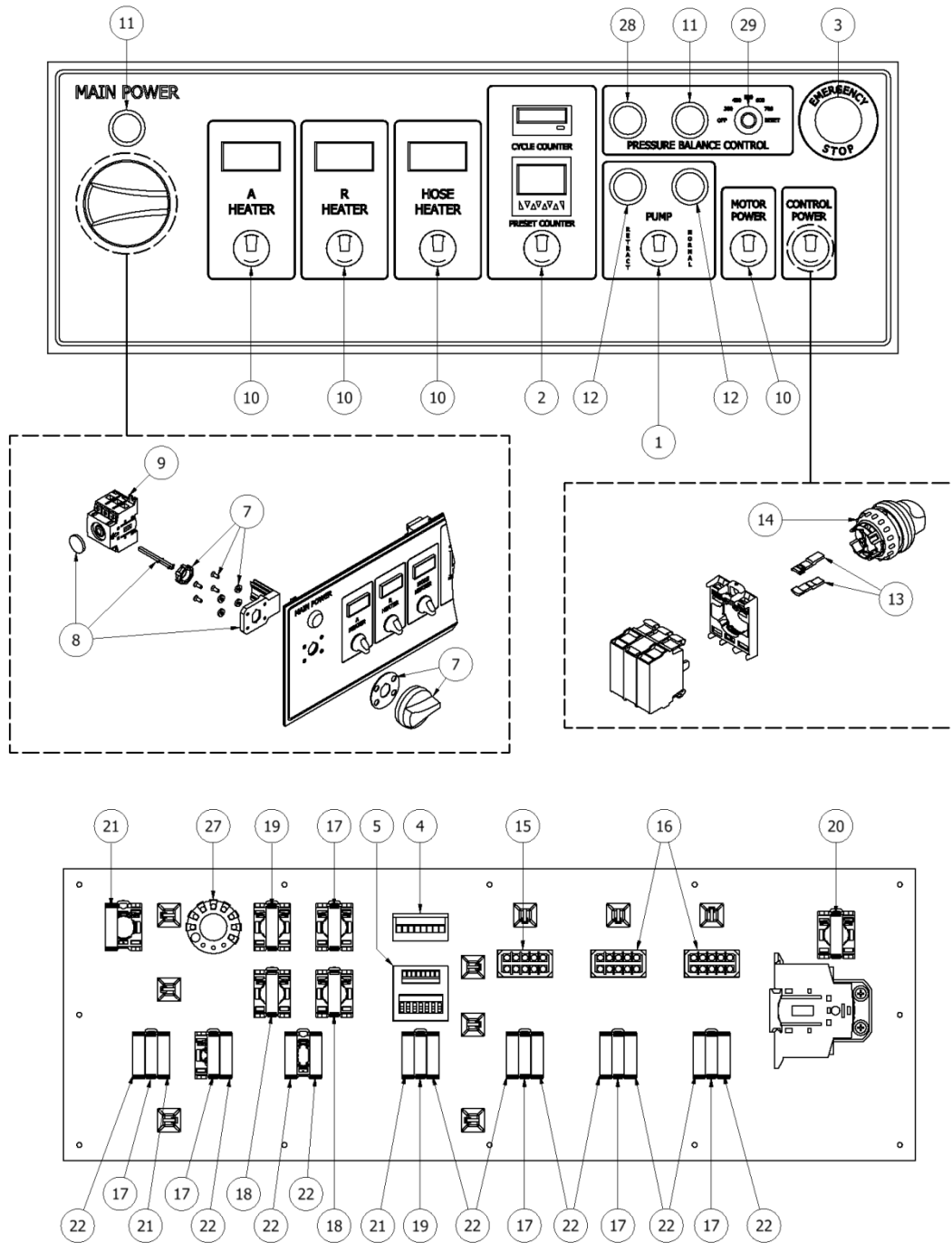

COMPONENT LIST			
ITEM	QTY	PART NUMBER	DESCRIPTION
1	1	EL-128-W	SELECTION SWITCH; 3 POS; WHT
2	1	EL-129-G	SELECTOR SWITCH; GREEN
3	1	EL-107	E-STOP PUSH TWIST
4	1	EL-124	TOTALIZER; BATT OP
5	1	EL-127	COUNTER
7	1	EL-105	SELECTOR HANDLE; RED
8	1	EL-103	DOOR MOUNTING KIT
9	1	EL-100	ROTARY DISCONNECT; 80A; 3 POLE
10	4	EL-129-R	SELECTOR SWITCH; RED
11	2	EL-134	LIGHT HOUSING
		EL-135	GREEN LENS; "ON"
12	2	EL-134	LIGHT SWITCH
		EL-138	AMBER LENS; LEFT ARROW
13	1	EL-130	CODING ADAPTER
14	1	EL-128-R	SELECTOR SWITCH; 3 POS; RED
15	1	EL-T2	TEMPERATURE CONTROLLER; HOSE
16	2	EL-T1	TEMPERATURE CONTROLLER; PRE-HTR
17	6	EL-131-R	LIGHT UNIT; RED; 24VDC
18	2	EL-131-W	LIGHT UNIT; WHITE 24VDC
19	2	EL-131-G	LIGHT UNIT; GRN; 24VDC
20	1	EL-132-G	GREEN LIGHT UNIT
21	3	EL-133-NC	CONTACT BLOCK; NC
22	11	EL-133-NO	CONTACT BLOCK; NO
27	1	EL-196	ROTARY SWITCH 7 POS
28	1	EL-134	LIGHT HOUSING
		EL-137-F	RED LENS; "FAULT"
29	1	EL-197	ROTARY SWITCH KNOB

Bottom Plate

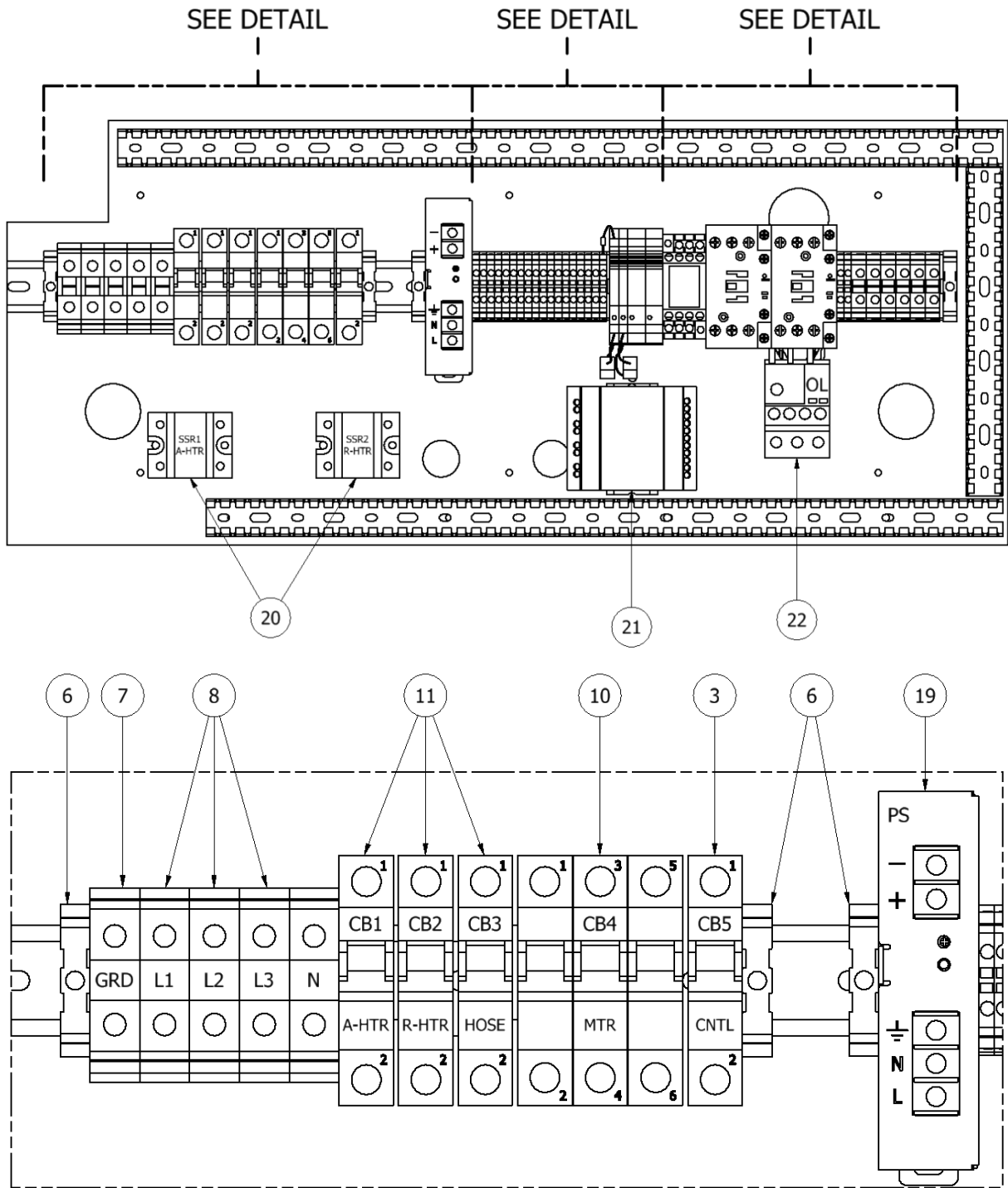

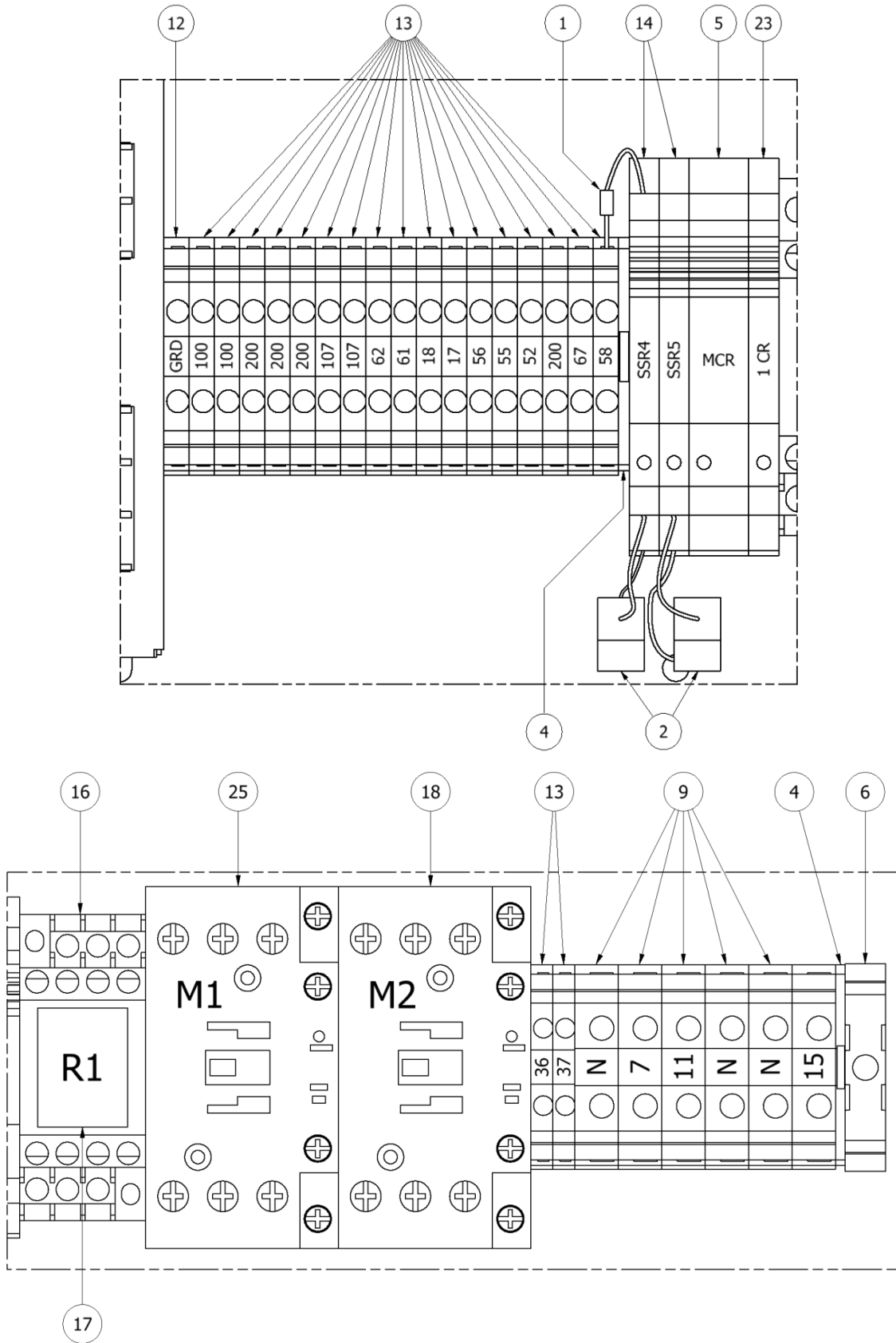

COMPONENT LIST			
ITEM	QTY	PART NUMBER	DESCRIPTION
1	1	EL-171	DIODE RECTIFIER; 1000V; 1A
2	2	EL-172	RESISTOR; 220 OHM; 5%; 3W; MET
3	1	EL-186	SINGLE POLE 3 AMP, BREAKER
4	2	EL-156-10	TERMINAL COVER 10MM/5.2MM
5	1	EL-174	SS RELAY; 24 VDC
6	4	EL-152	END STOP; 35MM
7	1	EL-146	TERMINAL BLOCK; 16MM; GROUND
8	5	EL-143	TERMINAL BLOCK; 16MM
9	5	EL-141	TERMINAL BLOCK; 10.2MM
10	1	EL-162	CIRCUIT BREAKER; 20A; 3 POLE
11	3	EL-191	CIRCUIT BREAKER; 32A; 1 POLE
12	1	EL-144	TERMINAL BLOCK; 5.2MM; GRND
13	19	EL-140	TERMINAL BLOCK; 5.2MM
14	2	EL-160	SS RELAY; 24VDC; 2A
15	1	EL-119	CONTACTOR; 25A; 24VDC COIL
16	1	EL-155	RELAY SOCKET
17	1	EL-154	LATCHING RELAY; 24VDC
18	1	EL-118	CONTACTOR; 32A; 24VDC COIL (FOR 120V TRANSFORMER)
	1	EL-119	CONTACTOR; 25A; 24VDC COIL (FOR 90V & 70V TRANSFORMER)
19	1	EL-122	POWER SUPPLY; 2.5A; 230VAC/24VDC
20	2	EL-34	RELAY; 50 AMP; 480V
21	1	EL-194-1	BAL CONT UNIT
22	1	EL-161	40-20A
23	1	EL-198	RELAY, SPDT, 24VDC
25	1	EL-125	CONTACTOR; 40A; 24VDC

Point to Point Diagrams

Incoming Power

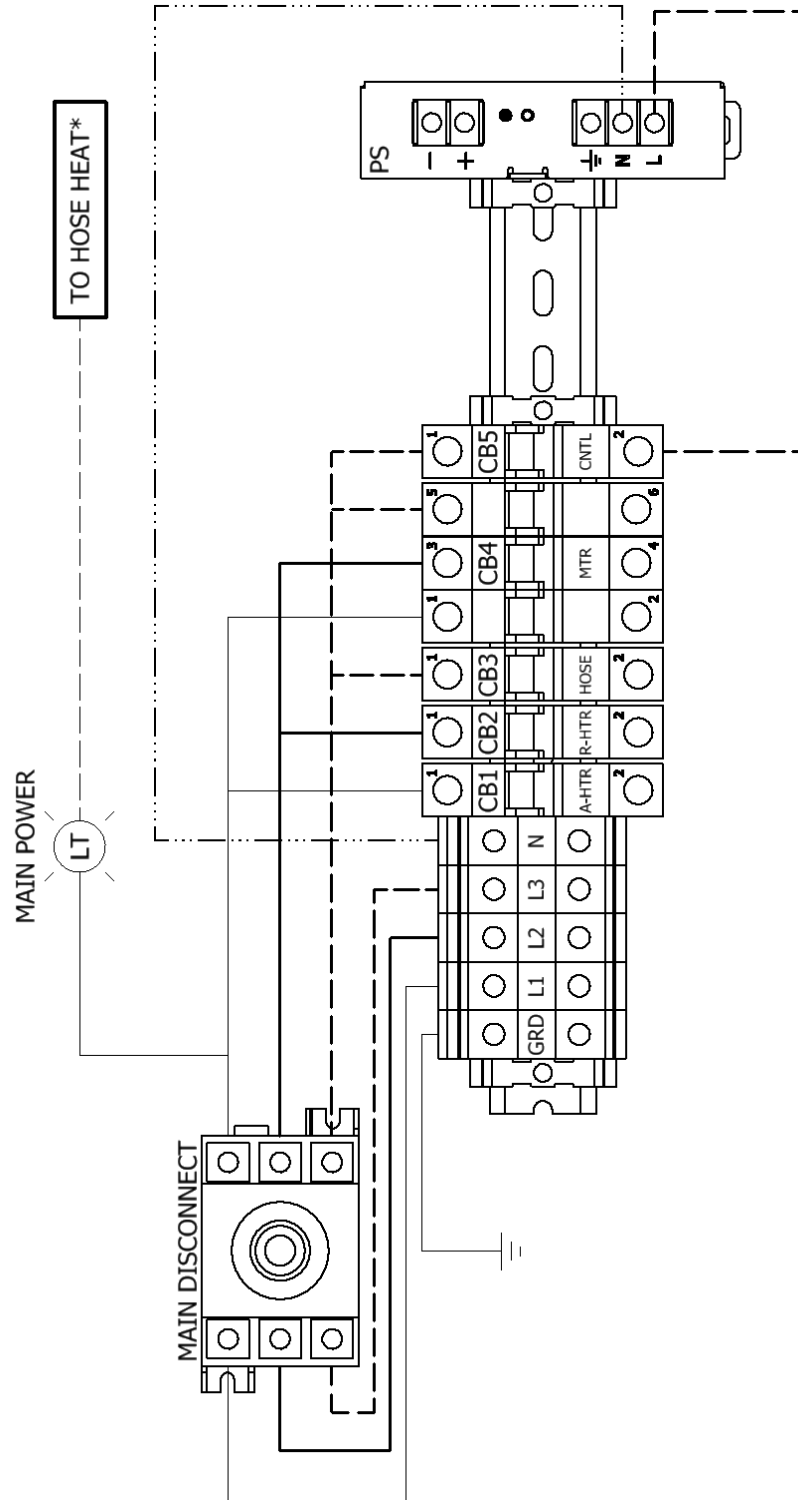

*See Heater Circuit (Pg. 45)

Heater Circuit

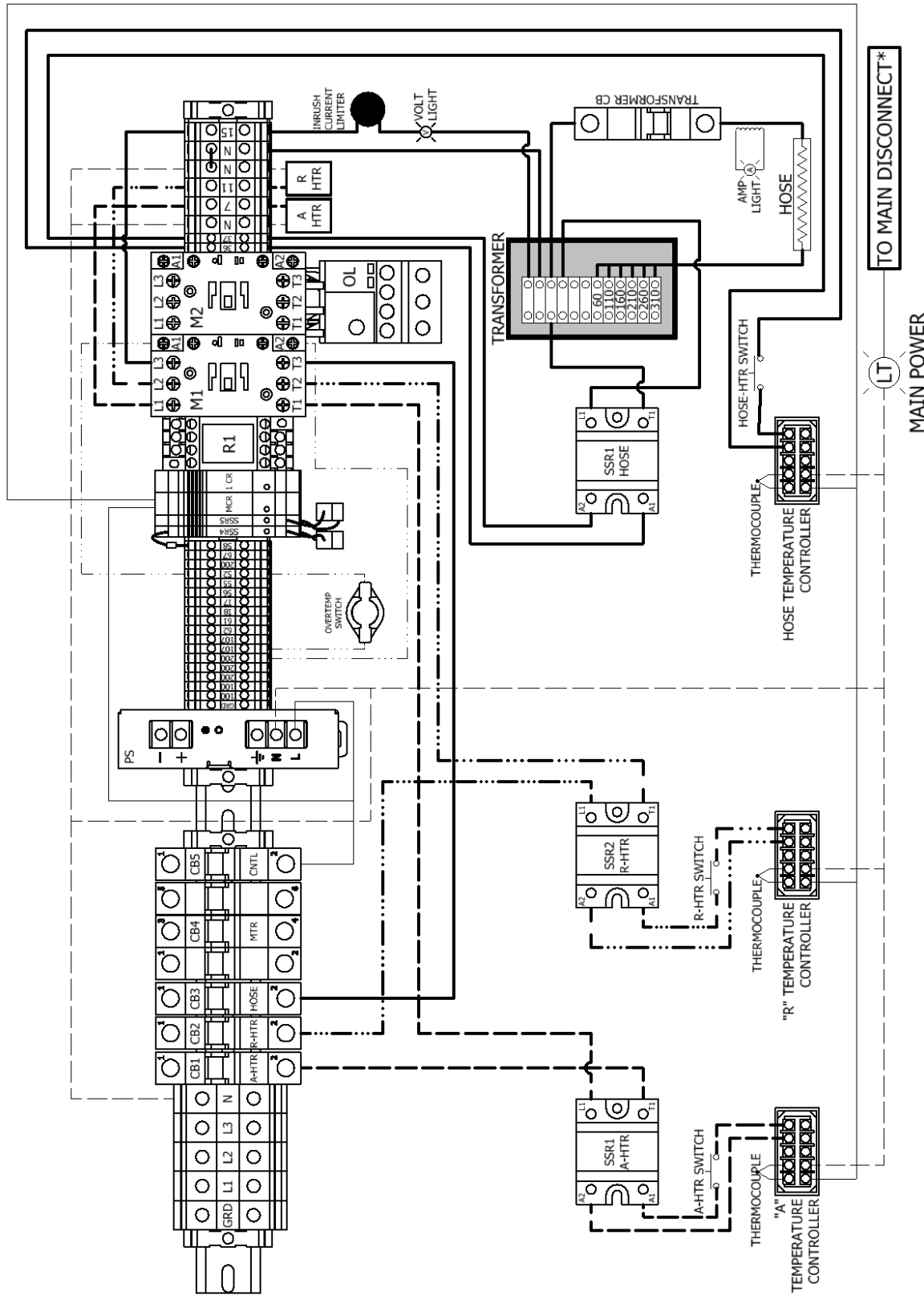

*See Incoming Power (Pg. 44)

Motor Circuit

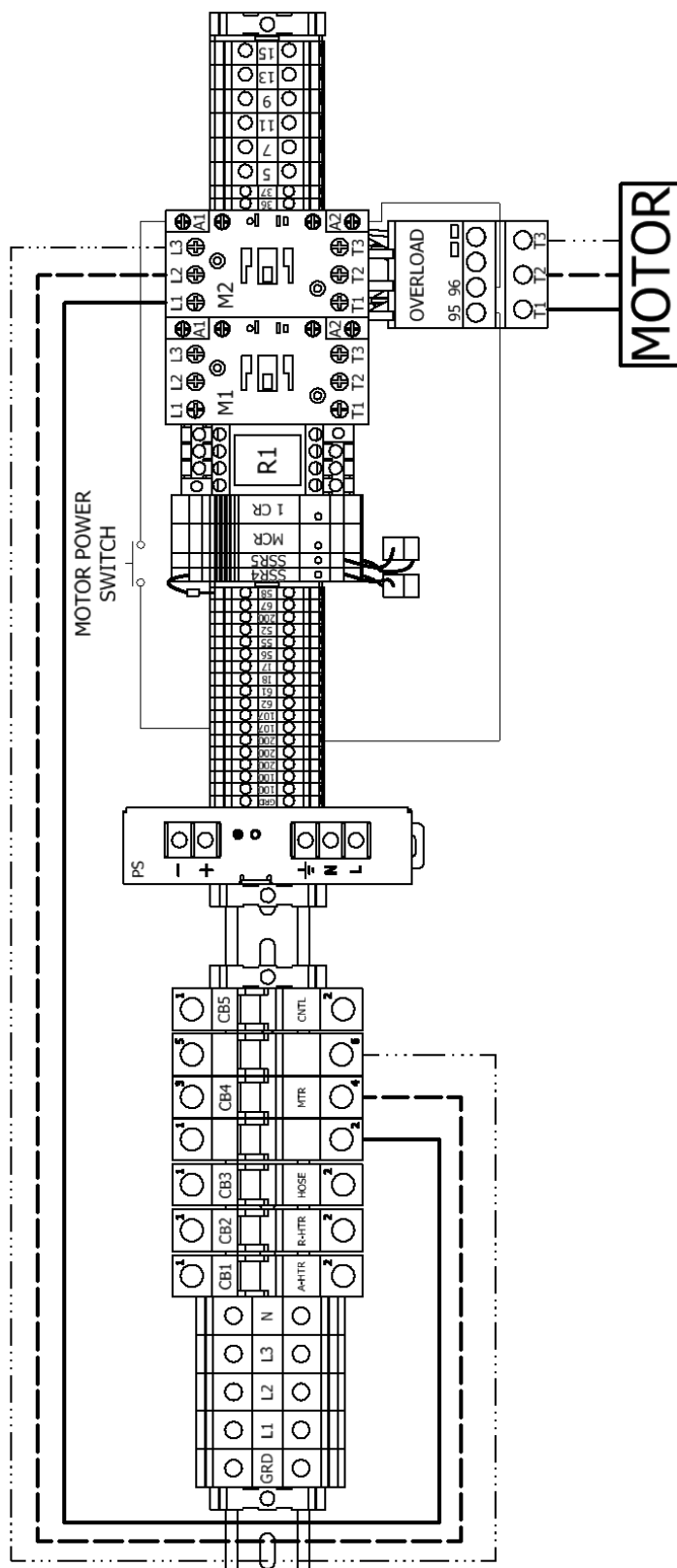

24 VDC Power Circuit

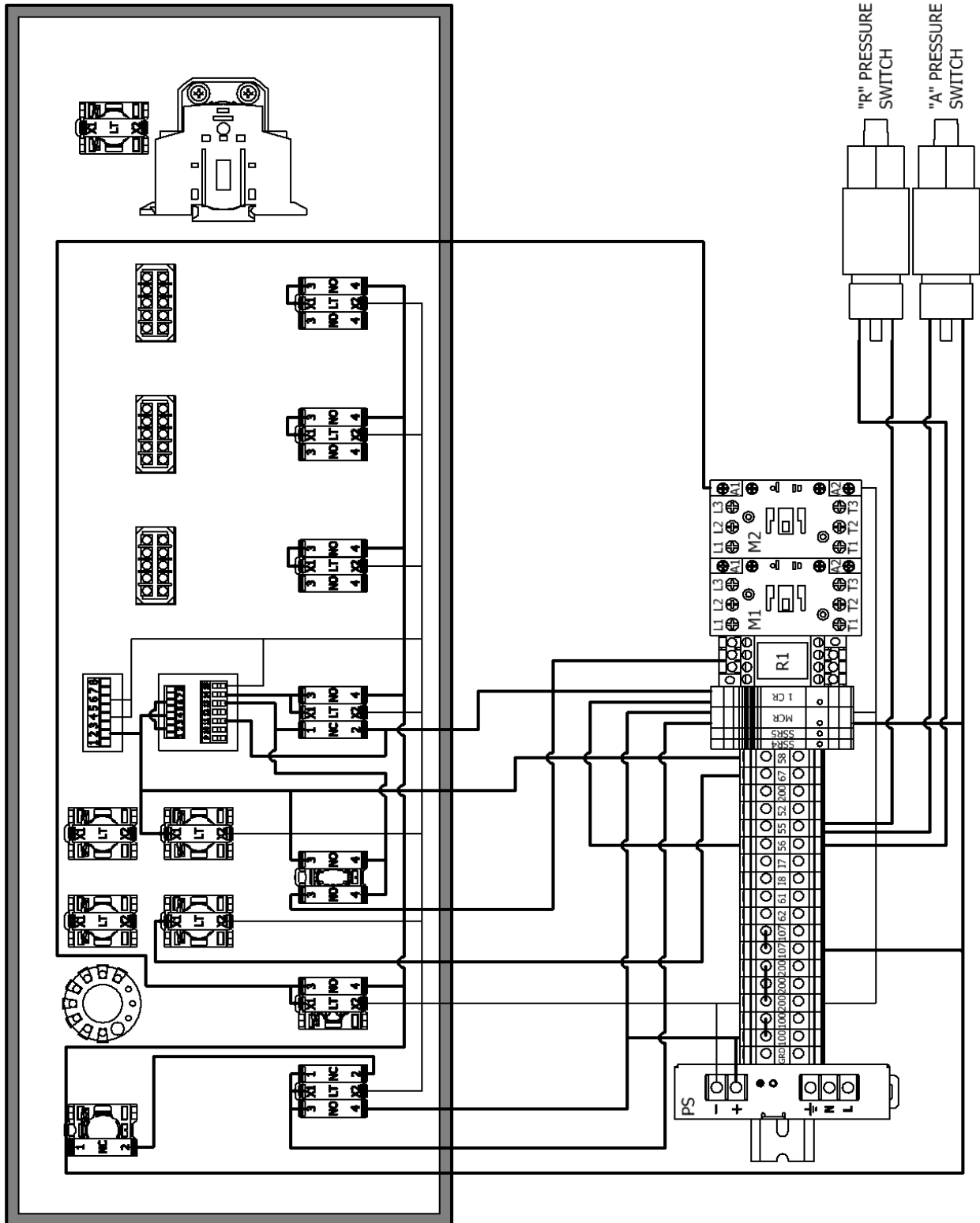

Pump Circuit

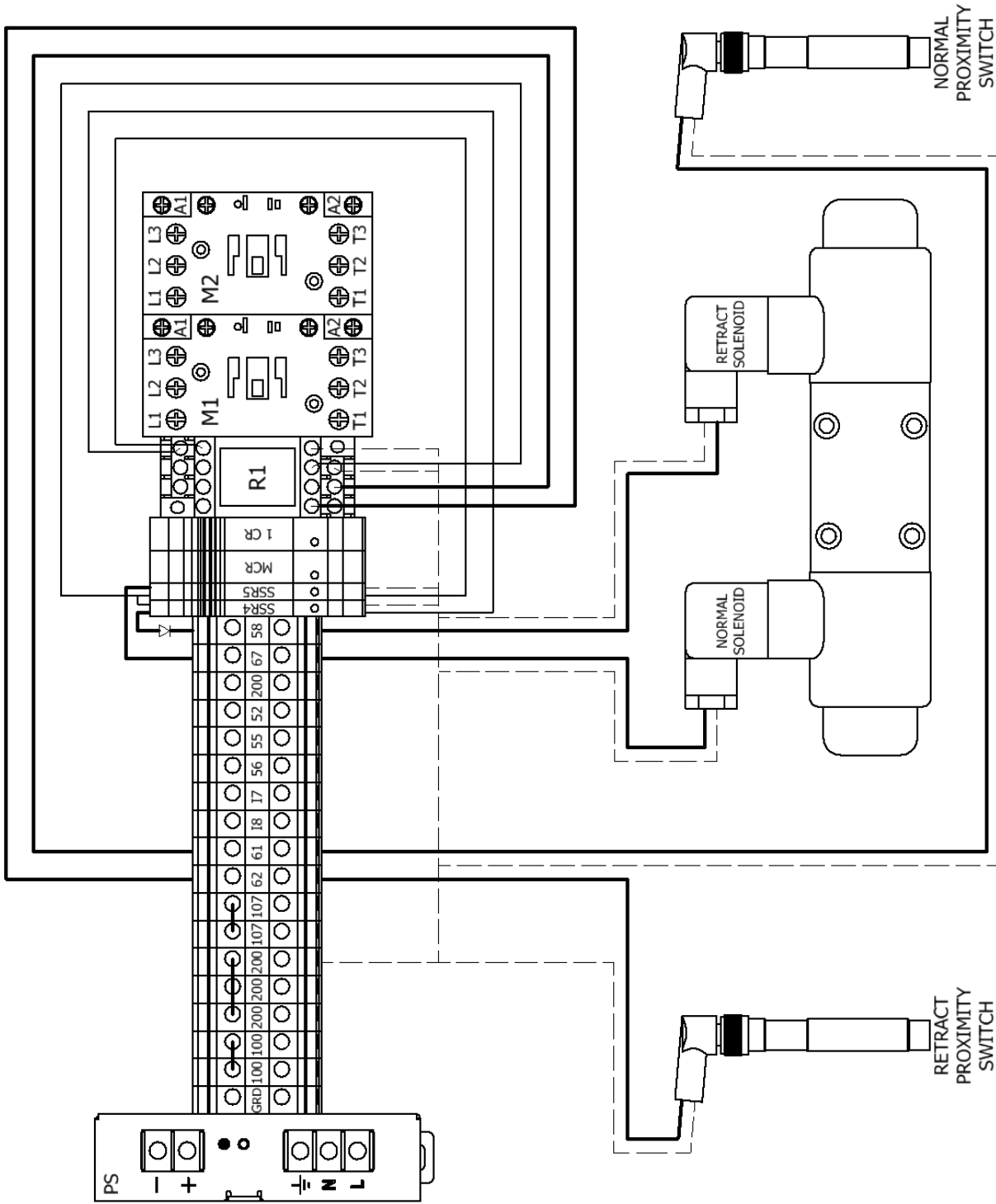

Pressure Balance Control Circuit

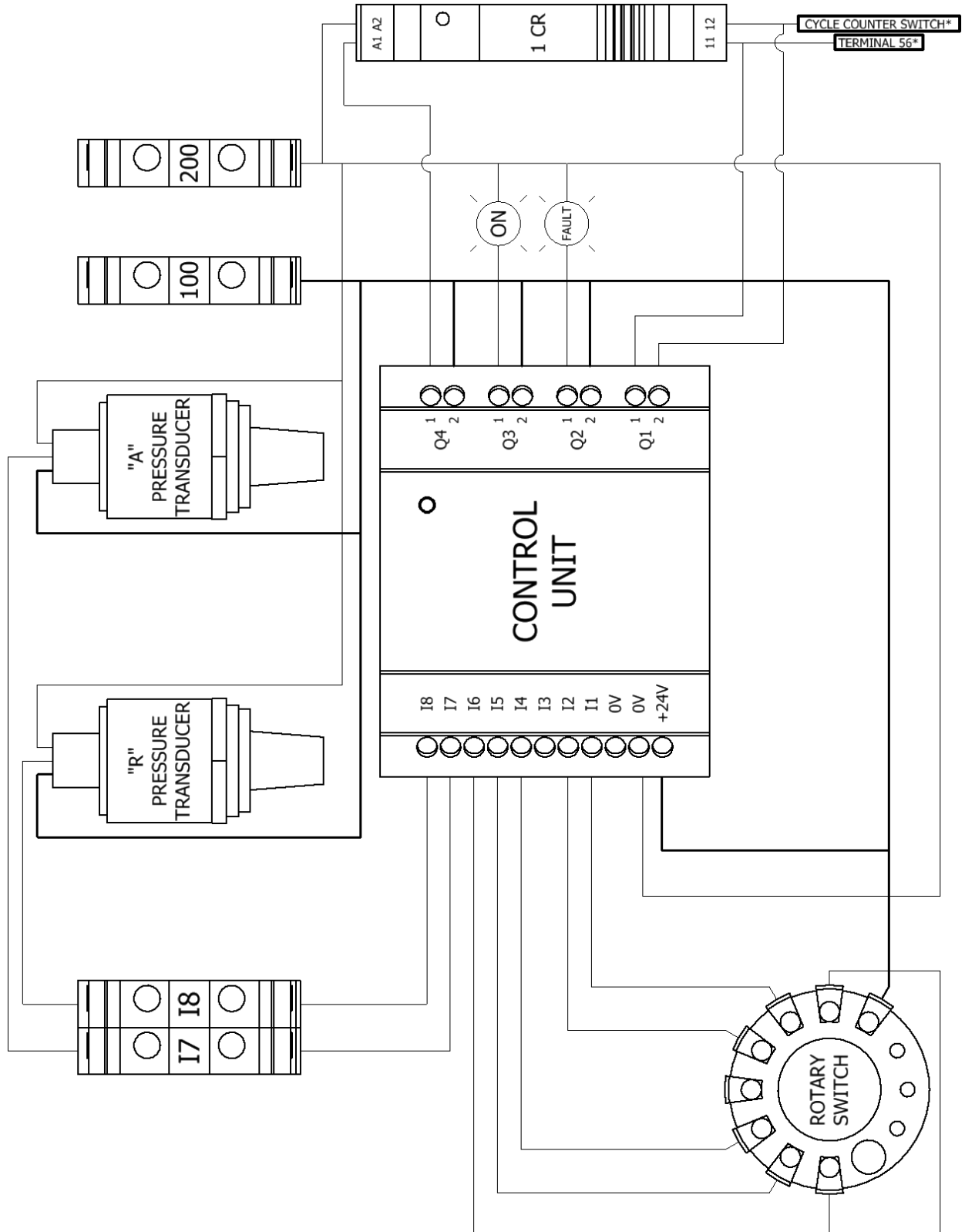

*See 24 VDC Power Circuit (Pg. 47)

Ladder Diagrams

Incoming Power

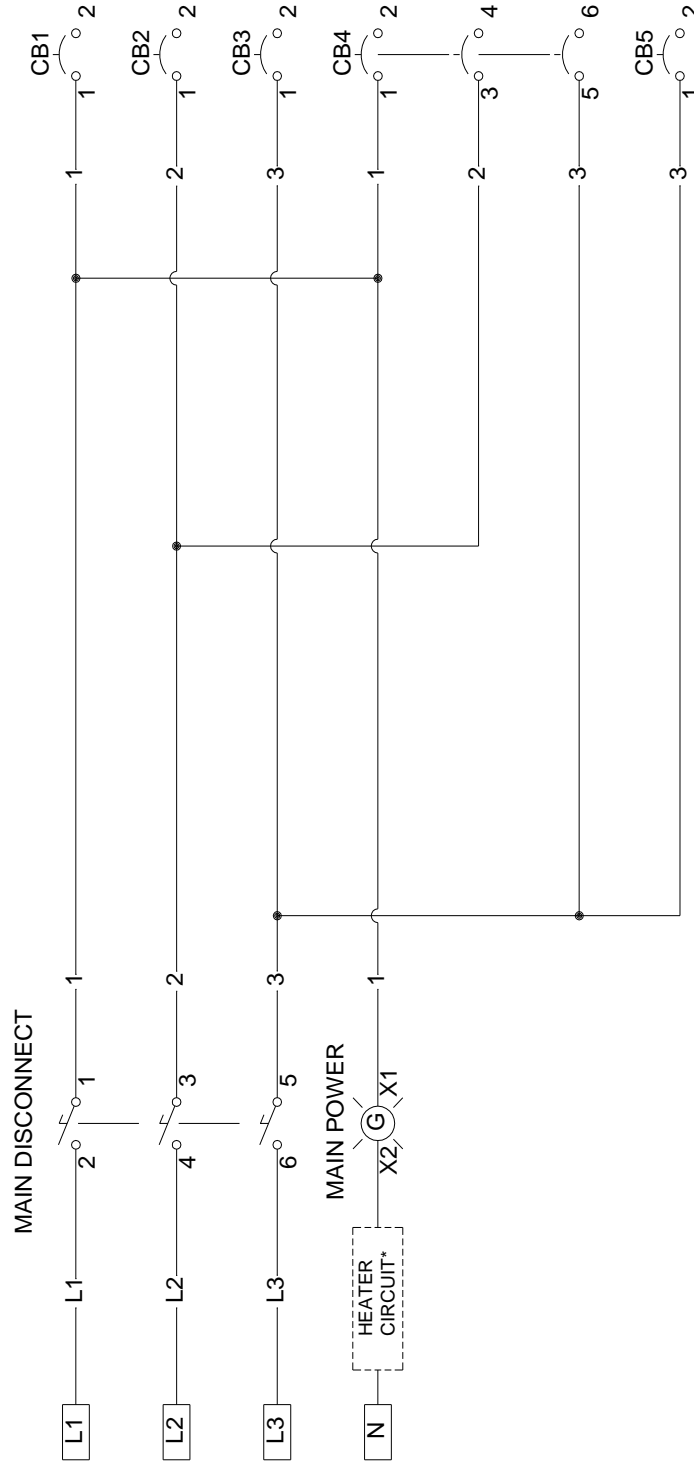

*See Heater Circuit (Pg. 51)

Heater Circuit

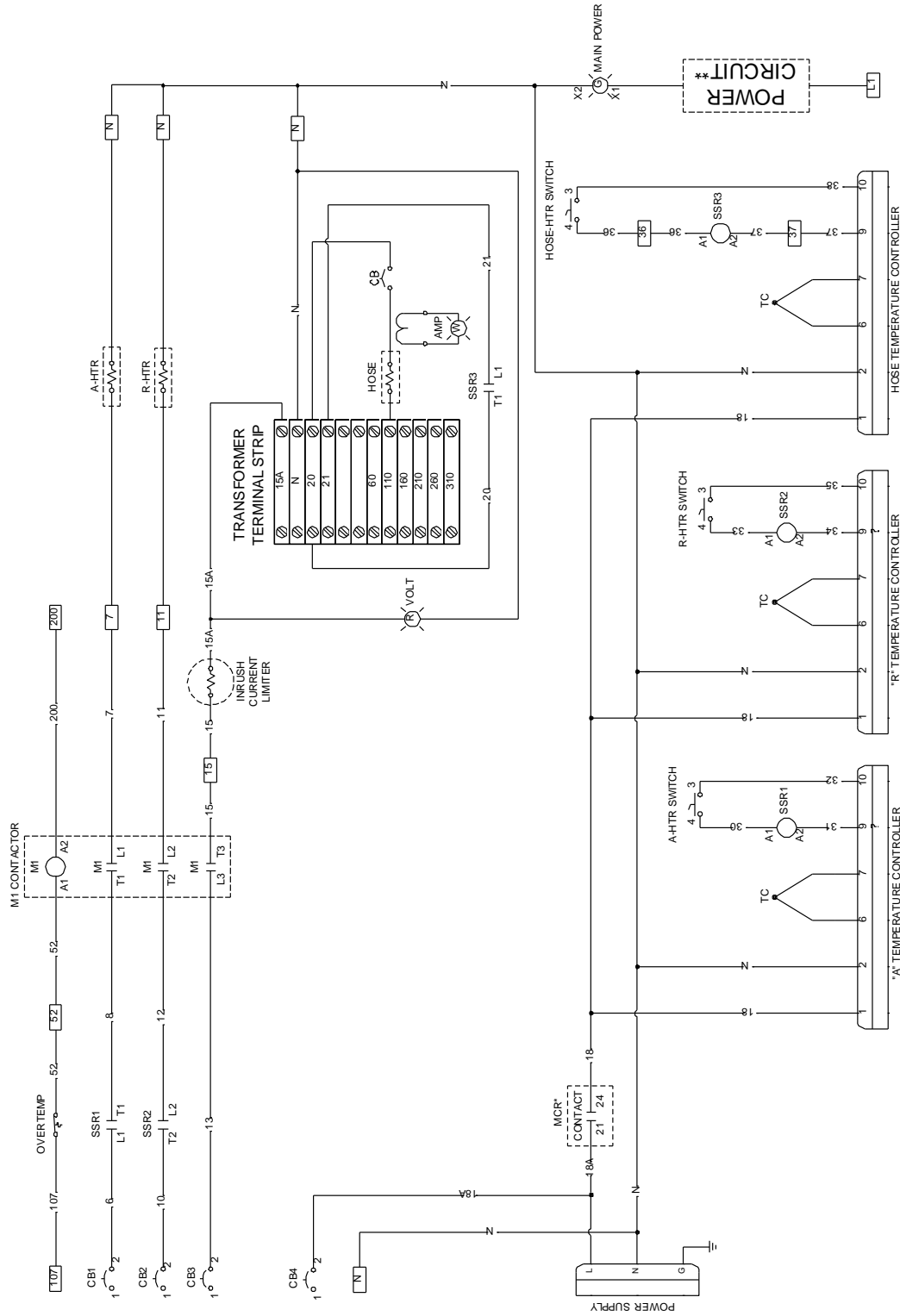

*See 24 VDC Power Circuit (Pg. 53) for complete MCR wire connections
 ** See Incoming Power (Pg. 50)

Motor Circuit

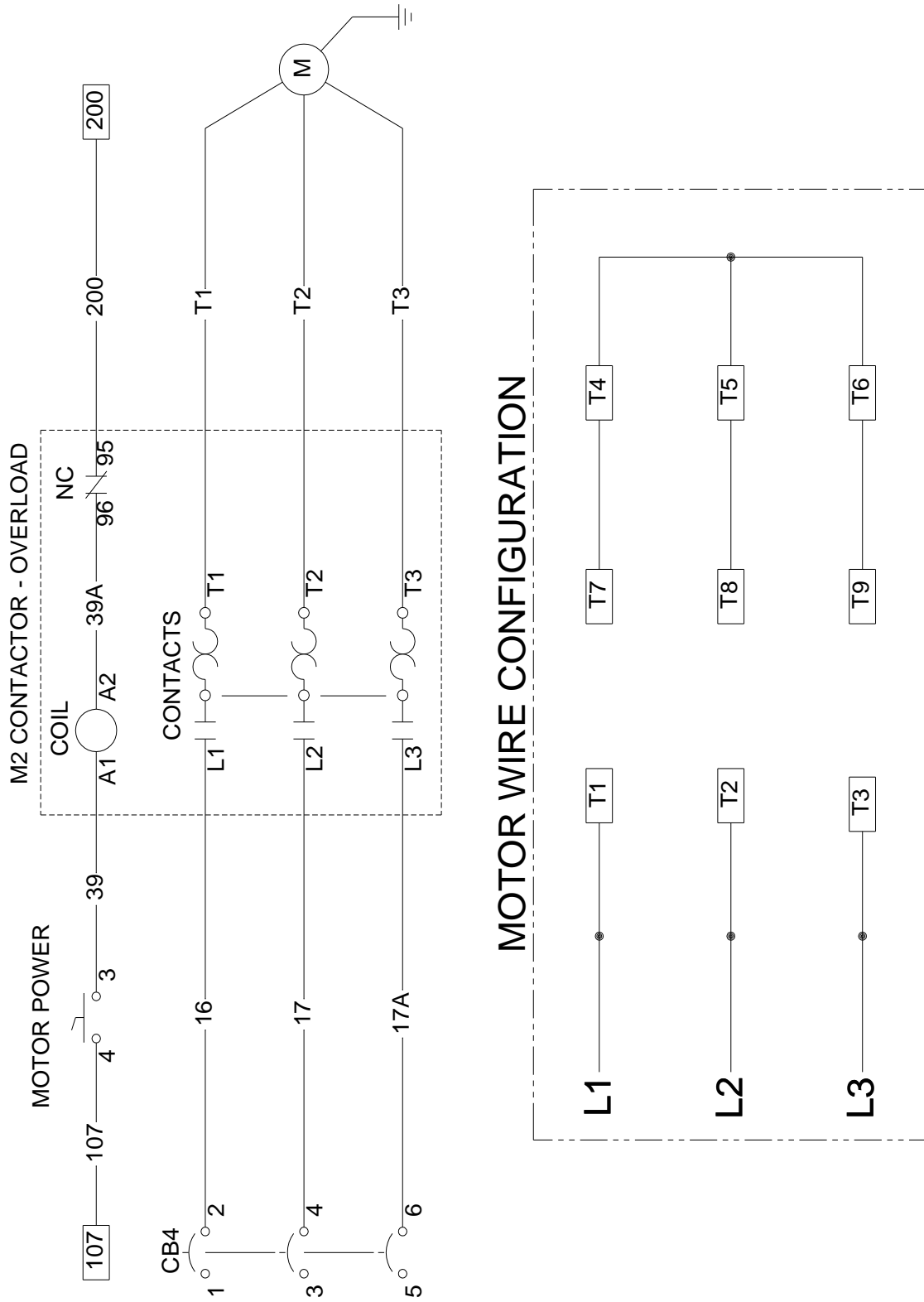

24 VDC Power Circuit

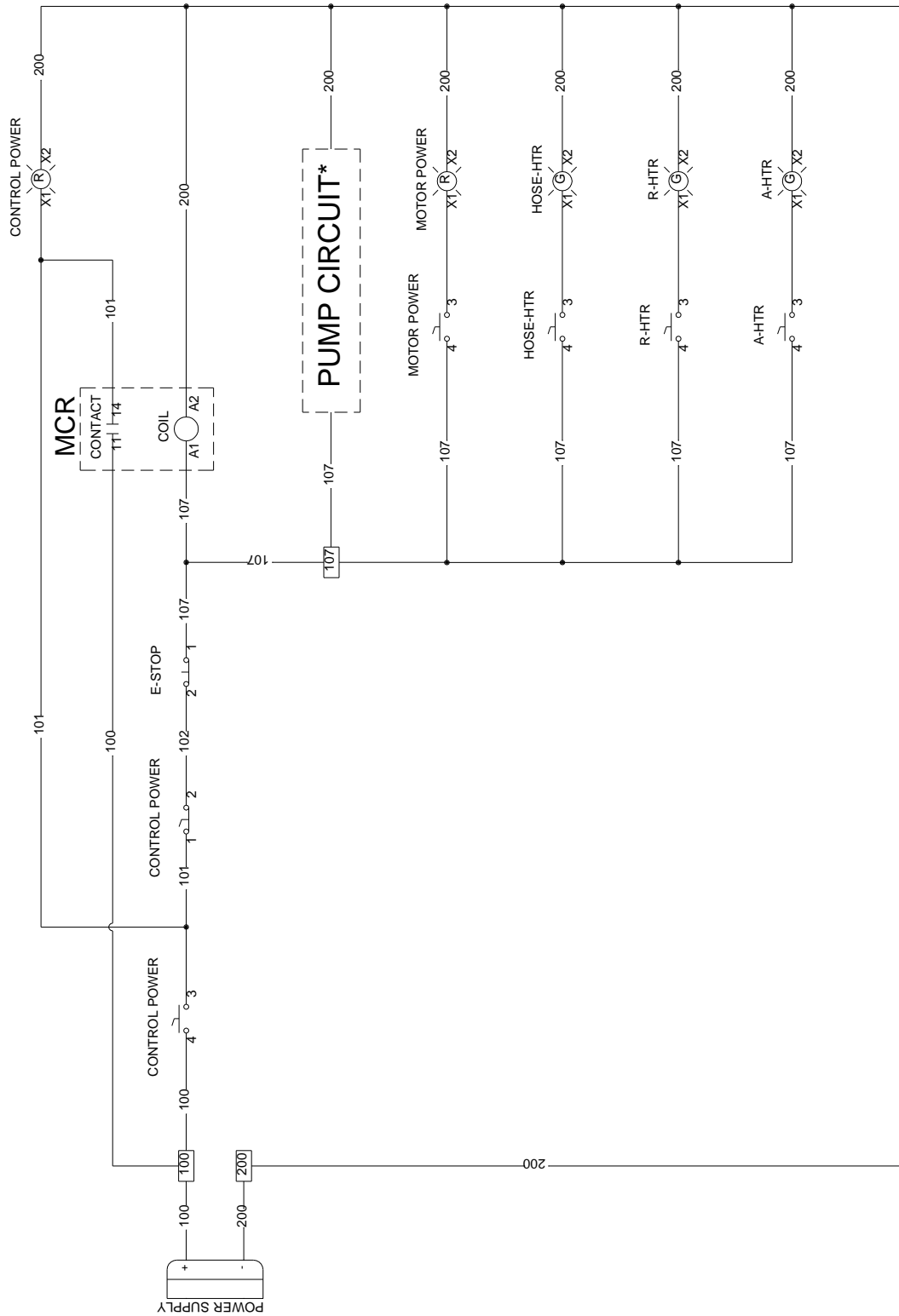

*See Pump Circuit (Pg. 54)

Pump Circuit

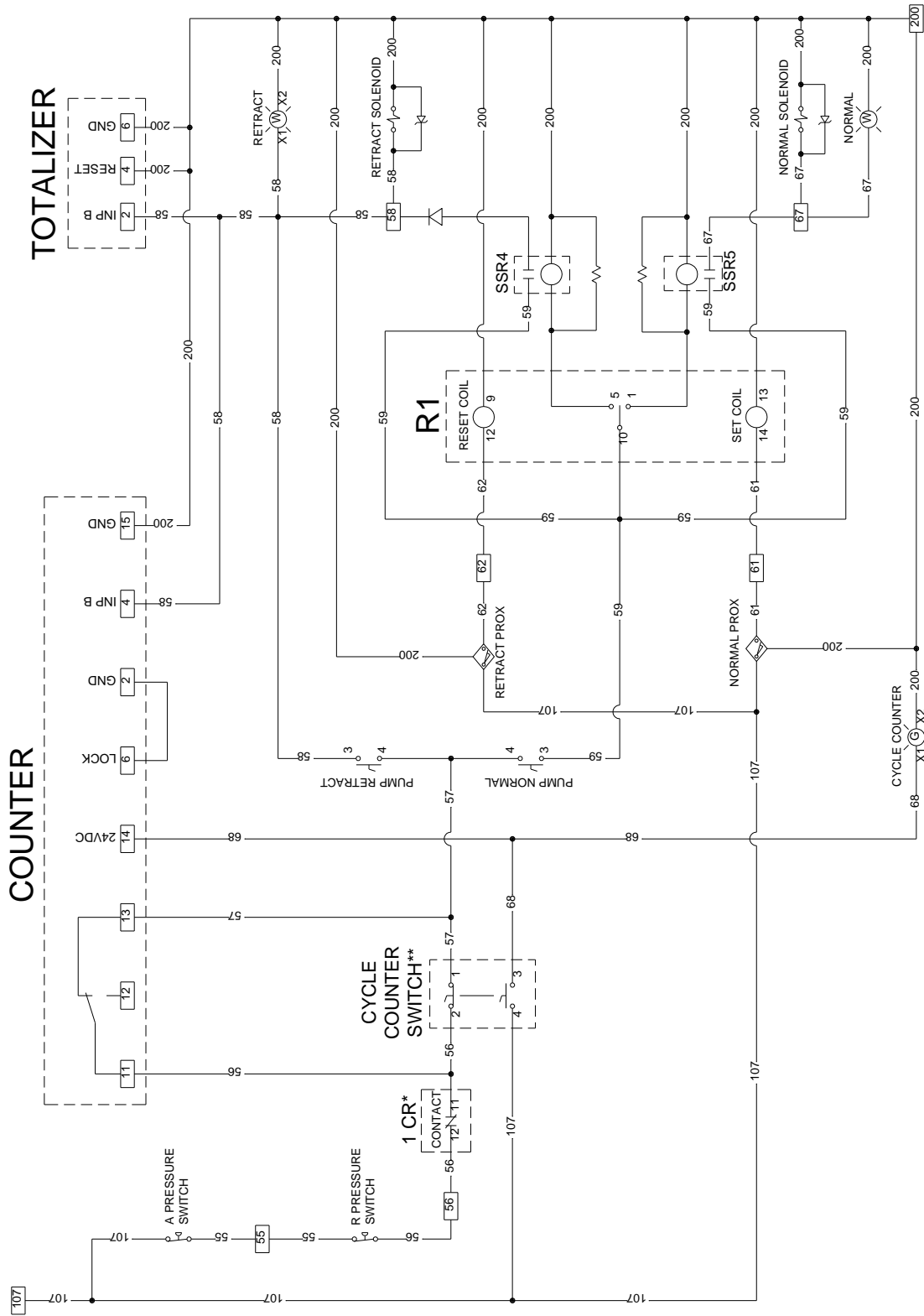

*See Pressure Balance Control Circuit (Pg. 55) for complete 1 CR wire connections

**When the cycle counter switch is turned "ON", the NC switch opens and the NO switch closes simultaneously

Pressure Balance Control Circuit

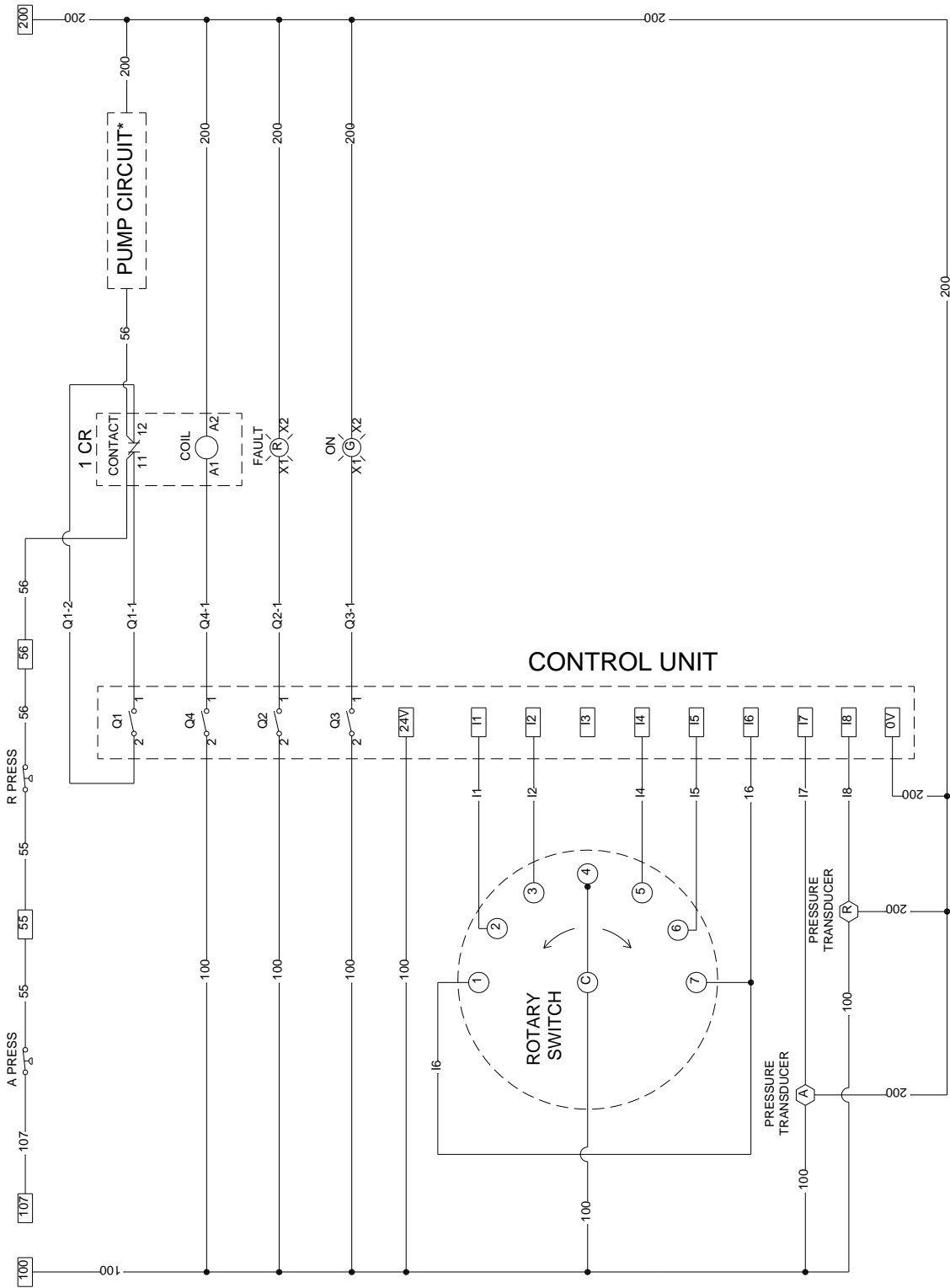

*See Pump Circuit (Pg. 54)

MANUAL REVISIONS

REVISION	DATE	CHANGES	APPROVED
1.0	29-Jan-15	INITIAL RELEASE	Vadams