



KRENDL™

The Innovator in Insulation Equipment



OWNERS MANUAL

MODEL #1300/2300



55 YEARS OF AMERICAN INGENUITY

**KRENDL MACHINE COMPANY • 1201 SPENCERVILLE AVE
DELPHOS, OHIO 45833 • TELEPHONE 419-692-3060 • FAX 419-695-9301
E - MAIL: krendl@krendlmachine.com • WEB SITE: www.krendlmachine.com**

CONGRATULATIONS ON YOUR PURCHASE OF KRENDL EQUIPMENT

**MODEL #1300/2300
OWNER'S MANUAL**

**FOR ASSURED SAFETY AND CONFIDENCE, PLEASE READ THIS
MANUAL CAREFULLY BEFORE INSTALLING AND OPERATING YOUR
MACHINE.**

**E-MAIL ADDRESS IS: krendl@krendlmachine.com
WEB SITE IS: www.krendlmachine.com**

Table of Contents

	PAGE
INTRODUCTION.....	1
GENERAL SAFETY INFORMATION.....	2-3
DECALS.....	4-5
WARRANTY.....	6
RETURNED GOODS PROCEDURE.....	7
SPECIFICATIONS.....	7
ASSEMBLY.....	8
BASIC COMPONENTS.....	9
OPERATING INSTRUCTIONS	
Machine Hook-up.....	10-12
Electrical Operation.....	13
Mechanical Settings.....	14-15
GENERAL MAINTENANCE.....	16-20
ELECTRICAL SYSTEM.....	21-28
LADDER DIAGRAMS.....	29-33
TROUBLESHOOTING.....	34-36
PARTS LIST.....	37-49
GLOSSARY.....	50
SERVICE RECORD.....	51

INTRODUCTION

Thank you for purchasing a **KREN DL INSULATION MOVING MACHINE**. With over fifty-five years experience in manufacturing insulation moving equipment, we have designed and built your machine with the highest quality to provide years of reliable service.

This manual has been prepared to help you obtain the maximum efficiency and service from your Krendl equipment. The machine is designed to condition and apply insulation with the utmost in dependable performance. Our primary objective is to build equipment which will provide complete satisfaction so that you may confidently recommend Krendl to others.

We do not manufacture or sell insulation. Our interest lies only in the proper performance of the equipment we manufacture. We make no recommendations or guarantees concerning various insulations.

CAUTION:

 This manual contains important information regarding the **safe** assembly and operation of your machine. We urge you to read it carefully and follow the instructions provided. If your questions are not answered in this manual, may we hear from you? We want you to be able to operate this unit safely and confidently.

UNPACKING: Store and unpack carton with correct side up. Unpack your machine **IMMEDIATELY** and check for damage in shipping. **Place any damage claim with delivering carrier, saving all packing materials for inspection.** Our warranty covers manufacturer's defects only. **DO NOT** return to shipper.

FILL IN AND RETAIN:

Krendl Machine Company
1201 Spencerville Ave.
Delphos, Ohio 45833 U.S.A.

Telephone: 419-692-3060
Fax: 419-695-9301
E-mail: krendl@krendlmachine.com
Web Site: www.krendlmachine.com

For your protection in the event of theft or loss, please fill in the information requested for your own records. This information will be needed for in-warranty repairs. You may also want to attach a copy of your invoice.

Machine model number _____ Blower motor manufacturer _____

Serial number _____ Agitator motor manufacturer _____

Blower(s) serial number(s) _____ Speed reducer manufacturer _____

Date of purchase _____ Supplier _____

The model and machine serial numbers are located on the hopper of the machine unit. The blower(s) serial number(s) is located on the motor housing of the blower(s). The motor(s) serial number(s) is located on the motor(s) housing and the reducer serial number is located on top of the reducer.

GENERAL SAFETY INFORMATION

 **Important:** Read **all** instructions **before** operating this unit. This equipment can be potentially dangerous and must be used in strict accordance with instructions.

 **Disclaimer Notice:** The manufacturer will not be legally responsible for any injury or damage resulting from the improper use of this equipment or the failure to follow instructions.

Unpacking

Handle cartons with care to avoid damage from dropping or bumping. Store and unpack cartons with the correct side up. Completely remove machine from the packaging and from any shipping pallet or skid to which it might be attached. In addition, completely remove all shipping materials from **inside** the machine.



General Safety

1. Read this manual carefully and become familiar with your machine unit. Know its applications, limitations, and any hazards involved.
2. This machine was designed and manufactured for specific applications. Do not attempt to modify the unit or use it for any application it was not designed for. If you have any questions about your intended use or the machines suitability, ask your dealer/distributor or consult the factory. The manufacturers' could not possibly anticipate every circumstance that might involve a hazard. For that reason, warnings in the manual and warning tags or decals affixed to the unit, are **not** all-inclusive. If you intend to handle, operate, or service the unit by a procedure or method not specifically recommended by the manufacturer, first make sure that such a procedure or method will not render this equipment unsafe or pose a threat to you and others.



Electrical Safety

- The **National Electric Code** (NEC) in the United States and many international electrical codes require frame and external electrically conductive parts of this machine to be properly connected to an approved earth ground. Local electrical codes may also require proper grounding of machine. Consult with local electricians for grounding requirements in your area.
- Never handle any kind of electrical cord or device while standing in water, while barefoot or while hands or feet are wet. Dangerous electrical shock will result.
- Use a ground fault circuit interrupter (GFCI) in any damp or highly conductive area. (metal decking or steel work)
- Reference NFPA 79, 70E, or OSHA safe work practices when performing energized work procedures.



Safety/Caution

- **Be Safe** - Keep away from moving parts.
- **Be Safe** - Make sure all guards and hopper bar are in proper place **before** operating machine. Guards and safety devices/switches should not be removed, modified or by-passed. Hands should **never** pass below hopper bar.
- **Be Safe** - Do not remove motors or lift hopper when unit is connected to power supply.
- **Be Safe** - Make sure machine is properly grounded. Protect all electrical supply cords from sharp objects, moisture, and other potentially hazardous materials. Keep power cords in good repair. Electrical service must be performed by a qualified electrician.
- **Be Safe** - Disconnect power supply **before** inspecting or adjusting unit.
- **Be Safe** - Consult a qualified technician to answer questions **before** attempting to operate, or injury may result.
- **Be Safe** - Do not operate machine alone.
- **Be Safe** - Do not leave machine unattended and energized.
- **Be Safe** - Turn machine off and disconnect electricity before clearing and feeding jam or attempting to remove any object dropped in the hopper.
- **Be Safe** - Keep hands, loose clothing, jewelry and hair away from agitators, gears, chains and other moving parts.
- **Be Safe** - Use proper lifting when moving insulation and loading machine.
- **Be Safe** - Keep work area clear of debris.
- **Be Safe** - Wear proper safety equipment, including protective gear, such as respirators, eye and ear protection.
- **Be Safe** - Violation of the Owner's Manual or safety precautions may void warranty.



Make Sure!

- Hopper is empty of foreign objects **before** starting.
- Adequate electrical power is supplied or damage to unit will result.
- Blower filter is kept clean and in place when blower is on.
- Machine is turned off **immediately** if hose is plugged, or blower will overheat.
- Machine must be on **before** adding insulation.
- Blower(s) must be on, when agitators are running, or machine will bind.
- Agitator motor is not run with hopper empty for more than a few minutes, or damage to seals will result.
- Sprockets, chains, belts and pulleys are correctly **aligned** and **tensioned**.
- Pieces of bag are **not** left in the machine as this can bind and stall your machine.
- This machine should only be used with good quality insulations that are dry, undamaged and that meet a certain industry specification or quality standards.

DECALS



Keeping the filter clean will result in longer blower life and better performances.



Rotating parts can be dangerous! You can snag clothes, hair, hands, etc. This can cause serious injury or death.



Manufacturer information is provided here along with machine model, and serial number.



Made in the U.S.A.



Emergency stop button for machine.



Opens and closes the material feed gate which in turn controls the production.



Identifies position of material feed gate.

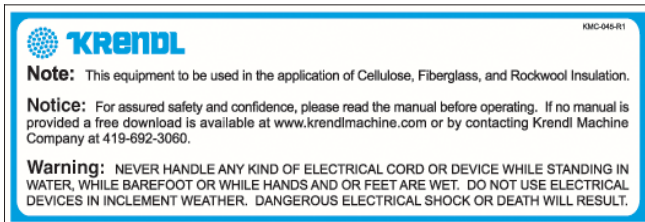

Identifies what type of insulation should be used with this machine and that the manual should be read before operating. Warns to be careful around electrical components! This can cause serious injury or death.



General safety information intended to reduce the risk of serious injury or death



Indicates if blower is off, on, or on with agitator.



Operating machine at specified voltage will result in longer machine life and better performance.



Specifies the voltage this outlet is rated for.



Indicates that this outlet is intended for only the remote control outlet. Each time machine cycle starts, an audible alarm warns the operator that the machine is about to come on.



Indicates that this outlet is intended for only the wireless remote. Each time machine cycle starts, an audible alarm warns the operator that the machine is about to come on.

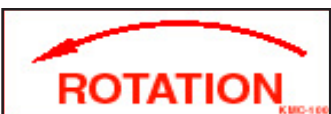

Rotating parts will be moving in this direction.



Part number for identification and tracking.



Reset button for motor.



Indicates this unit has two power sources that should be disconnected before servicing to reduce the risk of serious injury or death.



Indicates the input power of the machine.

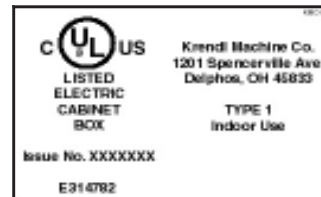

Indicates that the electrical box on the machine is in compliance with UL codes.



Indicates which employee date equipment was inspected.



Identifies if machine is in remote mode, manual mode, or off position. In manual mode this switch operates machine. In remote mode the hand pendant operates machine. Each time machine cycle starts, an audible alarm warns the operator that the machine is about to come on.

WARRANTY:

Krendl Machine Company (Company) warrants to each original purchaser (Buyer) of its machines that such products will be free of manufacturing defects for a period of 2 years from the date of shipment to the Buyer. (This does not include accessories, pumps, blowers, wall scrubbers, etc.)

No warranty is made with respect to:

1. Components or accessories manufactured and warranted by others. Warranties for purchased component parts as supplied from vendor such as engine, electric motor, blower, gearbox, transmission, etc., if furnished by the manufacturer of the component, are on file at the Company's main office and copies will be furnished at request of Buyer. Component(s), shipping costs prepaid, shall be sent to Company who in turn shall forward to vendor for evaluation and warranty determination.
2. Any defect caused by repair, alteration and/or adjustment performed by Buyer or customer/ vendor of Buyer without the express written authorization of the Company.
3. The labor costs of replacing parts by parties other than the Company.
4. Any machine that has not been operated and/or maintained in accordance with normal industry practice and the written recommendations of the Company. (e.g. machine operated with an improperly sized, worn or damaged hose, improper or inattention to preventative maintenance, etc.)
5. The product has been subjected to misuse, negligence or accident or results of any application or use of the blowing equipment not in accordance with the Company recommendations.

This limited warranty does not cover the free replacement of component parts that become inoperative due to wear and usage and need to be replaced on a regular basis, including but not limited to: airlock seal(s), agitator(s), shredder(s), auger(s), fuse(s), switch(es), clutch(es), hose(s), shaft seal(s), chain(s), belt(s), sprocket(s), pulley(s), bearing(s), cable(s), battery(ies), filter(s), fan(s), etc.

The Company's obligation under this warranty is limited to repairing or replacing (at Company option) any part that is determined by the Company to be suffering from a manufacturing defect. The Company (at Company option) will provide any required parts and labor to the Buyer. If the equipment or parts must be returned to the Company for repair, all transportation costs shall be the Buyer's responsibility.

THIS LIMITED WARRANTY IS EXPRESSLY IN LIEU OF ANY OTHER GUARANTEES AND / OR WARRANTIES, ORAL OR WRITTEN, EXPRESSED OR IMPLIED, INCLUDING WITHOUT LIMITATION, THE IMPLIED WARRANTY OF MERCHANTABILITY. NO WARRANTY, EXPRESS OR IMPLIED, OTHER THAN THE AFORESAID WARRANTY IS MADE OR AUTHORIZED BY COMPANY. COMPANY SHALL NOT BE LIABLE FOR ANY DIRECT, INDIRECT, INCIDENTAL OR CONSEQUENTIAL DAMAGES TO PROPERTY OR INJURY TO ANY PERSON OR COSTS ASSOCIATED WITH LOSS OF PRODUCTION RESULTING IN LOSS OF REVENUE, PROFITS OR LOSS OF EQUIPMENT THROUGH THE USE OF THIS EQUIPMENT.

Note: Special job circumstances incurring costs for specialized repair and next day delivery of parts will not be reimbursed by the manufacturer unless authorized by factory.

RETURNED GOODS PROCEDURE:

IF MACHINE WAS NOT PURCHASED DIRECTLY FROM KRENDL MACHINE COMPANY, CONTACT YOUR SUPPLIER / DISTRIBUTOR.

When returning products to Krendl for repair, first obtain a return goods authorization, at which time you will be given shipping instructions. The product must be shipped **PREPAID**:

Krendl Machine Company
1201 Spencerville Ave.
Delphos, Ohio 45833 U.S.A.

Telephone: 419-692-3060
Fax: 419-695-9301
E-mail: krendl@krendlmachine.com
Web Site: www.krendlmachine.com

Once the unit is received, it will be inspected. In-warranty units will be repaired and returned immediately. An estimate of repair charges will be provided for out-of-warranty units.

SPECIFICATIONS

MODEL #:	1300	2300
AIRLOCK DIAMETER:	12"	12"
AIRLOCK LENGTH:	12"	16"
OVERALL HEIGHT:	68"	68"
LOAD HEIGHT:	51"	51"
WIDTH (Depth):	32"	32"
LENGTH:	62"	62"
WEIGHT (Pounds):	757	846
ELECTRICAL:	120 or 240VAC	120 or 240VAC
BLOWER VOLUME (cfm):	188	188
BLOWER PRESSURE (psi):	4.5	4.5
AIRLOCK OUTPUT (Diameter):	3"	3"
MAXIMUM FEED RATES:		
Cellulose lbs./hr.	2400	3000
Fiberglass lbs./hr.	800	1000

WARNING: Recommended hose size, type and length must be used to achieve maximum results. Krendl cannot guarantee performance of the machine if hoses are under-sized, worn, damaged, or hoses other than those we recommend are used.

BEFORE YOU RUN THIS MACHINE...PLEASE READ THE REST OF THIS MANUAL!!

ASSEMBLY

Prior to packing, your machine has been assembled and tested to assure quality performance. However, to safeguard against damage in shipping, certain items are packaged separately within your carton and will need assembly. Remove extra drive chain which may be used later to change shredder direction for other applications.

BLOWER DOOR: (See Illustration A)

(Blower Filter must remain in Blower Door.) An appropriate size hose (NOT SUPPLIED) is attached to the Blower Door input tube and the other end is located elsewhere to provide clean air to blowers. A fine screen (NOT SUPPLIED), acting as a filter, over end of hose eliminates accumulation of unwanted debris. This will eliminate frequent cleaning of the Blower Filter. (Frequent inspection of input hose is recommended.)

POWER CORDS: (20-30 amp twist lock inputs only)

Female receptacle(s) need to be wired properly to main power cord(s). (For 240 volt 60 hz. see illustration E and consult electrician for assistance.) Units shipped to European countries will have standard (2) two prong 230V 16 amp plugs supplied. Units shipped overseas to other than Europe do not have plugs and receptacles on input cords due to the varying electrical plug configurations in different countries, unless provided by Krendl agents or suppliers.

SLIDEGATE HANDLE:

Prior to packing, the slidegate handle was assembled backwards to safeguard against damage in shipping. Remove handle and reinstall, so handle sticks out back of machine. **Do not** over tighten nut, so handle is free to spin.

ASSEMBLY OF OPTIONS: (See illustration A)**5" Wheel Package:** (standard or heavy duty)

Attach two swivel casters on airlock end of machine for increased mobility. Mount rigid casters on blower end with the hex bolts provided.

Bushing Reducer: (3" output)

Bushing reducer inserts into output tube of airlock. Press reducer firmly against shoulder and tighten two hold-down bolts to secure unit in place. The bushing reduces the size of opening at the airlock to match the hose, providing a more consistent feed while preventing plugged hoses. (Standard output tube on model #1300 and #2300 is 3".)

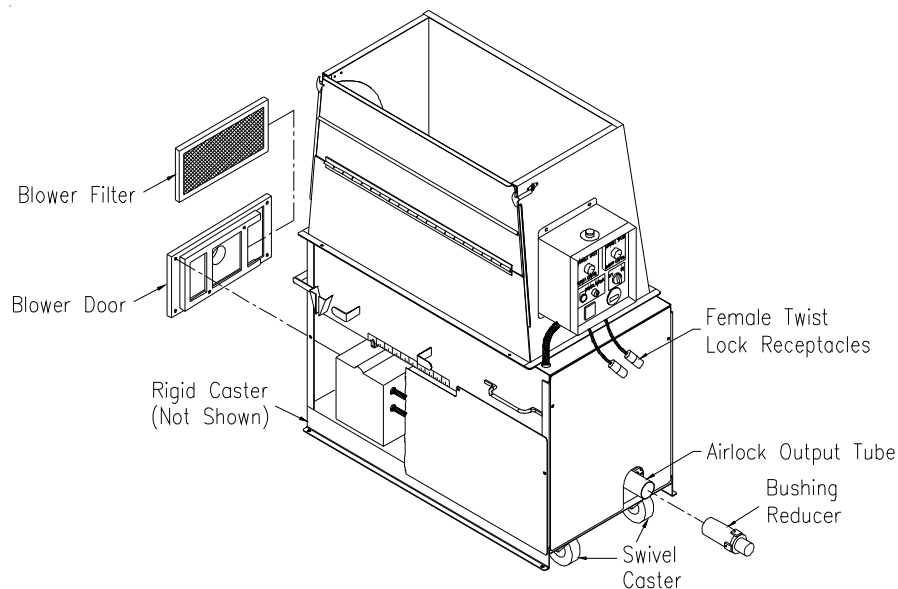
**(Illustration A)**

BASIC COMPONENTS

This is a view of the basic components of your machine. It shows the location of each item and gives the function of each. Use this as a guide throughout the manual.

- A) BASE UNIT** — Lower frame unit supporting blower system, speed reducer, motor, airlock and hopper.
- B) AIRLOCK** — Traps air and insulation while providing a metered flow.
- C) SLIDEGATE** — Meters the amount of insulation dropping into the airlock by controlling size of airlock opening.
- D) SPEED REDUCER** — Reduces speed of agitators/airlock drive motor while output power remains constant.
- E) BLOWER SYSTEM** — Unit includes blowers, check valve protection, filter and blower control.
- F) MOTOR** — Provides driving power for speed reducer and agitator/airlock system.
- G) AGITATOR** — Conditions and augers insulation in the hopper.
- H) HOPPER** — Upper unit of machine holding insulation which includes hinged access door.
- I) REMOTE CORD HANGER** — Storage for remote control cord.
- J) KILL SWITCH** — Safety device for immediate stopping of machine. (Located on electrical box)
- K) SHREDDER SYSTEM** — Increases production and coverage on all insulation products while reducing clumps that may exist in various insulations.
- (L) MAIN CONTROL PANEL** — Connects with main power, allowing operation of unit at machine or Remote Cord.

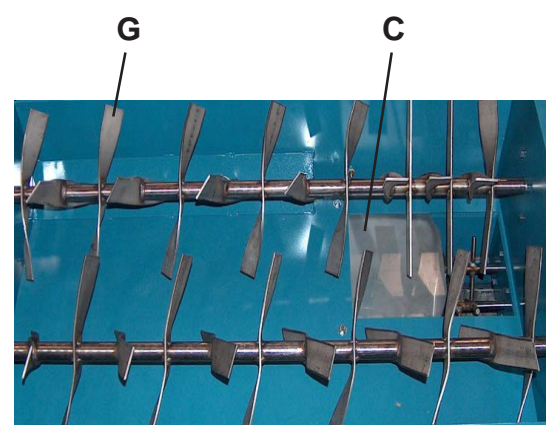
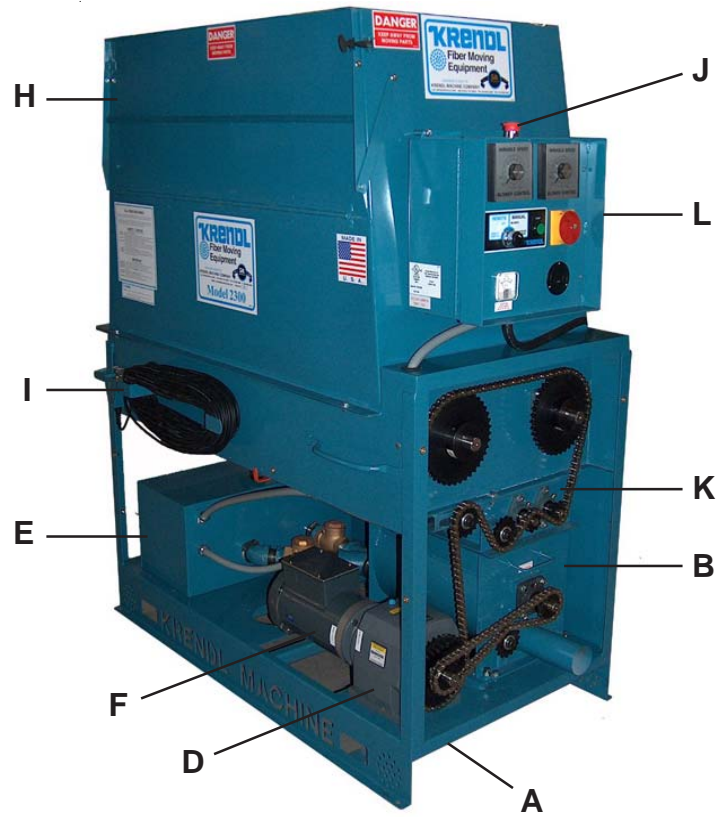

(Illustration B)

OPERATING INSTRUCTIONS**Machine Hook-up**

This unit comes ready for connection to insulation hose, power cords, and accessories.

The #1300 and #2300 provide a direct connection to 3" insulation hose. Slide hose on to outlet and secure with a hose clamp. All hose connections **must** have hose clamps to prevent air leakage from blower to nozzle. This helps to prevent hose plugging.

! Remove remote control cord, packet, accessories, ect. from hopper and plug remote control cord into **Main Control Panel Box** located on hopper. (See Illustration C)

The first bag of insulation into hopper should be well broken by hand to assist agitator action. **Caution: Never** put hands in hopper when machine is running or force feed material by pushing down on insulation.

! When assembling unit, make sure remote control **hand pendant** switch is in the **off** (middle) position and close **slidegate**.

1. Connect power to Input Cord(s) located below Main Control Panel. (See Illustration C)
On double input units, **both** input cords must be supplied with power from two separate sources for unit to work properly. One 20 amp plug must be plugged into one circuit and the 30 amp plug plugged into a separate circuit from the 20 amp. When using extension power cords, wire gauge size should not be less than input cord on unit and not to exceed 50' in length. **(See Voltage Drop Chart On Next Page.)**

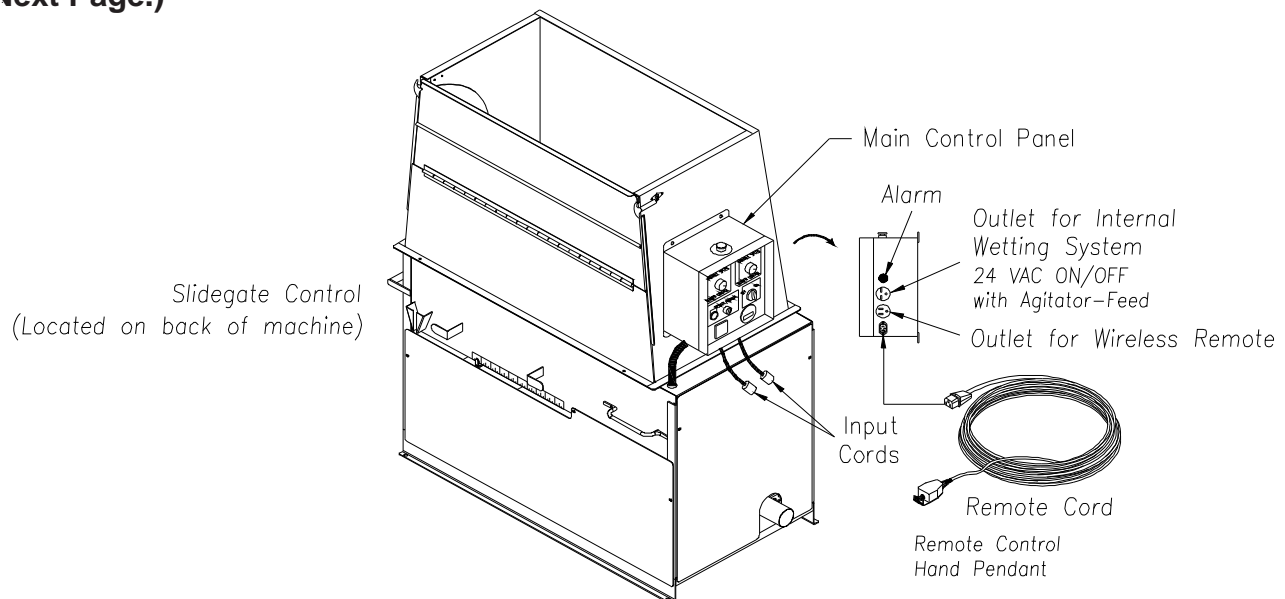

(Illustration C)

VOLTAGE DROP CHART

Typical voltage drop values based on conductor size and one-way length* (60 C termination and insulation)

25 FEET									
AMPERES		12 AWG	10 AWG	8 AWG	6 AWG	4 AWG	3 AWG	2 AWG	1 AWG
20		1.98	1.24	0.78	0.49	0.31	0.25	0.19	0.15
30			1.86	1.17	0.74	0.46	0.37	0.29	0.23
40				1.56	0.98	0.62	0.49	0.39	0.31
50					1.23	0.77	0.61	0.49	0.39
60						0.93	0.74	0.58	0.46

50 FEET									
AMPERES		12 AWG	10 AWG	8 AWG	6 AWG	4 AWG	3 AWG	2 AWG	1 AWG
20		3.95	2.49	1.56	0.98	0.62	0.49	0.39	0.31
30			3.73	2.34	1.47	0.93	0.74	0.58	0.46
40				3.13	1.97	1.24	0.98	0.78	0.62
50					2.46	1.55	1.23	0.97	0.77
60						1.85	1.47	1.17	0.92

75 FEET									
AMPERES		12 AWG	10 AWG	8 AWG	6 AWG	4 AWG	3 AWG	2 AWG	1 AWG
20		5.93	3.73	2.34	1.47	0.93	0.74	0.58	0.46
30			5.59	3.52	2.21	1.39	1.1	0.87	0.69
40				4.69	2.95	1.85	1.47	1.17	0.92
50					3.69	2.32	1.84	1.46	1.16
60						2.78	2.21	1.75	1.39

100 FEET									
AMPERES		12 AWG	10 AWG	8 AWG	6 AWG	4 AWG	3 AWG	2 AWG	1 AWG
20		7.90	4.97	3.13	1.97	1.24	0.98	0.78	0.62
30			7.46	4.69	2.95	1.85	1.47	1.17	0.92
40				6.25	3.93	2.47	1.96	1.56	1.23
50					4.92	3.09	2.45	1.94	1.54
60						3.71	2.94	2.33	1.85

125 FEET									
AMPERES		12 AWG	10 AWG	8 AWG	6 AWG	4 AWG	3 AWG	2 AWG	1 AWG
20		9.88	6.21	3.91	2.46	1.55	1.23	0.97	0.77
30			9.32	5.86	3.69	2.32	1.84	1.46	1.16
40				7.81	4.92	3.09	2.45	1.94	1.54
50					6.15	3.86	3.06	2.43	1.93
60						4.64	3.68	2.92	2.31

150 FEET									
AMPERES		12 AWG	10 AWG	8 AWG	6 AWG	4 AWG	3 AWG	2 AWG	1 AWG
20		11.85	7.46	4.69	2.95	1.85	1.47	1.17	0.92
30			11.18	7.03	4.42	2.78	2.21	1.75	1.39
40				9.38	5.90	3.71	2.94	2.33	1.85
50					7.37	4.64	3.68	2.92	2.31
60						5.56	4.41	3.50	2.77

Ex: A two-wire 20-ampere circuit using 12 AWG with a one-way distance of 25 feet will drop 1.98 volts;
 120 volts - 1.98 volts = 118.02 volts as the load voltage.
 230 volts - 1.98 volts = 228.02 volts as the load voltage.
 240 volts - 1.98 volts = 238.02 volts as the load voltage.

Caution: Operating unit with less than required voltage or inadequate generator size will result in damage to electrical components. This machine is marked with the correct input voltage on input cords located on bottom of the Main Control Panel. **Note:** Agitator motor and blower(s) should only be operated with steady or constant flow of electricity. **Do not** operate machine with less than required voltage. Damage to motors and other electrical parts will result. Check voltmeter on Main Control Panel when machine is running. **Note:** The plugs that were supplied with the machine will need replaced when using portable power. See instructions below.

- a. **For 120volt, 60hz. models only**, replace the 30 amp plug that was supplied on the machine with the 50 amp plug that was included as an option. Then take the 30 amp plug that was just removed and change it out with the 20 amp plug, thus indicating using 2 separate circuits.
- b. **For 240volt, 60hz. models only**, replace the 30 amp plug that was supplied on the machine with the 50 amp plug that is provided, thus indicating using 1 single circuit.

Machine Hook-up (cont.)

2. For 120volt, 60hz. models only, properly connect female receptacle to extension cord. See Illustration D and consult electrician for assistance.

Electrical Hook-up for 120volt, 60hz.

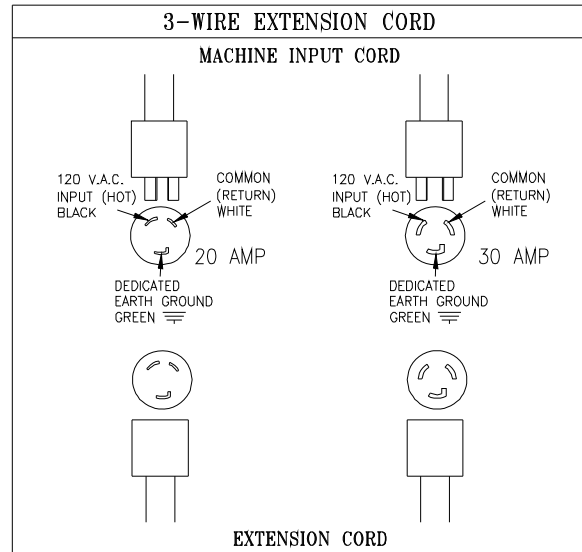

(Illustration D)

3. For 240volt, 60hz. models only, properly connect female receptacle to extension cord. See Illustration D -1 and consult electrician for assistance.

Electrical Hook-up for 240volt, 60hz.

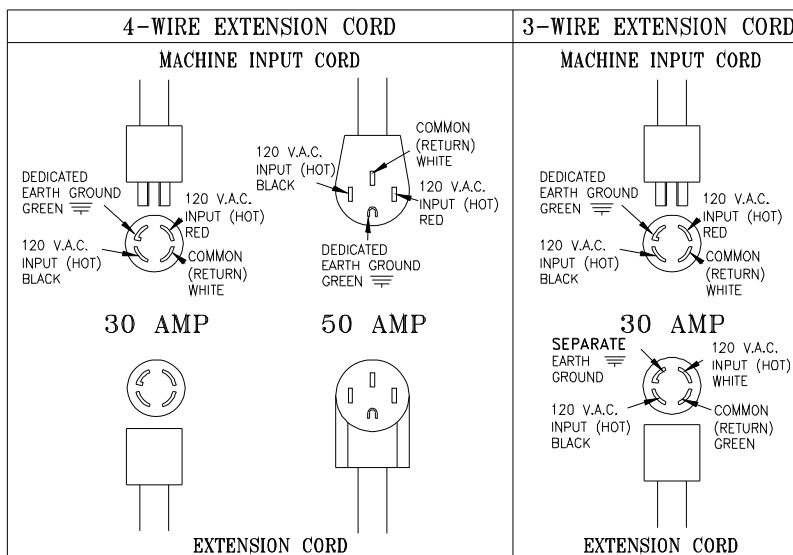

(Illustration D-1)

IMPORTANT NOTE FOR 3-WIRE CORD:

A **separate** isolated ground is required that connects the frame of the machine to an earth ground source. Serious injury or death may result if machine is **not** properly grounded. If you have any further questions, consult a qualified electrician.

Electrical Operation

PRESS KILL SWITCH TO IMMEDIATELY STOP MACHINE AT ANY TIME!

1. Make sure Kill Switch is out by pulling. (See Illustration E)
2. Turn *red* Main Disconnect Switch to ON position. (See Illustration E)
3. Set 4-Position Selector Switch to OFF. (See Illustration E)
4. Press *green* start Button. **Machine will not run unless start button is pressed after Kill Switch is out and red Main Disconnect Switch is on.** (See Illustration E)
5. Select operating mode on 4-Position Selector Switch from one of the following options:

- Remote:** Remote control hand pendant will control machine.
- Off:** Machine will not run. (overrides remote hand pendant)
- Blower:** Only the blower will run continuously. (manual control at machine)
- Agitator-Feed/Blower:** Both the blower and the agitator-feed will run continuously. (manual control at machine)

Main Control Panel (lid closed)

(Illustration E)

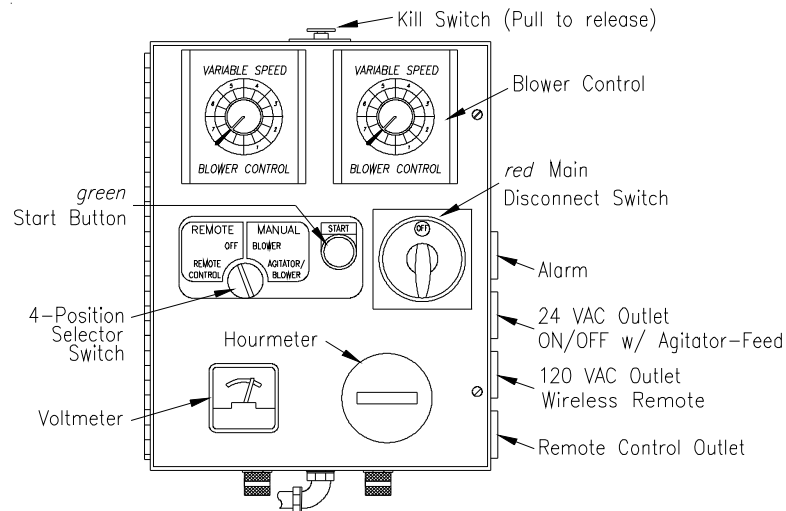

6. When operating in **Remote mode**, the 4-Position Selector Switch must be set to **Remote** position. (See Illustration E)
7. Remote control hand pendant positions will be selected from the following:

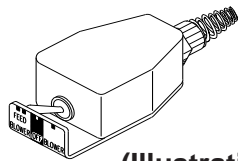

(Illustration F)

- BLOWER-FEED** - operates both **blower motor** and **agitator-feed motor** simultaneously
- OFF** - (middle position) all functions stop
- BLOWER** - operates the **blower motor** only

8. If using optional Internal Wetting System (IWS), connect IWS cord to 24 VAC Outlet on Main Control Panel.
9. Adjust blower(s) and slidegate to desired settings. (See page 14 and 15)
10. **To adjust alarm time**, follow the procedure below: (See Illustration G)

- a) Unplug machine from power source.
- b) Turn **off** *red* Main Disconnect Switch, loosen two screws in door, and open Main Control Panel lid.
- c) Turn Timer Relay knob to desired setting. (clockwise to **increase** warning time)
- d) Close lid, tighten two screws in door, plug in machine, turn on *red* Main Disconnect Switch and press *green* Start Button.
- e) Retest machine.

Main Control Panel (lid open)

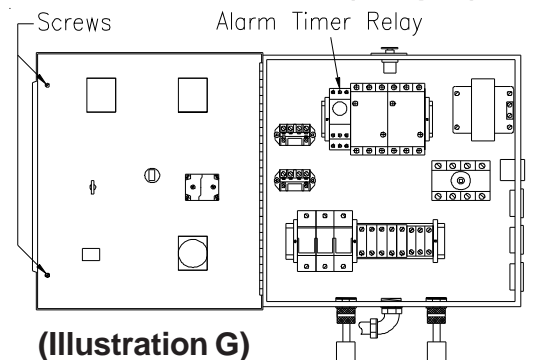

(Illustration G)

Mechanical Settings

Your machine contains blower and slidegate controls used to adjust your machine for each application and type of insulation. (See Illustration H for machine model and location of controls) **Blower control** (air) and **slidegate** (material feed) are adjusted according to:

- Application:** Open blow, retro-sidewall and spray-on applications require varying amounts of control.
- Type of Material:** Cellulose, fiberglass, and mineral fiber have different textures and densities that respond to machine settings.
- Hose:** Corrugations or roughness of interior surface, diameter, length and elevation of hose will also require varying adjustments.
- Weather Conditions:** Temperature and humidity may require day to day adjustment of machine settings.

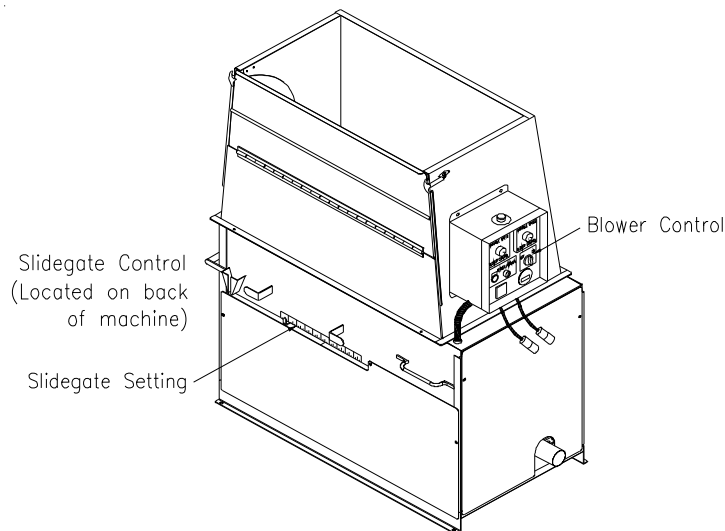

(Illustration H)

BLOWER CONTROL AND SLIDEGATE GENERAL SETTINGS:

Blower control can increase or decrease the amount of air in the system, affecting the velocity (speed) and spread rate (coverage) of insulation. (See Illustration H) The blower control dial operates clockwise, from HIGH to LOW, controlling air pressure and amount of air.

Opening or closing slidegate (material feed) controls the amount of insulation dropping into the airlock which changes the production rate (lbs. per hour). (See Illustration H) For calibration purposes the scale located on right side of machine indicates how many inches the airlock slidegate is opened.

The blower and slidegate controls **working together** affect the distance insulation can be blown through a hose without plugging. These controls also affect the accurate blowing of insulation for spraying applications.

These settings control the following:

- **Density** of insulation blown in retro-sidewall application.
- **Velocity** of material impact when spraying.
- **Dust** on open blow.
- Material **spread rate** or coverage.
- **Production** rate (lbs. per hour blown).

Mechanical Settings (cont.)

GENERAL BLOWER CONTROL AND SLIDEGATE SETTINGS FOR OPEN BLOW: (See Illustration H)
 With the **slidegate** closed, turn **agitator-feed motor on** and variable speed blower control(s) on low. Fill hopper with insulation and adjust **blower control** and **slidegate**. In making adjustments, move controls proportional to each other. (i.e. If variable speed **blower control** is half speed, **slidegate** should be half open.) Open slidegate to allow insulation to drop into the airlock providing good production, but not beyond point where hose plugs. As hose length is increased, the **blower control** speed is increased while closing the slidegate proportionally. This will increase the distance insulation can be blown through the hose and improve material coverage rate, while decreasing the blowing production rate (lbs. per hour blown). These adjustments are for open blow. If specialty application or retro sidewall work is done, refer to General Blower/Slidegate Settings chart (below left) or insulation manufacturer.

GENERAL BLOWER/SLIDEGATE SETTINGS:

Since specific settings need to be determined by each operator, the following are only suggested guidelines. Consult the insulation manufacturer for additional recommendations specific to **their** product.

APPLICATION	BLOWER CONTROL	SLIDEGATE
Open Blow	High	Full Open
Sidewall-Retrofit	Low-Med	1/3 Open -Half Open
Wall Cavity Spray	Medium	Half Open
Commercial Spray (Adhesive)	High	One-third Open

SHREDDER ASSEMBLY:

This unit is supplied with a shredder assembly; airlock/agitator speeds are preset at the factory. **No** further sprocket setting speeds are needed, as this system will accommodate most fibers and applications. However, the shredder **direction** can be adjusted as described below.

SHREDDER ADJUSTMENT:

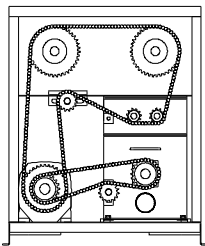

(Illustration I)

Unidirectional Rotation (See illustration I) is preferred as an all-around setting for a combination of materials and applications. This setting provides for the greatest **coverage** and **best control** of the fibers in wall cavity spray, commercial spray, internal wetting (stabilized) and open blow applications.

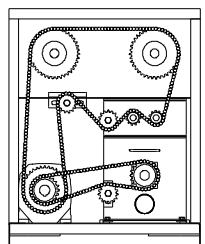

(Illustration J)

Center-Down Rotation (See illustration J) force feeds the insulation into the airlock at a faster rate. This direction is preferred for the greatest **production** of various insulation in an open attic blow application although coverage may decrease. This setting will provide ample coverage and good control of the insulation in wall cavity spray, commercial spray, internal wetting (stabilized) and open blow applications.

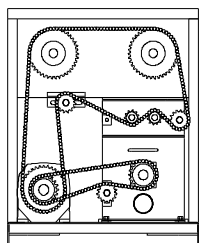

(Illustration K)

Center-Up Rotation (See illustration K) is preferred for extended **coverage** on mineral fiber. **Note: For this application an upgrade kit will be needed.**

GENERAL MAINTENANCE

Periodic preventive maintenance will add years of life to your equipment. Reviewing the information in this manual will go a long way in reducing downtime and lost income.

! KEEP CLEAN: During operation, keep material from accumulating on Blower Filter. Always keep Filter in place while operating machine. After each use, remove fiber from hopper and blow out hose. (Use BLOWER mode at Main Control Panel or Hand Pendant.) Clean air from insulation hose can then be used to blow insulation from agitator motor and Blower Filter area. The *Blower Door* attached to this unit reduces filter maintenance. (See Illustration A on page 8)

Airlock: (Seal Replacement)

The purpose of the airlock seal is to trap air and insulation until it rotates 180° to the 6:00 o'clock position. At this point, insulation is pushed by air from the blower, out of the chamber. Worn or damaged seals allow air and insulation to escape back into hopper, thus reducing production and coverage. When it is necessary to replace seals, follow these directions:

Disconnect power from unit!! Remove hose from input of airlock, remove chain on output. Using a 5/8" socket, remove hold down bolts from airlock. Lower the front of the airlock down by loosening the jamb nuts and turning the liftbolts counterclockwise. Slide the airlock out of the machine. (See illustration L) Airlock rotor plates that are damaged (bent) will need replaced. (Refer to Rotor Plate Replacement on next page.) Take out rubber seal by removing fastening bolts, nuts and top plate. The base plate will remain attached to airlock shaft. To install a new seal, reverse procedure. Seal should be inserted tight against the back base plate, pressing the lower tabs of the seal down under the adjacent seal with a flat blade screwdriver. Make sure all bolt holes are aligned while each side of seal is equally pressed against the end plates, before tightening bolts. Seal should be bent forwards for **counterclockwise** rotation. (See Illustration N on page 17)

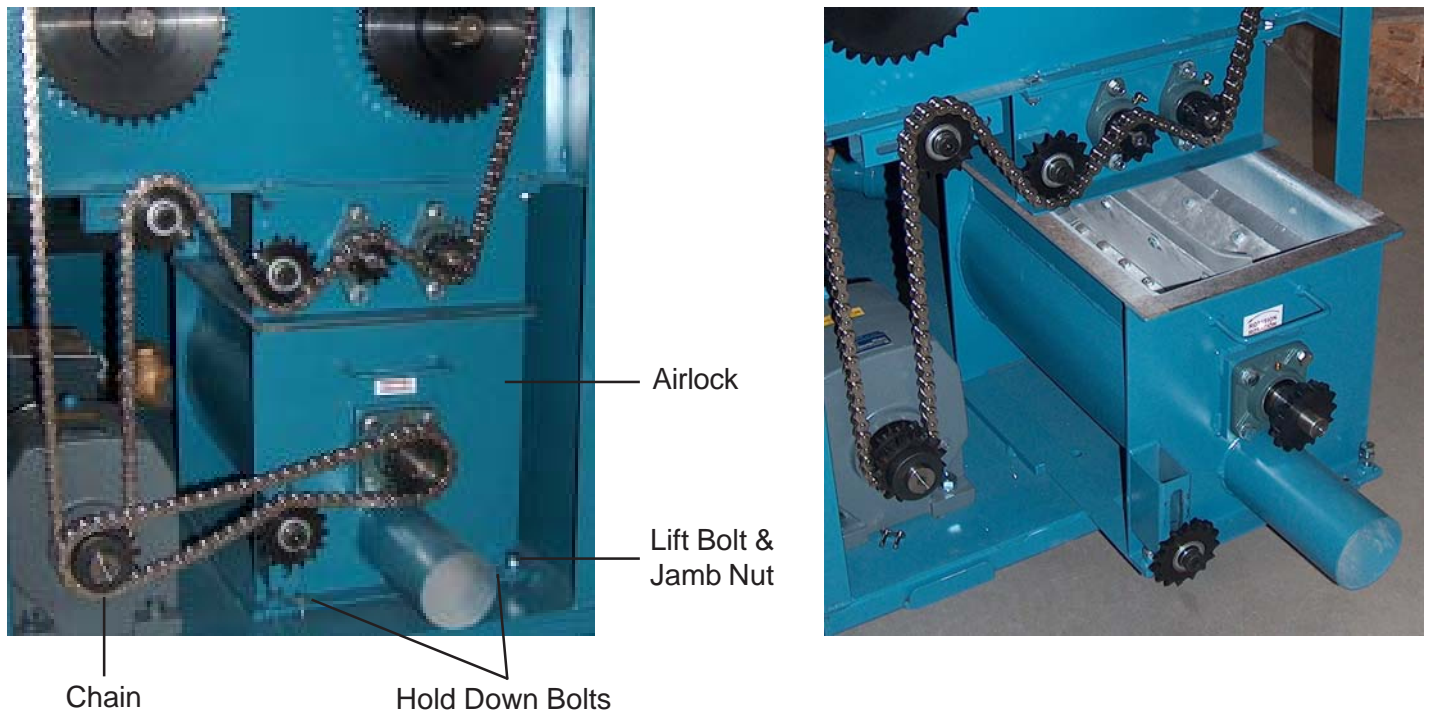

(Illustration L)

General Maintenance (cont.)

BASE PLATE REPLACEMENT:

1. Remove damaged baseplate assembly from shaft using ratchet drive wrench with extension and 1/2" socket.
2. Check seal for wear and damage. (Installing seal and top plate on the bench is quick and easy). Remove bolts from plate assembly and replace with new seal. Make sure seal and top plate are assembled on **correct** side of base plate before assembling in airlock. Seal should press backward towards top plate when installed correctly into airlock chamber. (Illustration N)
3. Install the rotor plate assembly into the airlock. The airlock runs **counterclockwise** viewing it from the sprocket drive shaft. (Illustration N) Align the base plate with holes on airlock shaft using a tapered punch. **Caution:** Do not mount rotor plate backwards. If installed improperly, damage to seals will result and put undue stress on agitator motor. This causes overheating and poor production. Seal should be bent forwards to allow for a **counterclockwise** rotation of rotor.
4. As rotor plate is installed, press bottom tab of seal under adjacent seal with flat blade screwdriver. (See Illustration N) **Note: Entire rotor plate assembly may be removed and replaced. This procedure maybe easier than replacing just the seals.**

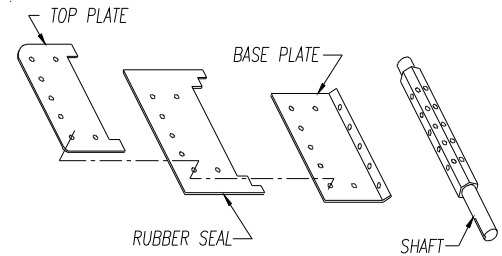

(Illustration M)

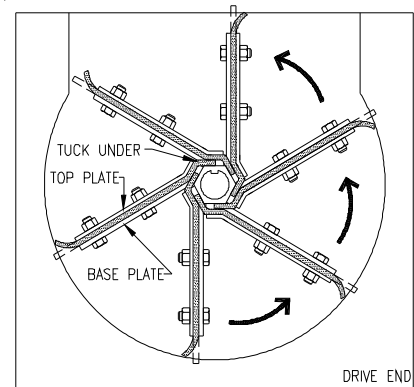

(Illustration N)

CHAIN: (#50 Nickel Plated)

ADJUSTMENT: A smooth operating chain drive should have a slight sag on the idler side of the chain. New chains should be installed under slight tension as they will elongate a small amount due to seating of pins and bushings during the first few days of operation. Chain should be kept in good condition by proper lubrication (dry film lubricant Dow 321) and occasional cleaning. Soaking chain in container of 10 weight oil will provide for internal lubrication of pins and bushings. However, excess oil must be drained and wiped away as excessive lubrication will cause insulation accumulation on chain. Worn out chain should be replaced. When chain is replaced, worn sprockets should also be replaced, preventing further damage to new chain.

SPROCKETS:

CHECK SPROCKETS FOR WEAR. Misalignment and/or loose sprockets and improper chain tension causes the premature wear of chain and sprockets. All sprockets, except speed reducer and idler sprockets, have been secured with a medium grade Loctite (general purpose thread locker), to prevent gradual movement. The set screws and key are also inserted with a medium grade Loctite. If sprocket is difficult to remove, it may be heated with a propane torch to loosen.



Caution: Do not overheat sprocket or damage to bearing will result. A pulley or bearing puller can then be used to remove the sprocket and key. Replace new sprocket on shaft with key and medium grade Loctite applied to shaft. Align sprocket with corresponding sprocket, using a straightedge placed along face of teeth and tighten set screw. Speed reducer sprocket does **not** require Loctite.

General Maintenance (cont.)

BEARINGS:

BEARING REPLACEMENT: Spray area with rust penetrant (WD-40). Remove sprocket (See SPROCKET section on page 17). Remove four bolts from airlock bearing flange (two bolts from shredder bearing flange) Loosen set screws on bearing hub at each end of agitator shaft. Since all set screws are installed with a medium grade Loctite, a propane hand torch may be used to assist in removing them. Do not overheat unit, causing shaft to expand. Using a rubber mallet, drive agitator shaft an inch in one direction, creating a space between hopper and bearing unit. A bearing puller can then be used to remove the bearing. Eliminate any metal burrs from shaft with file and install new bearings with felt seals. Use a medium grade Loctite on set screws before securing bearing to shaft. (Check shaft diameter before ordering bearings; 3/4" or 1")

AGITATOR, AIRLOCK AND SHREDDER BEARINGS are prelubricated, double sealed, self aligning ball bearings. Lubrication is required at three month intervals of normal running time, or sooner if bearings produce a noise or become too-hot-to-touch. Relubrication at the grease fittings is done with a lithium base grease conforming to a NLGI GRADE TWO consistency. The grease should be pumped in slowly until a slight bead forms around the seals. This bead, in addition to acting as an indicator of adequate lubrication, provides additional protection against the entry of foreign matter. **Important:** If a slight bead does **not** form indicating a failure of lubrication or if bearing shows signs of wear, replace bearing.

SPEED REDUCER:

Periodically check oil level in reducer. Do not lay machine on its side as lubricant from unit will drain from vent plug. If speed reducer malfunctions because of improper oil level or type used, **warranty is voided**. Oil seals at input and output drives are considered to be replaceable maintenance items and can affect oil level. These are available at power transmission distributors. Your speed reducer has been filled with a synthetic lubricant (Klubersynth UH1 6-460). Consult speed reducer manufacturer's manual for lubricant replacement intervals.

LUBRICATION: This speed reducer was filled with oil at the factory to operate within -30°F to +225°F ambient temperature. After 1500 hours of operation, drain and refill with Klubersynth UH1 6-460 gear oil. If Klubersynth UH1 6-460 gear oil is not available, use multipurpose gear oil SAE #90 for ambient temperatures from +40°F to +120°F. For temperatures below +40°F use SAE #80 multipurpose gear oil. Correct oil level for mounted unit is just below pipe plug (C on illustration O) in side position.

LUBRICANT REPLACEMENT: (See Illustration O)

1. Drain: With output shaft of speed reducer facing you, remove plug (A) with 1/4" hex key wrench. Allow unit to completely drain and replace plug.
2. Remove vent plug (B) on reducer, and plug (C) on right side.
3. Fill with recommended lubricant (use Klubersynth UH1 6-460 gear oil) through vent plug (B) opening, using a flexible funnel, until lubricant exits the left side opening (C). (Make sure speed reducer is level when replacing lubricant.)
4. Replace vent plug (B) and right plug (C).

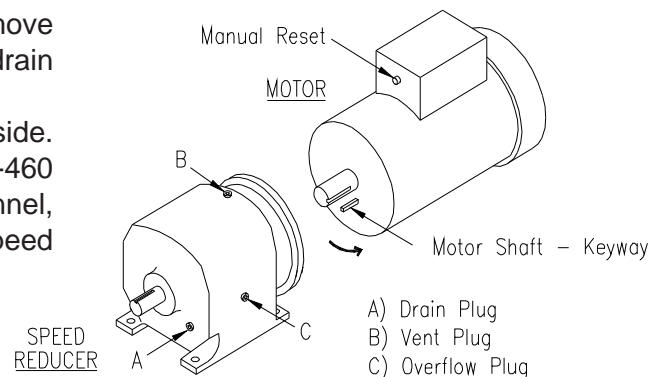

(Illustration O)

General Maintenance (cont.)

AGITATOR MOTOR:

If agitator motor runs hot, unit may shut off. Wait for motor to cool, then activate the manual reset on motor by depressing button. (See Illustration O) If unit does not run properly, refer to troubleshooting sections of manual. The agitator motor should start quickly and run smoothly. If not, shut motor off **immediately** and check the cause. Low voltage, incorrect power supply, bad bearings, or misconnected wiring could cause motor failure. **These conditions void the motor warranty.** Overload conditions can be detected by checking the electrical current (amperage) compared with nameplate current (amperage) located on the body of the motor.

AGITATOR MOTOR REPLACEMENT: Disconnect power from unit!!! Unwire motor from Main Control Panel and remove drive chain. Place a support block under motor to reduce stress while removing four reducer flange bolts with a 9/16" socket wrench. (If rear bolts are difficult to reach, remove reducer unit from lower frame for better access.) Pry motor from speed reducer a slight distance, using a large flat blade screwdriver placed in one of the slots where they join together. Pull motor unit straight away from speed reducer, retaining key. If motor does not separate easily, contact factory for assistance. (See Illustration O on page 18) Before installing replacement motor, refer to motor nameplate. Check connection of new cord for correct voltage (low or high) and **PROPER ROTATION** of **speed reducer** output shaft. **Note: Refer to motor nameplate and interchange rotation wire leads to obtain counterclockwise rotation on speed reducer output shaft.** Rotate keyways of motor shaft and quill (input) of speed reducer to 12:00 o'clock position. (To turn speed reducer shaft, remove chain on output of speed reducer.) Assemble the key 3/4" off the end of the motor shaft and coat motor shaft with anti-seize compound. Align and insert the motor shaft carefully into the input quill. (A flat blade screwdriver may be helpful to keep key in place as motor shaft is inserted or centerpunch motor shaft.) Secure to flange with four hex bolts.

Caution: If the motor does not readily seat itself, check to determine if **key** has moved axially along motor shaft, causing interference. Tightening motor to reducer with excessive pressure against key will cause premature bearing failure and overheating of motor and reducer. Connect motor to Main Control Panel and check for correct rotation of **speed reducer** output shaft (**counterclockwise**). Reconnect drive chain and assemble unit for manual operation.

BLOWER MOTOR:

Periodically remove Blower Filter and vacuum any material that has accumulated inside of blower box and around blower motor. Blow out any remaining debris around motor and intake orifice of fan with compressed air. This will extend the life of the blower significantly. Blower Filter life can be extended by occasional removing and back or reverse blowing through with compressed air. Filter should be replaced periodically depending on use. If blower produces noise or heat, refer to troubleshooting section of manual.

BLOWER REPLACEMENT: Disconnect power from unit!!! Remove Blower Door. (See Illustration P) Take note of electrical connections on blower and remove wire nuts from lead wires. Loosen hose clamp at the rear of the blower. Remove blower bracket assembly, secured with bolt, from blower box. Remove three bolts and spacers from blower bracket and remove blower. Reverse procedure for assembly. **NOTE: DO NOT OVER TIGHTEN BOLTS ON RE-ASSEMBLY, IT MAY DAMAGE BLOWERS AND VOID WARRANTY!!**

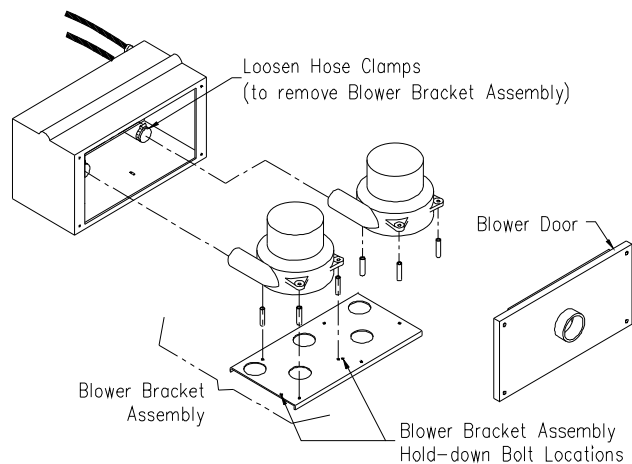

Double 12.5 AMP (6 Amp 230 volt) 3-Stage Blower

(Illustration P)

General Maintenance (cont.)

CARBON BRUSH REPLACEMENT for 12.5 AMP (6 AMP 230 volt) 3-STAGE BLOWER: (See Illustration Q)

Order replacement brushes from your supplier to assure proper brush style. Carbon brushes need to be replaced when excessive arcing is produced on the commutator. This would be evident by an intermittent scratchy sound with loss of blower r.p.m. Replace brushes before brush shunt touches the commutator.

1. Remove Blower from Blower Box. (See Blower Replacement on page 19)
2. Remove screw and shield from blower. (See Illustration Q)
3. Unhook wire connected to Brush Assembly.
4. Remove Brush Cover screws by inserting screwdriver through hole in blower housing and turning screw.
5. Pull out old Brush Assembly and install new Brush Assembly and Brush Cover.
6. Connect wire to Brush Assembly and reassemble blower shield. On reassembly and handling, the lead wires must be kept away from rotating parts and motor frame.
7. To achieve best performance, the new brushes should be seated on the commutator before full voltage is applied. To seat brushes, run variable speed blower control on medium speed for thirty minutes after brush change. The motor will return to full performance after an additional thirty to forty-five minutes running period at full voltage (BLOWER CONTROL on high). Application of full voltage directly after changing brushes will cause arcing, commutator pitting, and reduced overall life. Brushes can normally be changed two times before armature and other component replacement is required.
8. Reinstall Blower into Blower Box and wire Blower to Main Control Panel.

(Illustration Q)
12.5 AMP (6 Amp 230 volt)
3-Stage Blower Motor
(Brush Replacement)

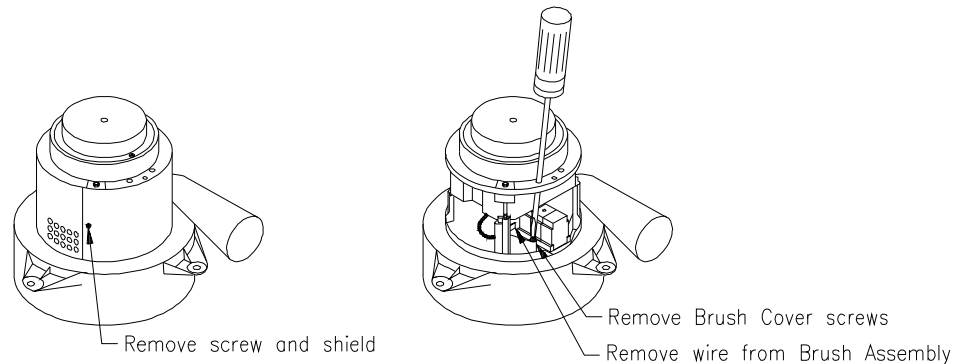

Note: The 14.5 AMP 2-Stage blower motor does not have carbon brush replacement due to the extended brush life.

ELECTRICAL SYSTEM

General Operation: (See Illustration R for sequence and Illustration E, S, T, U, V, W and X for components) This unit is powered by **one** or **two** separate input sources connected at the bottom of the Main Panel Box. Turning the Main Disconnect Switch (*yellow* and *red* switch located on front of Main Control Panel) to the ON position distributes power to the Terminal Boards of the Main Control Panel, Voltmeter, Kill Switch, and the Upper Terminals of the agitator (C4) and the blower (C5) relays. (See illustration E)

When the Kill Switch (*red* mushroom button) is released (closed) and the *green* Start Button is pressed, power is supplied to the dropout relay(s) and the transformer. The transformer supplies 24 VAC to the 4-Position Selector Switch located on the front of the Main Panel Box.

When the 4-Position Selector Switch is turned to MANUAL mode or the 4-Position Selector Switch is set to REMOTE mode with remote control hand pendant switch closed, 24 VAC is supplied to the Pre-Alarm relay, sounding the alarm for a preset time. After the alarm stops, 24 VAC powers the blower (C5) and/or agitator (C4) relays.

When the agitator (C4) relay is closed, power is also supplied to the 24 VAC ON/OFF Outlet on Main Control Panel. If power is interrupted to this system by unplugging either main input cord(s), turning Main Disconnect Switch OFF, or pressing Kill Switch; the *green* Start Button needs to be **pressed** to reactivate the system **after** power distribution into the system has been reestablished. (See illustrations S, T, U, V, & W for more details.)

**Electrical Flowchart
(Illustration R)**

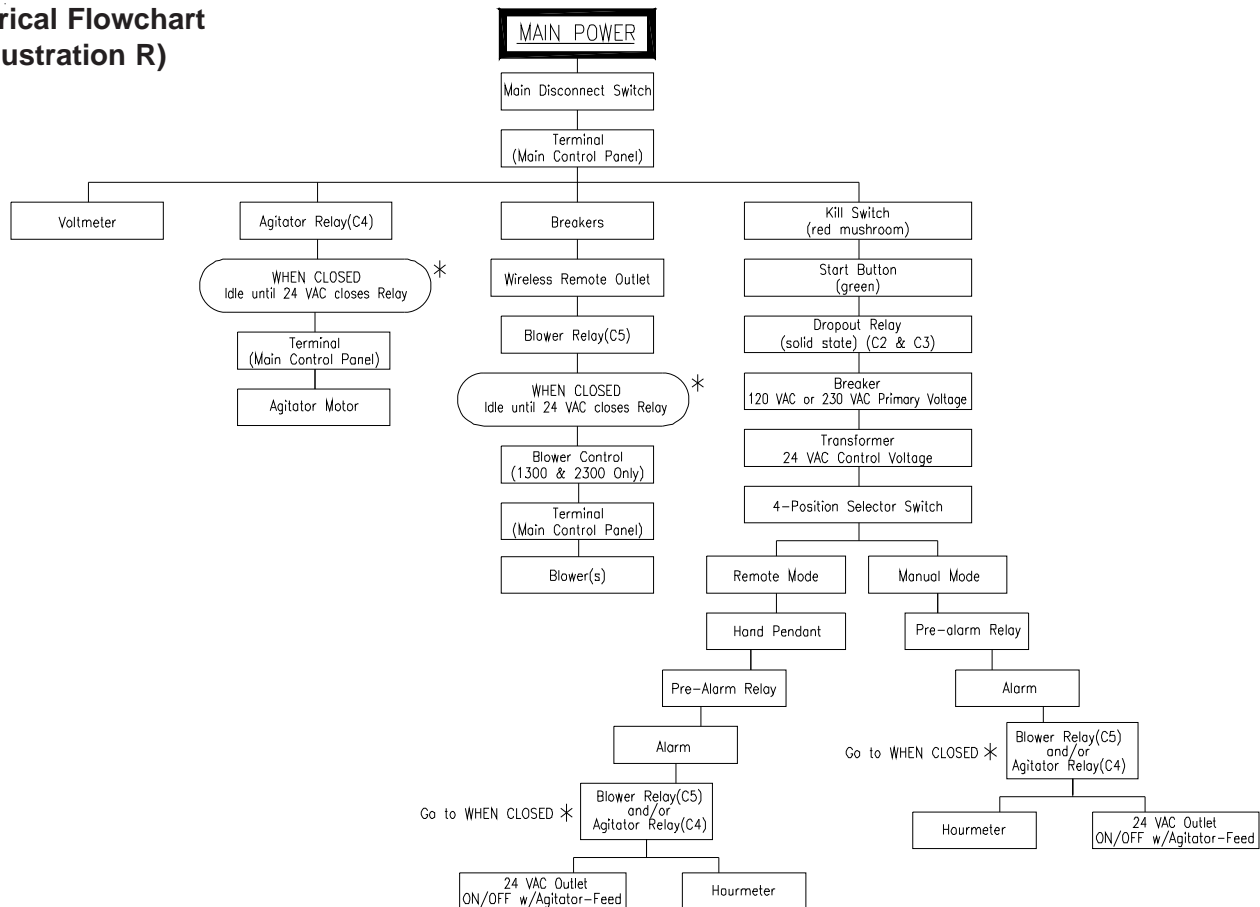

Electrical System (cont.)**Electrical Diagram Description for Pages 23-28:**

Tags have been placed at the end of each wire in the electrical system to identify specific wires. This identification code is as follows:

- First letter - identifies component classification
- Second number - indicates specific component
- Decimal number/letter - identifies the terminal on the component

Letter next to identification code indicates **color code**.

Second series of numbers and letters **after dash** which identify connection at opposite end of wire are as follows:

- First letter - identifies component classification
- Second number - indicates specific component
- Decimal number/letter - identifies the terminal on the component

Example: R1.8-4SBL.1

Wire is connected between relay #1, terminal 8 and Four Position Selector Switch bottom left, terminal 1.

LEGENDS FOR ELECTRICAL DIAGRAMElectrical Component Abbreviations

- TF = Transformer (.H1, .H4, .X1, .X2)
- C = Relay (C1,C2,C3,etc.)
- D = Disconnect Switch (.L = Disconnect input Line, .T = Disconnect output Terminal)
- BK = Breaker (BK1,BK2,etc.)
- T = Terminal Board for Main Control Panel
- I = Input Cord
- RI = Right Input Cord (for Blower)
- LI = Left Input Cord (for Agitator)
- O = Outlet (O1,O2,O3,O4,etc.)
- V = Voltmeter
- H = Hand Pendant
- A = Alarm
- K = Kill Switch
- B = Blower (B1, B2, etc.)
- 4S = Four Position Selector Switch
- SB = Start Button
- 4SBL = Four Position Selector Switch Bottom Left
- 4STL = Four Position Selector Switch Top Left
- 4STR = Four Position Selector Switch Top Right
- 4SBR = Four Position Selector Switch Bottom Right

NOTE: Decimal letters (.L, .N, .H, .X) indicate terminal locations on the component.

ELECTRICAL

ELECTRICAL DIAGRAM:

Periodically, disconnect machine from power source and check all electrical connections and components for broken or loose wires.

MODEL #1300/2300
120 V.A.C. — 60 Hz 1Ø (2 BLOWER)
Double Input
ELU15-109068

(Illustration S)

4-POSITION SELECTOR SWITCH(4S) CONTACT ACTION	BOTTOM		TOP		RIGHT	
	LEFT	RIGHT	LEFT	RIGHT	LEFT	RIGHT
REMOTE	1-1-2	1-1-2	1-1-2	1-1-2	1-1-2	1-1-2
OFF	1-1-2	1-1-2	1-1-2	1-1-2	1-1-2	1-1-2
BLOWER	1-1-2	1-1-2	1-1-2	1-1-2	1-1-2	1-1-2
BLOWER/ AGITATOR	1-1-2	1-1-2	1-1-2	1-1-2	1-1-2	1-1-2

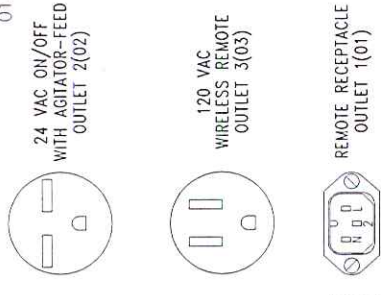
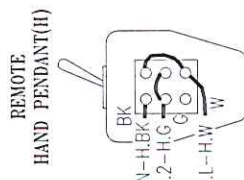

WIRE COLOR CODE

- G = GREEN — Earth Ground
- W = WHITE — Common (120 volt)
- BK = BLACK — Hot (120 volt)
- R = RED — Hot (120 volt)
- Y = YELLOW — Hot (24 volt)
- W/Y = WHITE/YELLOW STRIPE — Common (24 volt)

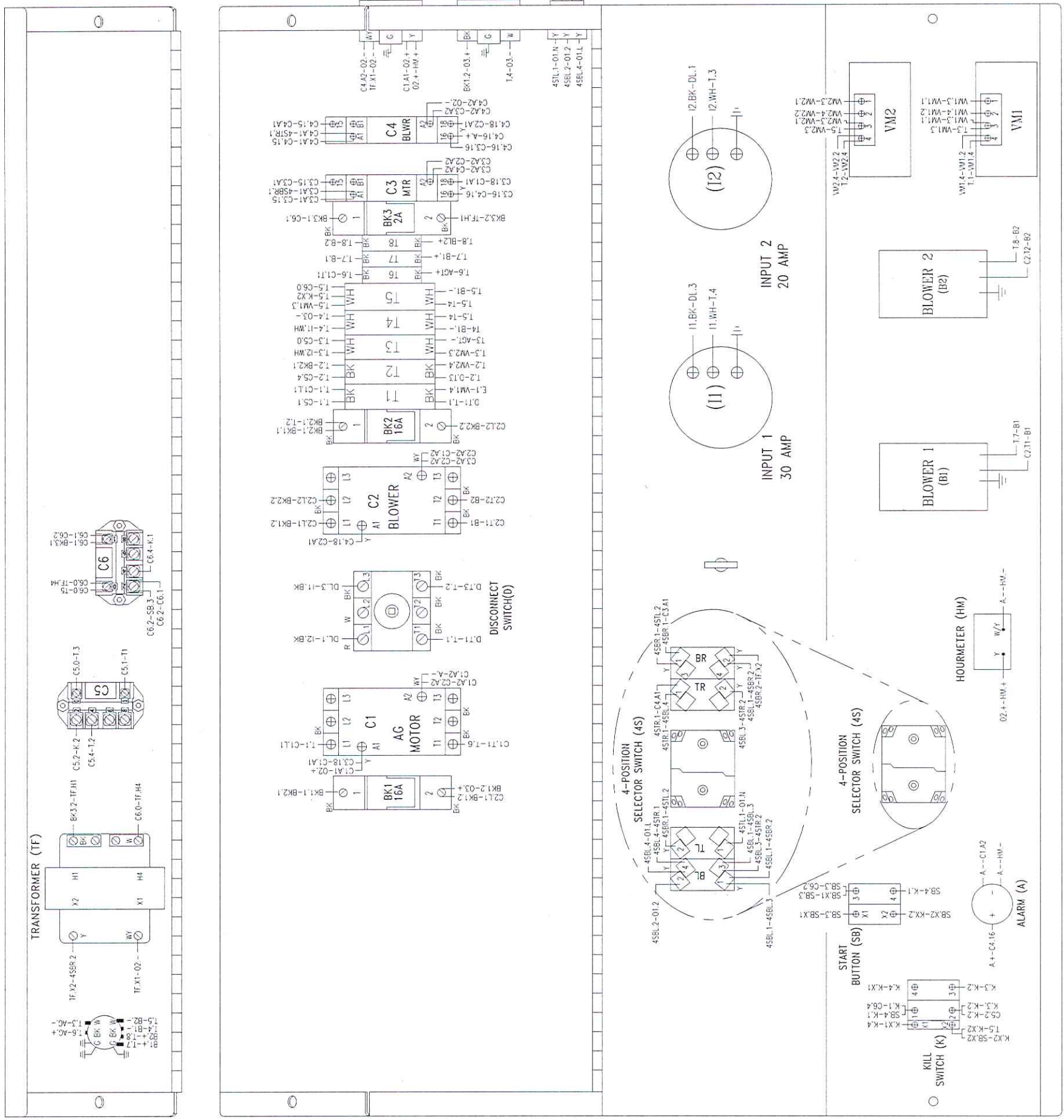

ELECTRICAL DIAGRAM:

Periodically, disconnect machine from power source and check all electrical connections and components for broken or loose wires.

**MODEL #1300/2300
240 V.A.C. — 60 Hz 1Ø
ELU12-109070**

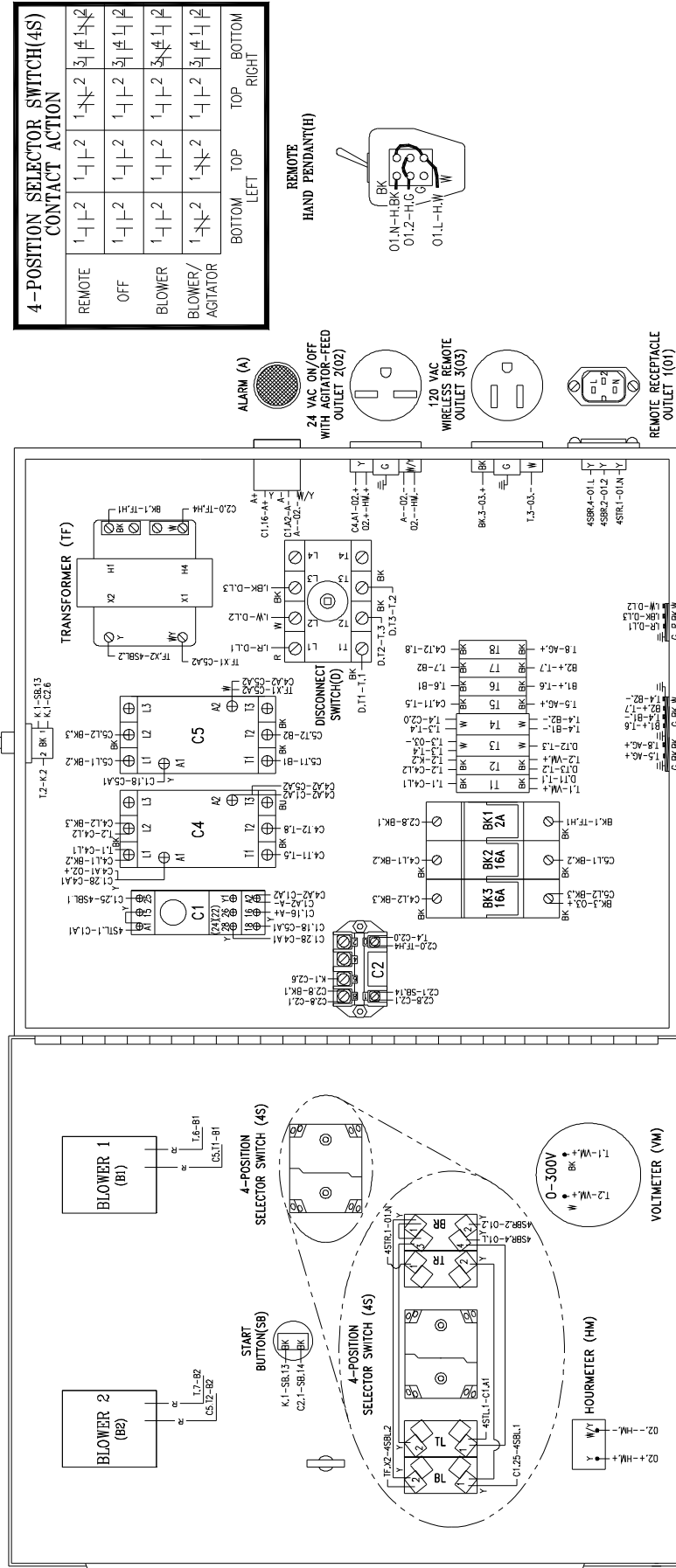

4-POSITION SELECTOR SWITCH(4S) CONTACT ACTION			
REMOTE	1-1-2	1-1-2	1-1-2
OFF	1-1-2	1-1-2	1-1-2
BLOWER	1-1-2	1-1-2	1-1-2
BLOWER/ AGITATOR	1-1-2	1-1-2	1-1-2
	BOTTOM	TOP	RIGHT

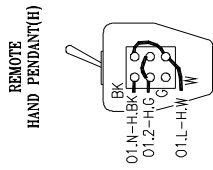

WIRE COLOR CODE

G	=	GREEN	-	Earth Ground
W	=	WHITE	-	Common (120 volt)
BK	=	BLACK	-	Hot (120 volt)
R	=	RED	-	Hot (120 volt)
Y	=	YELLOW	-	Hot (24 volt)
W/Y	=	WHITE/YELLOW STRIPE	-	Common (24 volt)

(Illustration T)

ELECTRICAL DIAGRAM:

Periodically, disconnect machine from power source and check all electrical connections and components for broken or loose wires.

MODEL #1300/2300
240 V.A.C. — 60 Hz 1Ø (4 BLOWER)
Single Input
ELU13-109071

(Illustration U)

4-POSITION SELECTOR SWITCH(4S) CONTACT ACTION	BOTTOM LEFT		TOP LEFT		TOP RIGHT		BOTTOM RIGHT	
	1-1-2	1-1-2	1-1-2	1-1-2	1-1-2	1-1-2	1-1-2	1-1-2
REMOTE	1-1-2	1-1-2	1-1-2	1-1-2	1-1-2	1-1-2	1-1-2	1-1-2
OFF	1-1-2	1-1-2	1-1-2	1-1-2	1-1-2	1-1-2	1-1-2	1-1-2
BLOWER	1-1-2	1-1-2	1-1-2	1-1-2	1-1-2	1-1-2	1-1-2	1-1-2
BLOWER/ AGITATOR	1-1-2	1-1-2	1-1-2	1-1-2	1-1-2	1-1-2	1-1-2	1-1-2

REMOTE
HAND PENDANT(H)

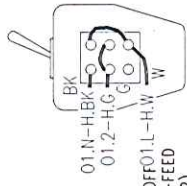

24 VAC ON/OFF(01L-H,W)
WITH AGITATOR-FEED
OUTLET 2(02)

WIRELESS REMOTE
OUTLET 3(03)
120 VAC

REMOTE RECEPTACLE
OUTLET 1(01)

WIRE COLOR CODE

- G = GREEN — Earth Ground
- W = WHITE — Common (120 volt)
- BK = BLACK — Hot (120 volt)
- R = RED — Hot (120 volt)
- Y = YELLOW — Hot (24 volt)
- W/Y = WHITE/YELLOW STRIPE — Common (24 volt)

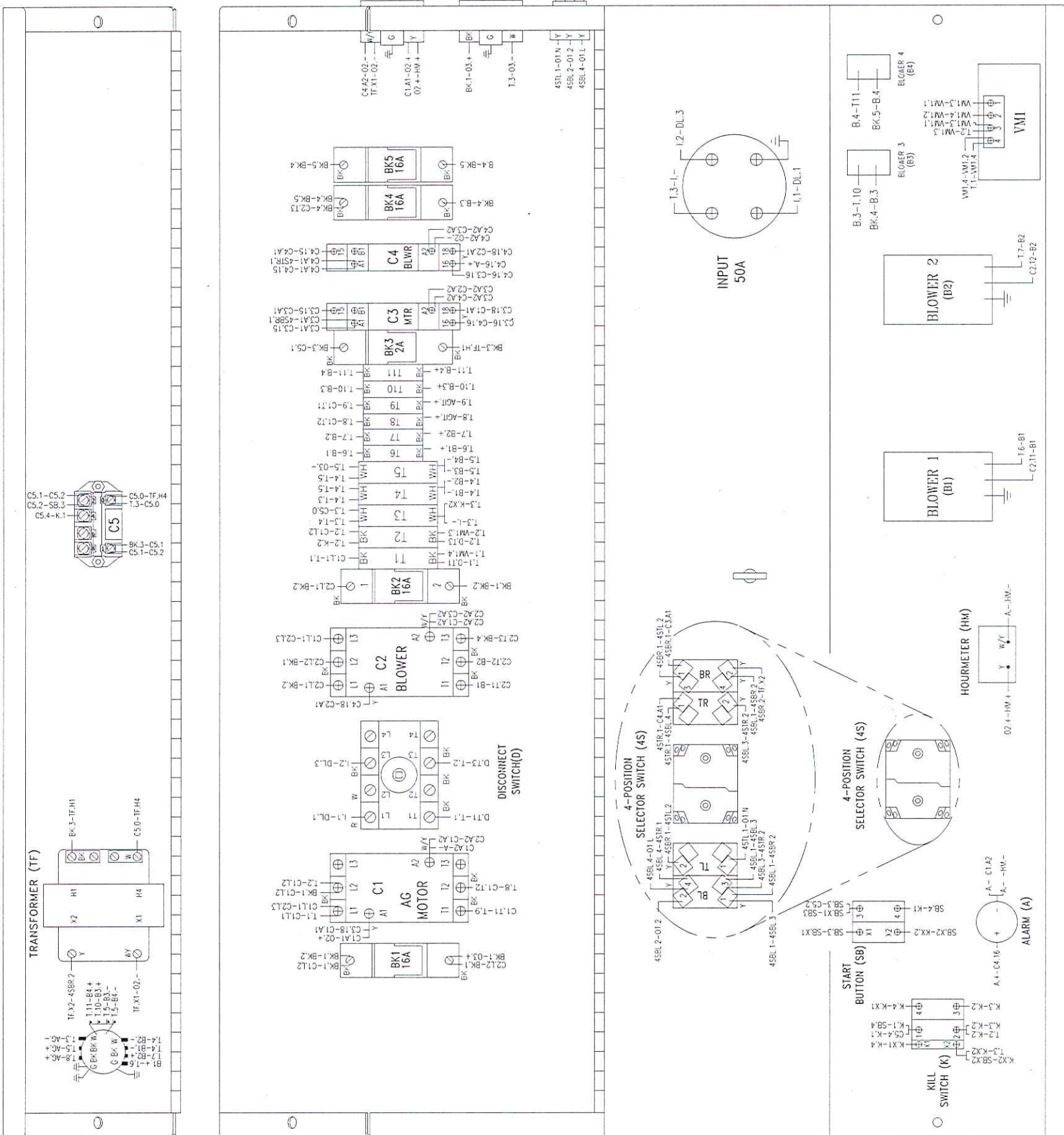

ELECTRICAL DIAGRAM:

Periodically, disconnect machine from power source and check all electrical connections and components for broken or loose wires.

**MODEL #1300/2300
230 V.A.C. — 50 Hz 1Ø
ELU10-109072**

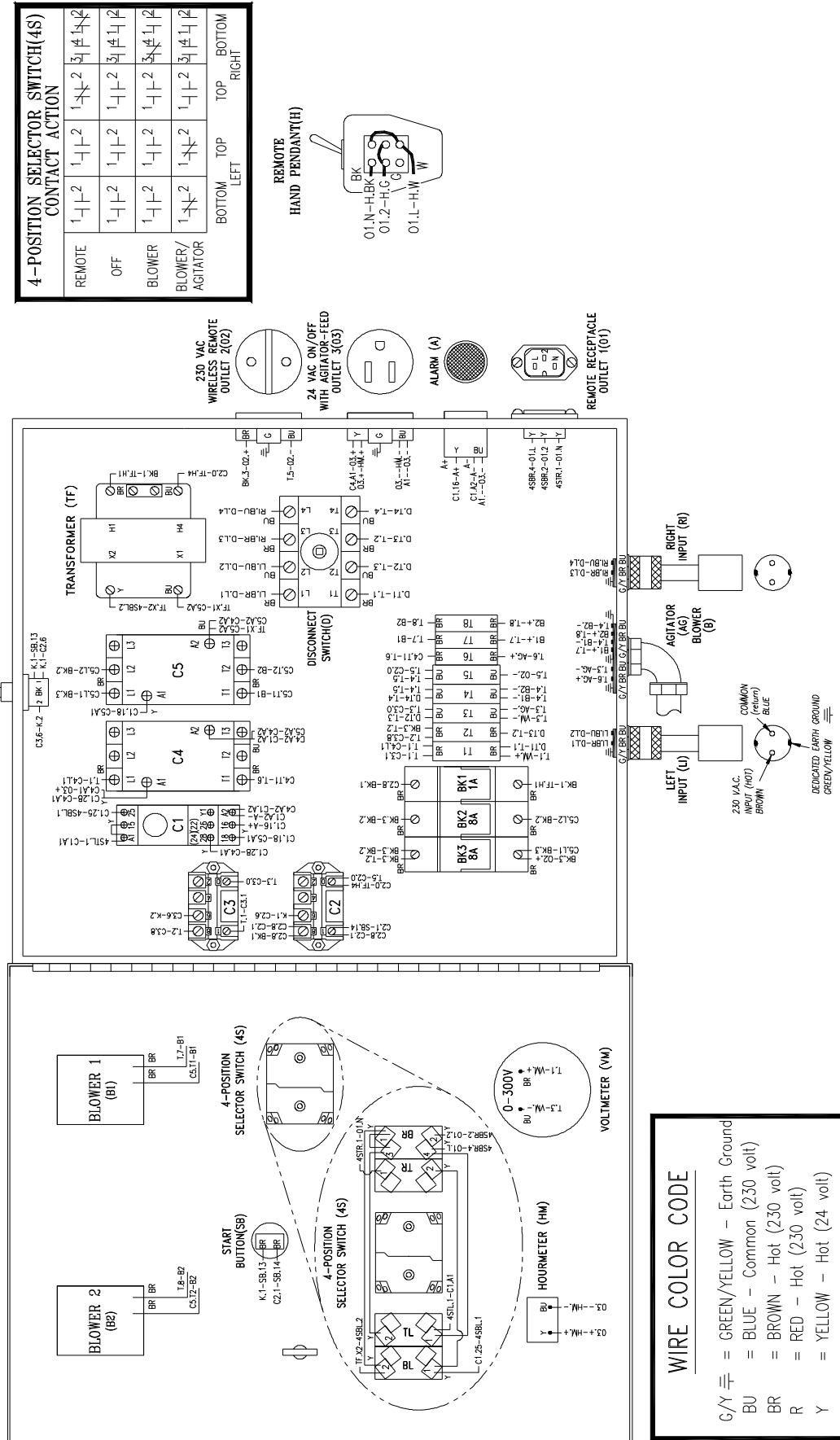

4-POSITION SELECTOR SWITCH(4S) CONTACT ACTION			
REMOTE	1-1-2	1-1-2	1-1-2 1-1-2
OFF	1-1-2	1-1-2	1-1-2 1-1-2
BLOWER	1-1-2	1-1-2	1-1-2 1-1-2
BLOWER/ AGITATOR	1-1-2	1-1-2	1-1-2 1-1-2

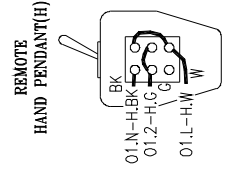

WIRE COLOR CODE

- G/Y = GREEN/YELLOW - Earth Ground
- BU = BLUE - Common (230 volt)
- BR = BROWN - Hot (230 volt)
- R = RED - Hot (230 volt)
- Y = YELLOW - Hot (24 volt)

(Illustration V)

ELECTRICAL DIAGRAM:
Periodically, disconnect machine from power source and check all electrical connections and components for broken or loose wires.

WIRE COLOR CODE	
G/Y	= GREEN/YELLOW - Earth Ground
BU	= BLUE - Common (230 volt)
BR	= BROWN - Hot (230 volt)
R	= RED - Hot (230 volt)
Y	= YELLOW - Hot (24 volt)

MODEL #1300/2300
230 V.A.C. — 50 Hz 1Ø (4 Blower)
ELU11-109073

4-POSITION SELECTOR SWITCH(4S) CONTACT ACTION	BOTTOM		TOP		LEFT		RIGHT	
	1-1-2	1-1-2	1-1-2	1-1-2	1-1-2	1-1-2	1-1-2	1-1-2
REMOTE	1-1-2	1-1-2	1-1-2	1-1-2	1-1-2	1-1-2	1-1-2	1-1-2
OFF	1-1-2	1-1-2	1-1-2	1-1-2	1-1-2	1-1-2	1-1-2	1-1-2
BLOWER	1-1-2	1-1-2	1-1-2	1-1-2	1-1-2	1-1-2	1-1-2	1-1-2
BLOWER/ AGITATOR	1-1-2	1-1-2	1-1-2	1-1-2	1-1-2	1-1-2	1-1-2	1-1-2

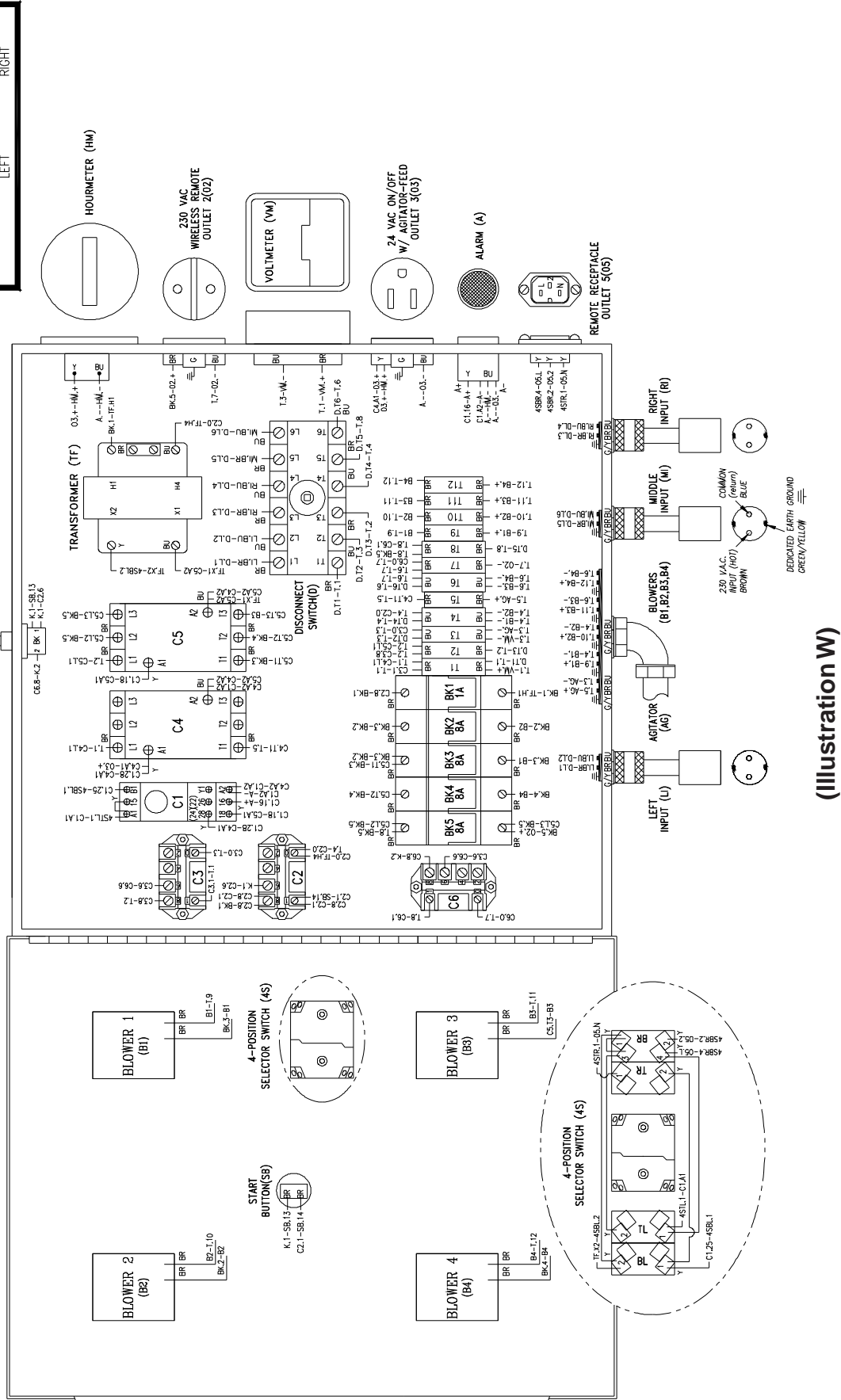

(Illustration W)

ELECTRICAL DIAGRAM:

Periodically, disconnect machine from power source and check all electrical connections and components for broken or loose wires.

WIRE COLOR CODE

- G/Y = GREEN/YELLOW - Earth Ground
- BU = BLUE - Common (230 volt)
- BR = BROWN - Hot (230 volt)
- R = RED - Hot (230 volt)
- Y = YELLOW - Hot (24 volt)

MODEL #1300/2300
230 V.A.C. — 50 Hz 1Ø (4 Blower)
ELU11-109073-10

4-POSITION SELECTOR SWITCH(4S) CONTACT ACTION	BOTTOM		TOP		LEFT		RIGHT	
	1-1-2	1-1-2	1-1-2	1-1-2	1-1-2	1-1-2	1-1-2	1-1-2
REMOTE	1-1-2	1-1-2	1-1-2	1-1-2	1-1-2	1-1-2	1-1-2	1-1-2
OFF	1-1-2	1-1-2	1-1-2	1-1-2	1-1-2	1-1-2	1-1-2	1-1-2
BLOWER	1-1-2	1-1-2	1-1-2	1-1-2	1-1-2	1-1-2	1-1-2	1-1-2
BLOWER/ AGITATOR	1-1-2	1-1-2	1-1-2	1-1-2	1-1-2	1-1-2	1-1-2	1-1-2

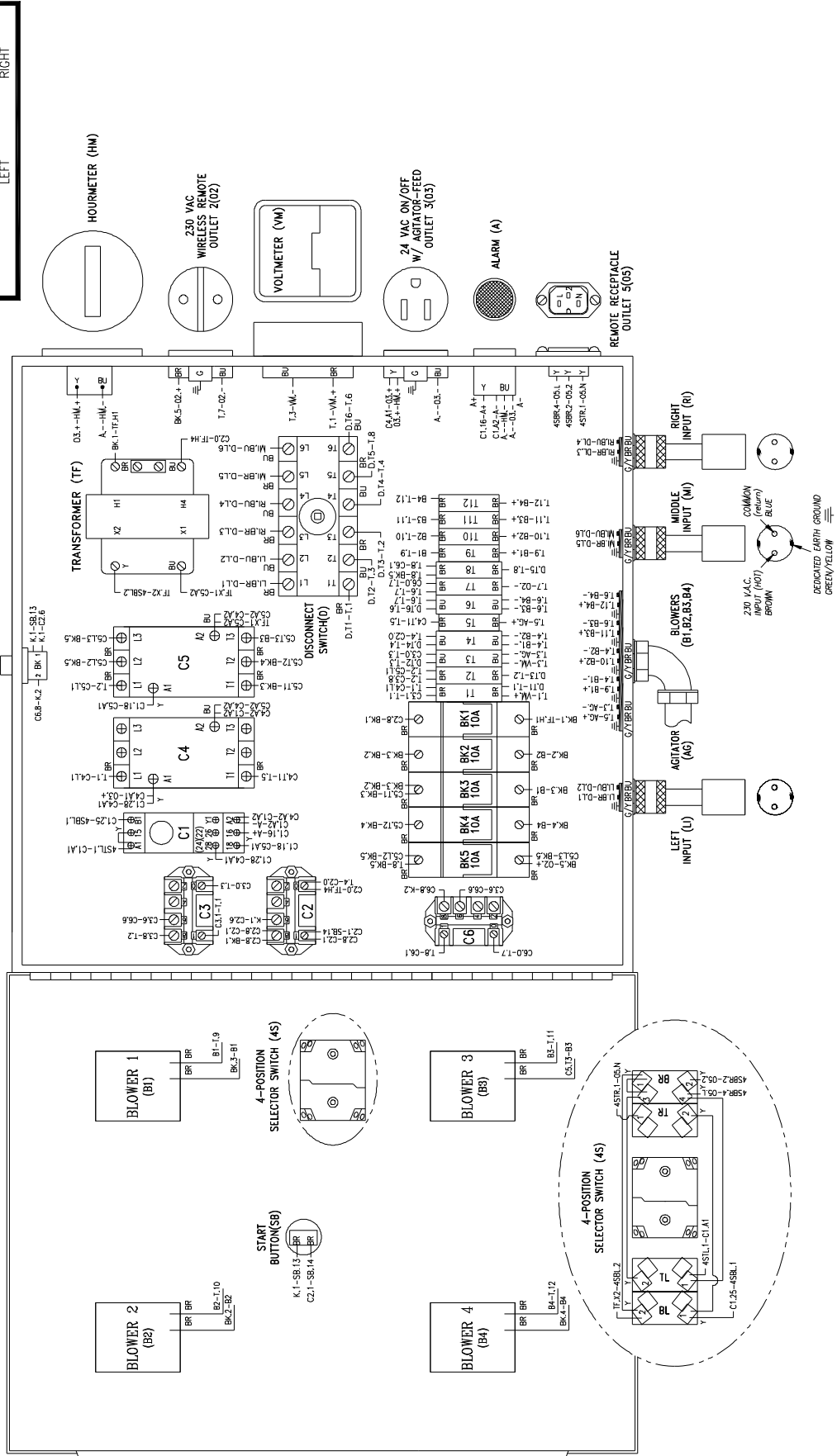

(Illustration X)

LADDER DIAGRAMS

**MODEL #1300/2300
2 BLOWER PANEL BOX
120 VOLT 60 HZ DOUBLE INPUT**

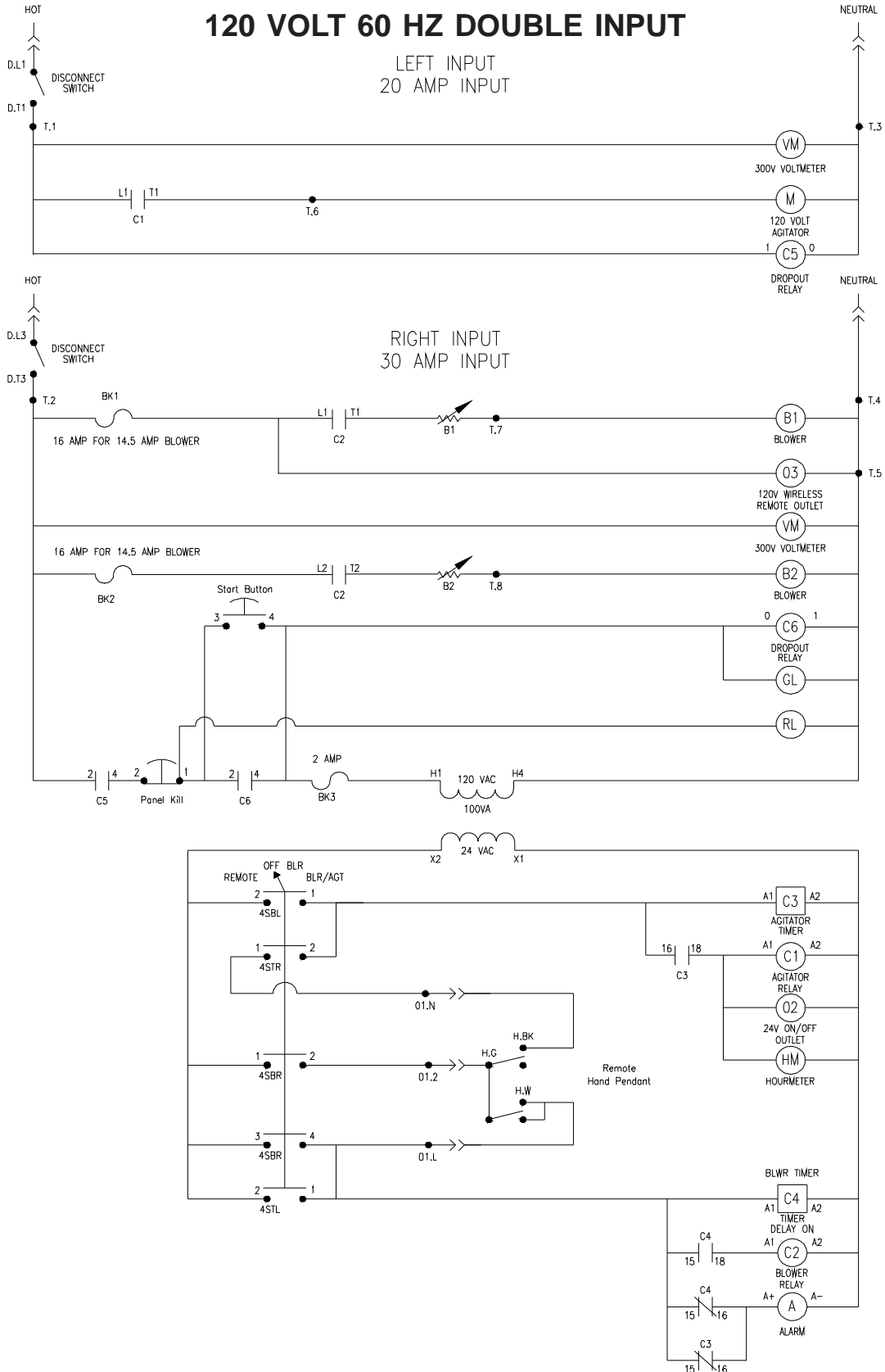

**MODEL #1300/2300
2 BLOWER PANEL BOX
240 VOLT 60 HZ
30 AMP SINGLE INPUT**

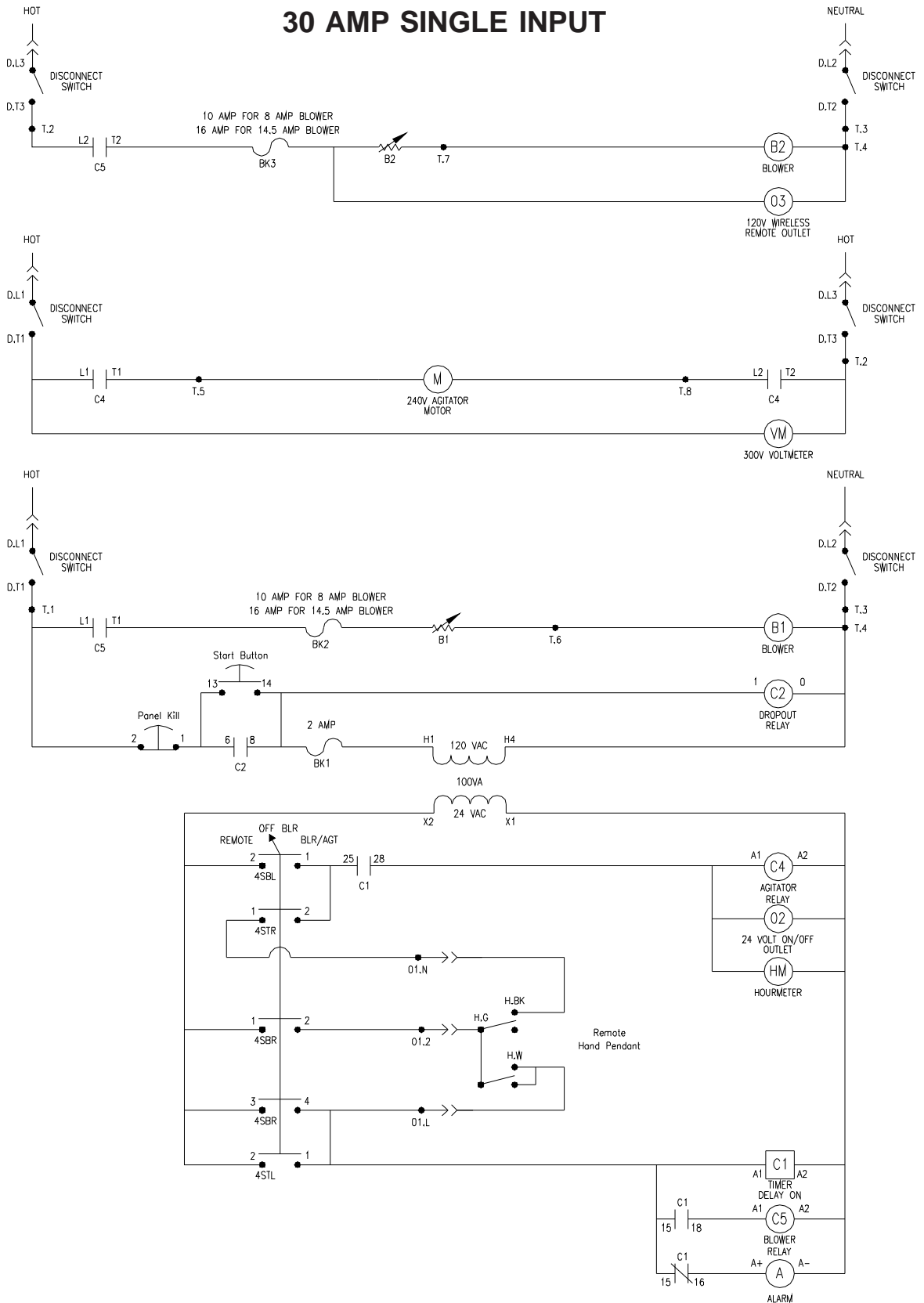

**MODEL #1300/2300
4 BLOWER PANEL BOX
240 VOLT 60 HZ
50 AMP SINGLE INPUT**

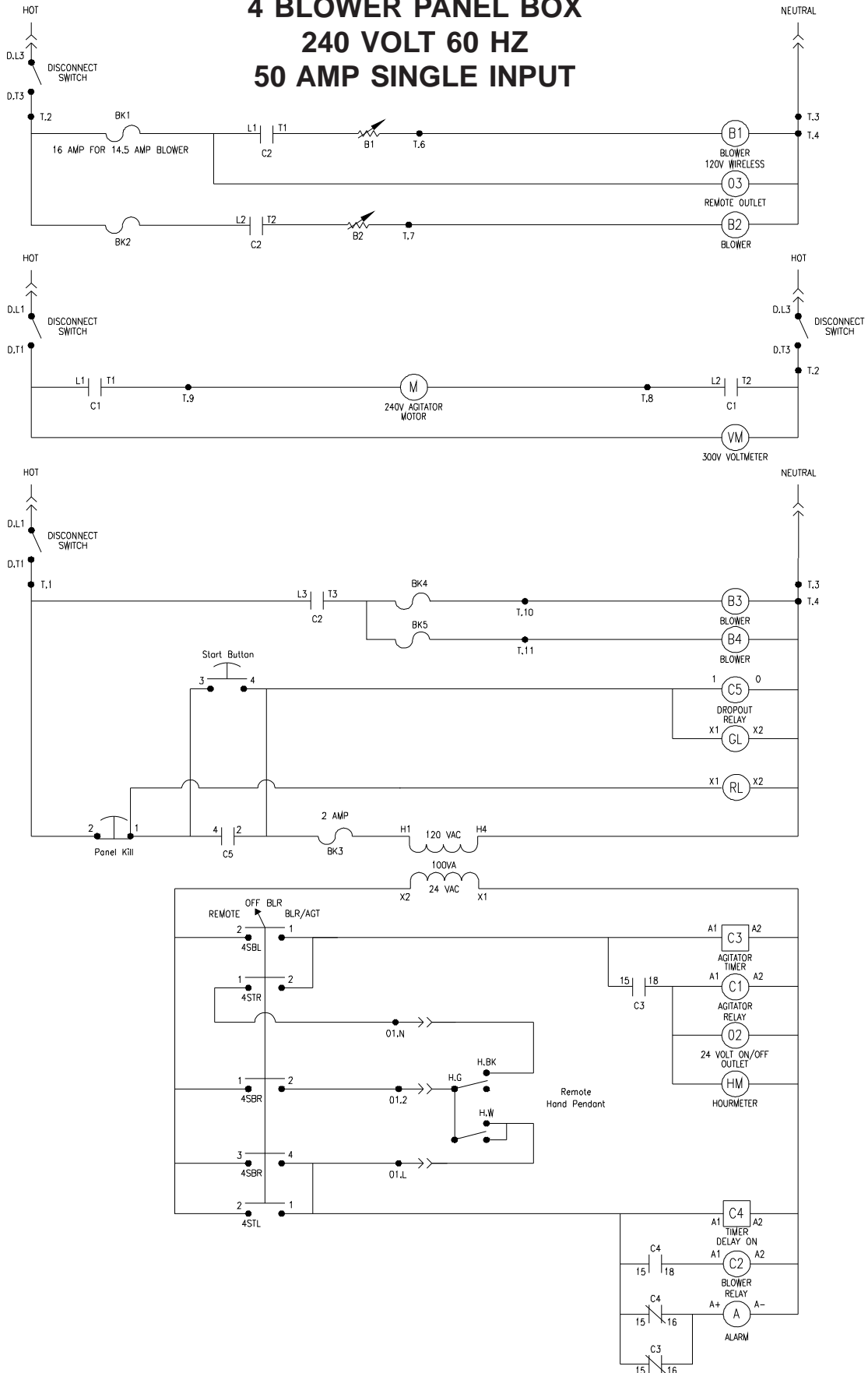

**MODEL #1300/2300
2 BLOWER PANEL BOX
230 VOLT 50 HZ
15 AMP DOUBLE INPUT**

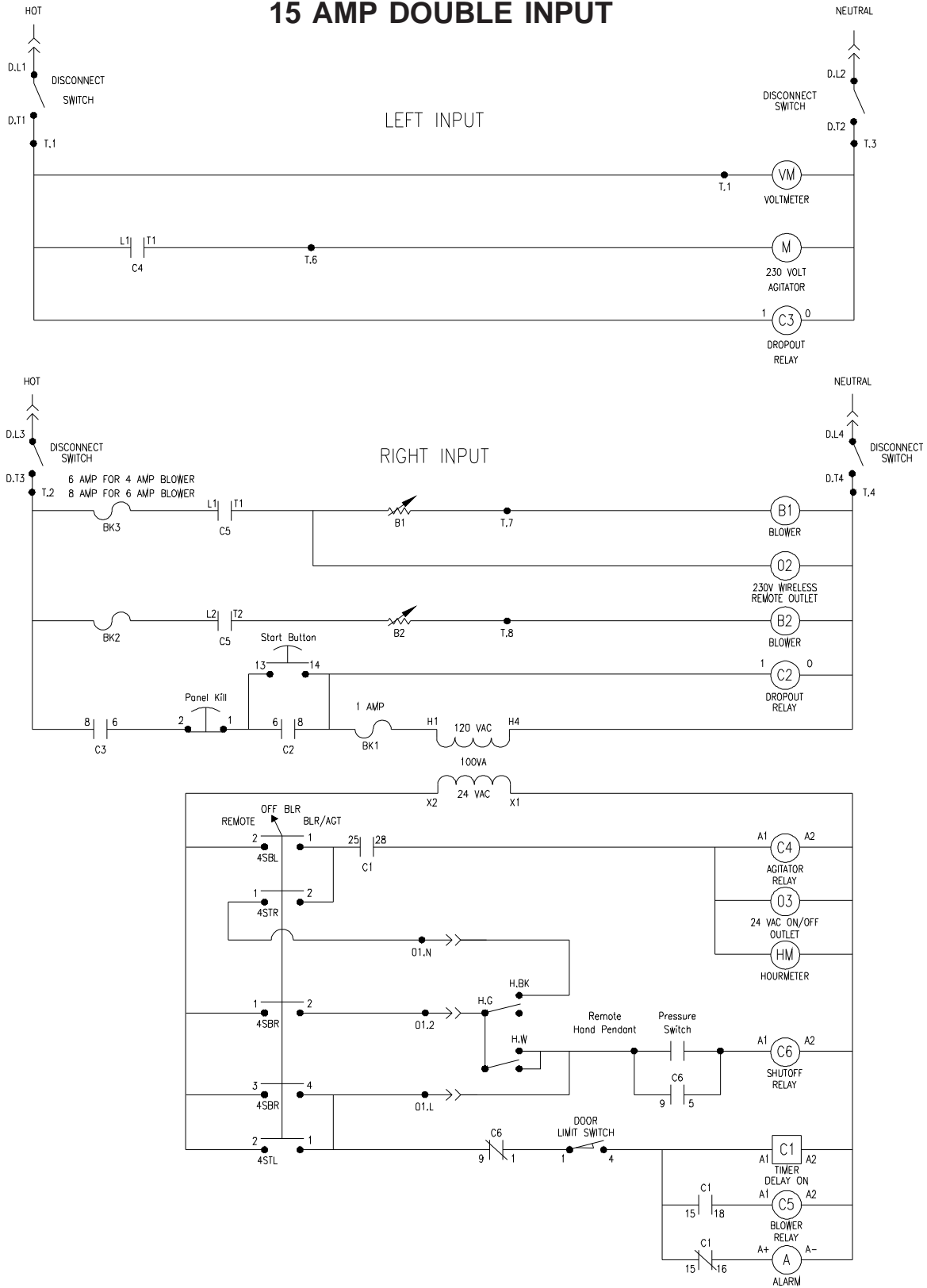

MODEL #1300/2300
4 BLOWER PANEL BOX
230 VOLT 50 HZ
15 AMP TRIPLE INPUT
 RIGHT INPUT

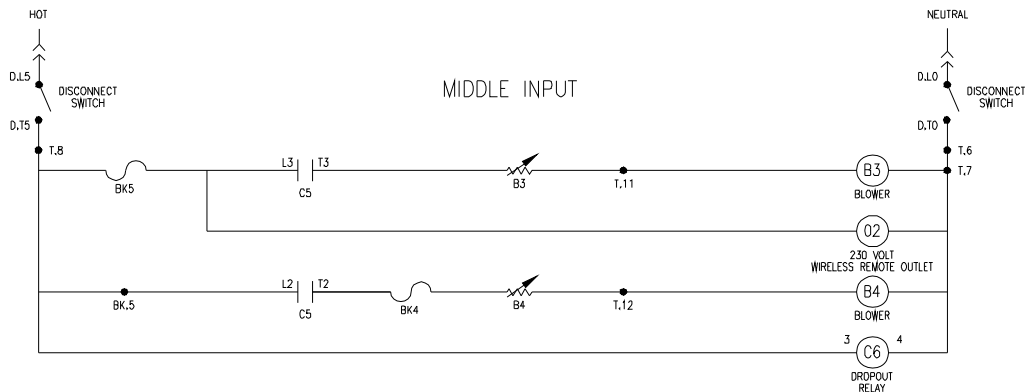
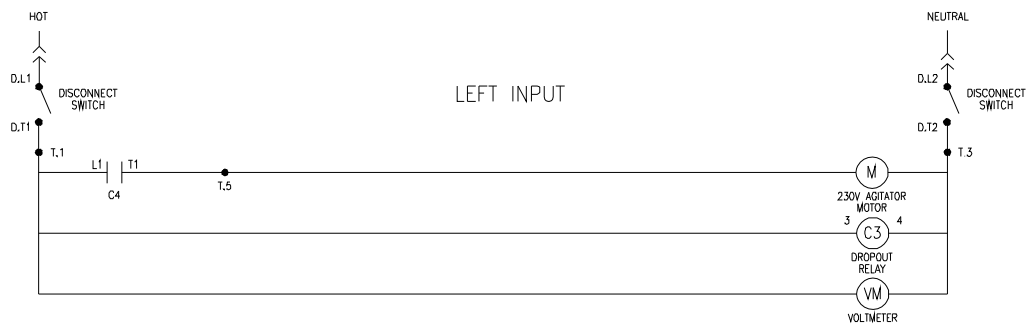
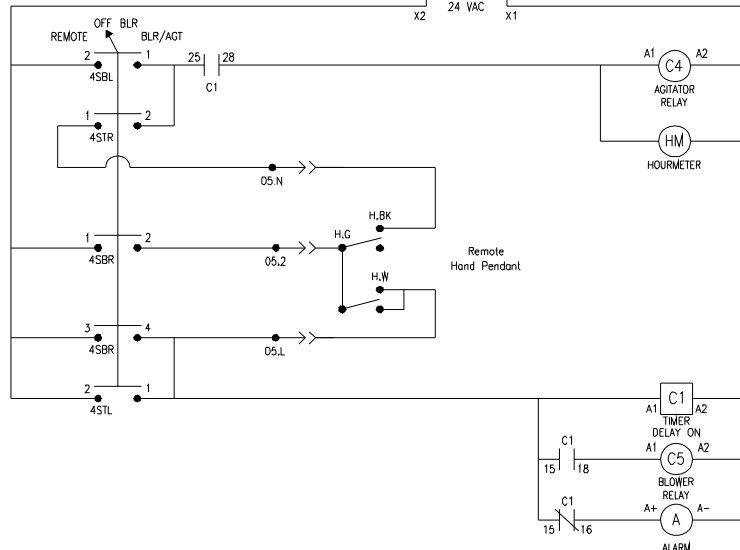
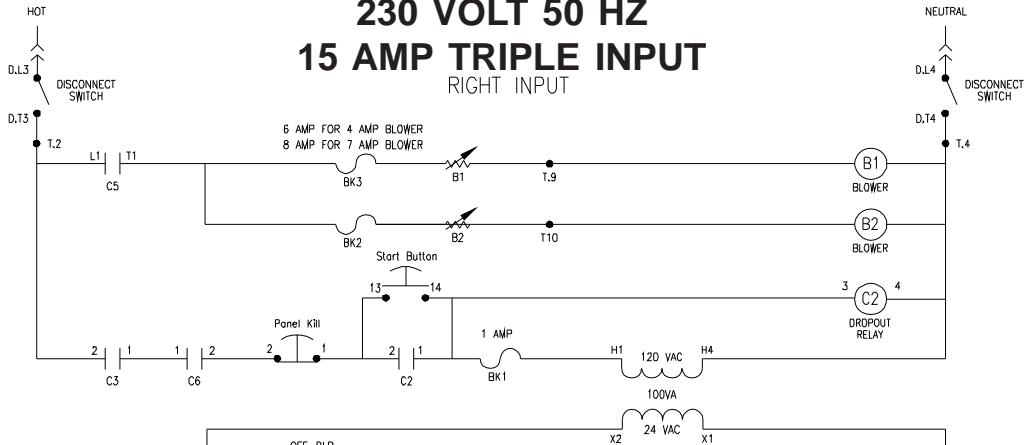

TROUBLESHOOTING**WARRANTY**

This unit is backed by a warranty for manufacturer's defects. If machine needs service during that time, call your supplier immediately. **Do not** attempt to service, as this voids warranty.

IMPORTANT

At any signs of trouble with your machine, stop immediately, disconnect power and call your supplier. Refer to *General Maintenance* section of this manual for further details. Always disconnect electrical power before making inspection or repairs.

Mechanical Troubleshooting

Problem	Corrective Action
1) Loud knocking sound.	<p>A. Disconnect power from unit. Check machine agitators or airlock for foreign objects and remove. Refer to <i>General Maintenance</i> for access to airlock.</p> <p>B. Disconnect power from unit. Check and retension chains.</p>
2) Poor output or uneven flow through the hose.	<p>A. Gradually increase blower control setting and/or close slidegate until condition improves.</p> <p>B. Check hose. Remove hose from airlock outlet and check for blocked material. Clean out by shaking hose. Connect hose to airlock, turn blowers on high (no agitator/feed) for a few moments and try to free blockage.</p> <p>C. Check insulation hose and blower hoses on machine for damage. Check connections. Tighten hose clamps to eliminate air leakage.</p> <p>D. Check for misaligned agitator tines.</p> <p>E. Disconnect power from unit. Inspect airlock seals and plates for damage or wear. Refer to page 16 and 17 of <i>General Maintenance</i> and follow instructions for replacing seals.</p> <p>F. Check for proper shredder direction. (See page 15 of <i>Mechanical Settings</i>.)</p>
3) Too much dust on open blow.	<p>A. Reduce air into system by decreasing blower control setting and opening slidegate.</p> <p>B. Use internal wetting system.</p>

Electrical Troubleshooting

IMPORTANT



Whenever power is interrupted to unit (i.e., unplugged, main disconnect switch off, kill switch depressed), power must be restored by correcting power interruption condition and pressing *green* start button.

Problem	Corrective Action
1) Voltmeter showing no voltage or low voltage.	A. Turn Main Disconnect Switch to ON position. B. Check input cord(s) for proper connection to power source. C. Check power source for proper voltage. D. Open Main Control Panel door and check voltage with multimeter at voltmeter terminals. Replace defective voltmeter. E. On single input, 240volt/60hz. units, check for proper wiring of four prong plug and connector body.
2) Dropout relay does not engage.	A. Check voltmeter. If no voltage, refer to #1 above. B. Check power on both input cords. (double input machines) C. Check indicator tab on the top of the dropout relay. If tab is out, relay is not engaged. If tab is in, relay is engaged. On double input machines, check the dropout relay on the top (C3). (If tab is "in", refer to #3.)
3) Dropout relay is engaged (tab is "in"), but machine will not run.	A. Check transformer breaker (BK1) with continuity tester. B. Check secondary output of transformer (24volt). Replace if necessary
4) Machine does not function with hand pendant while 4-Position Selector Switch is in REMOTE mode.	A. Check for proper start-up conditions as mentioned at beginning of this section. (See #2) B. Be sure remote control cord is properly plugged into Main Control panel. C. Check remote control cord and hand pendant switch for damage or loose connections. D. If neither Remote mode or Manual mode will function, check transformer breaker (BK1) with continuity tester.
5) Blower motor does not run, but agitator motor does run.	A. Check operation in remote mode and manual mode with 4-Position Selector Switch and remote hand pendant. B. Check blower control for ON position. C. Check for broken or loose wiring connections in Main Control Panel. D. Check blower motor. Disconnect power supply and visually inspect system for defective, broken or loose wiring connections inside blower box or blower unit. E. Check blower breaker(s) in Main Control Panel with a continuity tester. F. Check Blower Controls. Disconnect Blower Control wires on Main Control Panel door and reconnect the two power leads bypassing the Blower Control. (Blower will run full speed only.) G. Visually inspect and/or replace blower relay (C5) inside Main Control Panel.

Electrical Troubleshooting (cont.)

- 6) Blower motor does not run in manual mode. (4-Position Selector Switch.)
- A. Check wiring connections on Selector Switch contacts. (Located on back of Main Control Panel door.)
- 7) Blower motor running hot.
- A. Clean or replace Filter. Check inside Blower Box (for debris/insulation. Blow out blower motor and surrounding area with compressed air.
- B. Check material hose for blockage. A restriction in the material output hose will cause the blowers to run hotter than normal.
- C. Check blower motor for proper operation. (i.e. bearings, armature, or worn brushes.)
- 8) Excessive arcing of brushes on blower motor. (Model #1300/2300)
- A. Blow out brush assembly area with compressed air to remove accumulation of dirt and debris.
- B. Check blower motor for proper operation. (i.e. bearings, armature, etc.)
- C. Replace brush assembly. (See page 19 and 20 of *General Maintenance*.)
- 9) Agitator motor does not run, but blower motor does run.
- A. Manual Reset on agitator is tripped. Disconnect power supply to machine. Wait until agitator motor cools, (approximately 15 minutes), and press button on motor to reset.
- B. Check for broken or loose wiring connection in Main Control Panel.
- C. Check agitator motor. Disconnect power supply and visually inspect system for defective, broken, or loose wiring connections.
- D. Visually inspect and/or replace agitator relay (C4), inside Main Control Panel.
- 10) Agitator motor running improperly or hot.
- A. Disconnect power. Check agitators and airlock for debris.
- B. Low voltage. Try another electrical source. Use proper wire size for power input cords.
- C. Check bearings, sprocket and chain for binding, failure, or drive system misalignment.
- D. Remove vertical drive chain from airlock and upper agitators. Run motor/reducer and airlock assembly under power. Check amperage.
- E. Make sure the voltage, cycle (hertz), phase (1 or 3), and direction of rotation is correct.
- F. Replace agitator motor and/or speed reducer.
- 11) Agitator or airlock feeder not turning.
- A. Check sprockets for missing key. Replace with 1/4" key.
- B. Chain broken or off sprocket. Repair or replace.
- C. Check gearbox for sheared key between motor and reducer.
- 12) Pre-alarm sounds too long or continues without activating machine.
- A. Pre-alarm relay C1 (timer relay with knob adjustment), should be turned counterclockwise/left. This will reduce time duration of alarm.
- B. Replace relay module.

PARTS LIST

The manufacturer recommends that all repairs be made at its own factory service center. Machine repair done by the manufacturer is warranted for 90 days on repair parts and workmanship.

If you choose to have repairs made elsewhere, we offer replacement parts that have been carefully inspected to insure they meet the specifications of the original part. Any disassembly and reassembly of the unit to replace the defective part must be done with care to insure proper fit and alignment. No warranty consideration will be extended on parts that appear to be mishandled. All units should be run for a few minutes without material to insure proper alignment. All questions regarding replacement of parts should be directed back to the factory.

IMPORTANT: Certain information is needed concerning your specific machine when ordering replacement parts

- Machine Model number (i.e. Model #1300) • Serial Number
- Date Purchased
- Voltage of unit (main input): 120V, 240V or 230V (overseas) - single, double, or triple input
- Main input power - single phase (1Ø)
- Cycle: 50 or 60 hz. (U.S. and North American models are 60 hz.)
(**Most** overseas units are 50 hz. Check invoice for correct cycle.)
- Blowers: two or four

If this information is not known, contact supplier with serial number of machine. This information is needed on mechanical parts as well as electrical components. (Due to mechanical adjustments that compensate for electrical requirements, the above information is needed.)

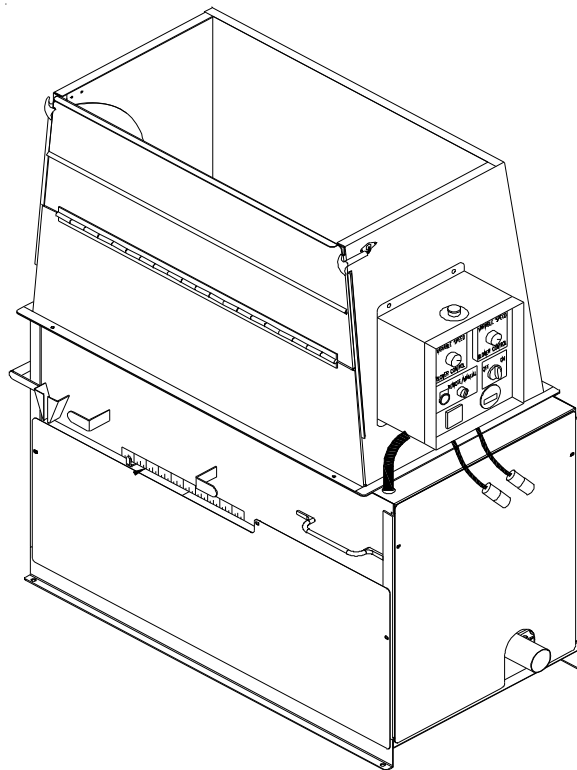

**MODEL #1300/2300
BASE UNIT and DRIVE ASSEMBLY**

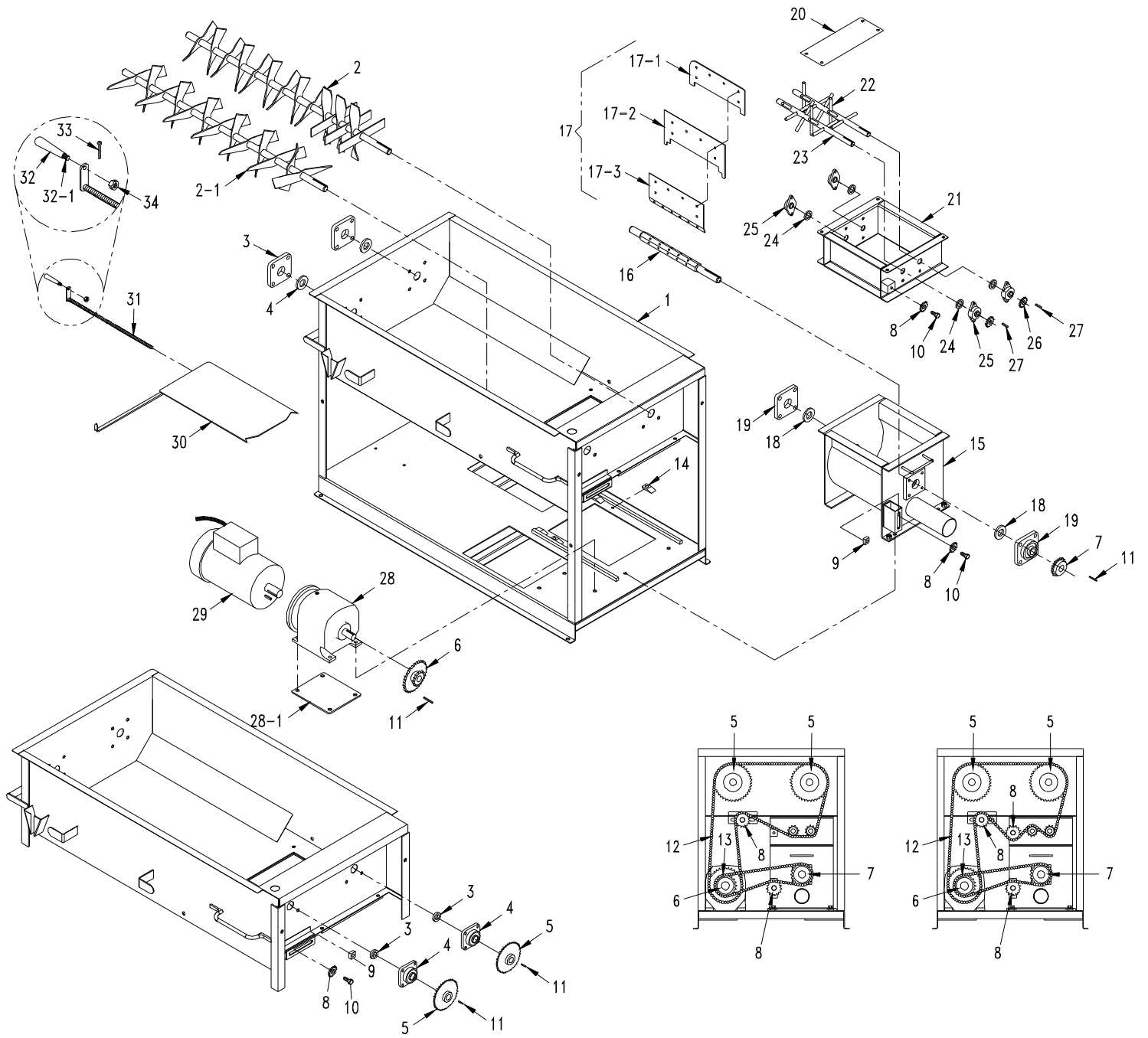

**MODEL #1300/2300
BASE UNIT and DRIVE ASSEMBLY**

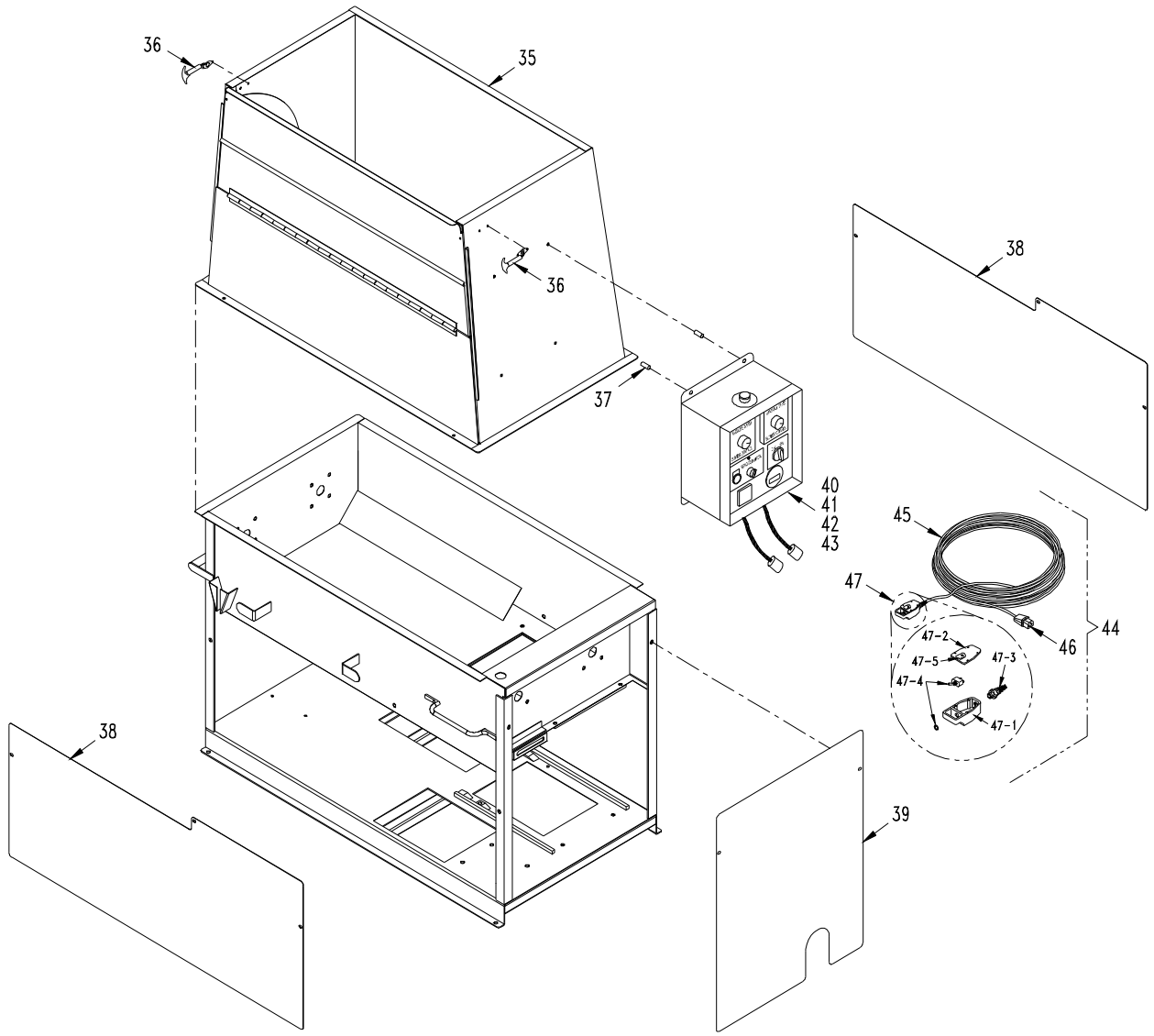

MODEL #1300/2300 BASE UNIT and DRIVE ASSEMBLY PARTS LIST

Item #	Part #	Description
1	23-3-R2-B	Base, Complete
2	13-9	Agitator, Shredder, 1 1/4"
2-1	13-8	Agitator, Hopper, 1 1/4"
3	250503-8	Bearing, 1 1/4", 4-Bolt Flange (4)
4	250503-7	Seal, Felt, 1 1/4" (4)
5	5200-42	#50 Sprocket, 40T x 1 1/4" Bore (2)
6	1300-6	#50 Sprocket, 35T x 15T x 1 1/4" Bore (U.S.)
6	2050-6	#50 Sprocket, 40T x 18T x 1 1/4" Bore (Overseas)
7	S-50BS15-A	#50 Sprocket, 15T x 1" Bore
8	150513	#50 Sprocket, Idler, 15T x 5/8" (3)
9	40052	Nut, 1" x 1 "x 1/2", Plated (2)
10	FSB120	Shoulder Bolt, 5/8" x 3/4" (3)
11	562	Key, 1/4" x 1/4" x 1 1/4" (4)
12	50NP-101	Chain, #50 x 101" (Uni-directional) (U.S. & Overseas)
12-1	50NP-2	Chain, #50 x 2" (Uni-directional to Center-Down) (U.S.) (Not Shown)
12-2	50NP-5	Chain, #50 x 5" (Uni-directional to Center-Down) (Overseas) (Not Shown)
13	109811	Chain, #50 x 37 1/2" (Airlock) (U.S.)
13	109801	Chain, #50 x 38 1/2" (Airlock) (Overseas)
14	23-3-1-3	Airlock Ramp, Model 1300
15	13-5-R2	Airlock, 3" in, 3" out, Model 1300
15	23-1-R1	Airlock, 3" in, 3" out, Model 2300
16	13-6	Shaft, Airlock, Model 1300
16	23-2	Shaft, Airlock, Model 2300
17	109031-8-ASSY	Seal Assembly, (2 PLY/FAB) 12", Model 1300
17	209031-8-ASSY	Seal Assembly, (2 PLY/FAB) 16", Model 2300
17-1	109031-9	Top Plate, 12", Model 1300
17-1	209031-9	Top Plate, 16", Model 2300
17-2	109031-8M-2PLYF	Seal, Airlock (2PLY/FAB) 12", Model 1300
17-2	209031-8M-2PLYF	Seal, Airlock (2 PLY/FAB) 16", Model 2300
17-3	109031-7	Base Plate, 12", Model 1300
17-3	209031-7	Base Plate, 16", Model 2300
18	517-7	Seal, Felt 1" Airlock (2)
19	517-6	Bearing, 1", 4-Bolt Flange (2)
20	13-7	Conversion Plate, Model 1300
21	13-4	Shredder box, Model 1300
21	23-4	Shredder box, Model 2300
22	13-2	Shredder Agitator, 7 Tine, Short, Model 1300
22	23-6	Shredder Agitator, 10 Tine, Short, Model 2300
23	13-3	Shredder Agitator, 6 Tine, Long, Model 1300
23	23-5	Shredder Agitator, 9 Tine, Long, Model 2300
24	426-7	Felt Seal, 3/4", Shredder Box (4)
25	426-6	Bearing, 3/4", 2-Bolt Flange (4)
26	S-50BS10	#50 Sprocket, 10T x 3/4" Bore (2)
27	448-1	Key, 3/16" x 3/16" x 1" (2)

**MODEL #1300/2300
BASE UNIT and DRIVE ASSEMBLY
PARTS LIST**

Item #	Part #	Description
28	250529	Reducer, 28:1 (U.S.)
28	1300-10	Reducer, 26.74:1 (Overseas)
28-1	13-14	Spacer, Reducer (Overseas)
29	23-12	Motor Assembly, 2 HP 120v/60hz
29	25-13	Motor Assembly, 2 HP 240v/60hz
29	13-11	Motor Assembly, 2 HP 230v/50hz
30	23-7	Slidegate
31	23-8	Slidegate Crankrod
32	1300-9	Handle
32-1	1300-9-1	Mounting Rod, Slidegate Handle
33	FSB078	Cotter Pin, 1/8" x 1"
34	FN015	3/8-16 Lock Nut, Crimped
35	1300-1-R2	Hopper Extension
36	23-99	Latch, Pull (2)
37	13-10	Spacer, ELU Box, 1 3/8" Long (2)
38	23-10-R2	Side Gaurd (2)
39	7-13C	Front Gaurd
40	ELU15-109068	ELU (120V, 60 Hz.) (double input 20 A & 30 A, double 14.5 A) Model #1300/2300
41	ELU12-109070	ELU (240V, 60 Hz.) (single input, double 14.5 A blowers) Model #1300/2300
41-1	ELU13-109071	ELU (240V, 60 Hz.) (single input 50 A (4) 14.5 A blowers) Model #1300/2300
42	ELU10-109072	ELU (230V, 50 Hz.) (double input, double 7 A blowers) Model #1300/2300
42-1	ELU11-109073	ELU (230V, 50 Hz.) (triple input, (4) 7 A blowers) Model #1300/2300
43	ELU11-109073-10	ELU (230V, 50 Hz.) (triple input, (4) 7 A blowers) Model #1300/2300
44	RC395-D	RC Cord Assembly, 150', ELU, Style D
45	18-3 SJ	Wire, #18-3 (SJ) x 150 feet
46	543-M-8	Plug, Style D (RC Cord)
47	RC395-DPDT	RC Service Kit (DPDT)
47-1	RC395-1	Switch Housing, Remote Control
47-2	RC395-2	Switch Back Plate, Remote Control
47-3	RC395-3	Strain Relief, Remote Control
47-4	109066-9	Switch, Toggle (DPDT)
47-5	1536-7	Belt Clip
47-6	KMC-087	Decal, Feed Blower (Not Shown)
47-7	RC395-4	8-16 Plastite Screw (4) (Not Shown)

**MODEL #1300/2300
BLOWER SYSTEM**

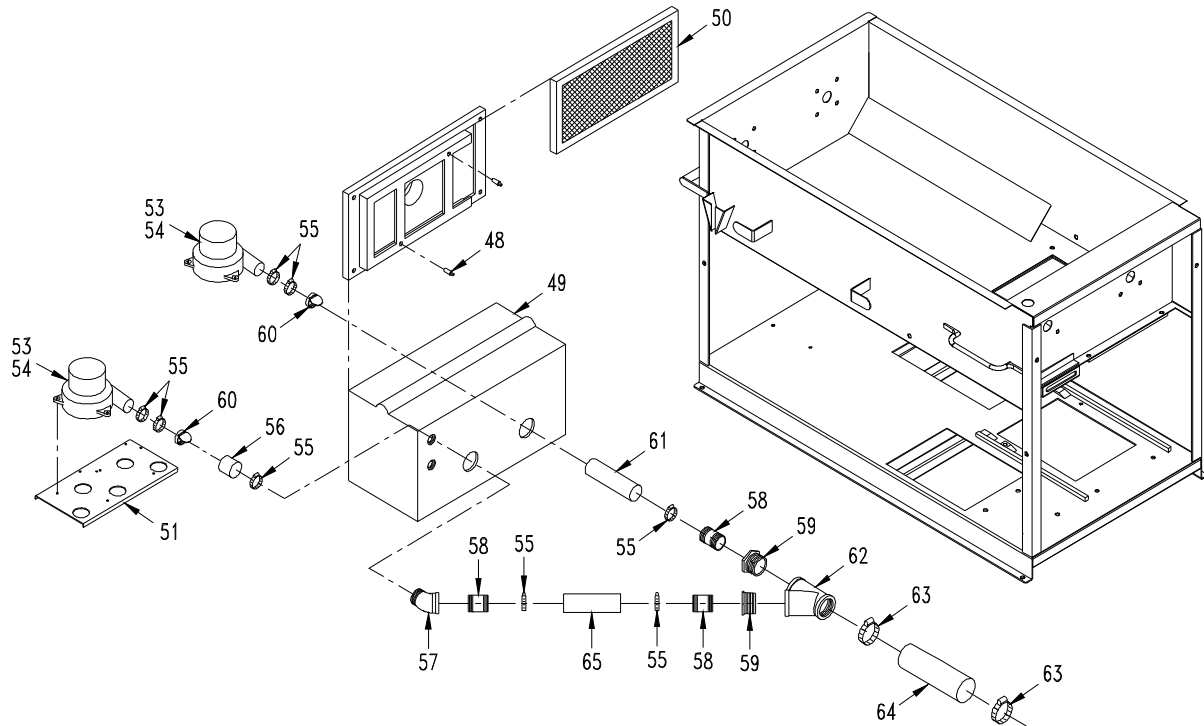

Item #	Part #	Description
48	P-1	Plug, Filter, Blower Box
49	7-4-P	Blower Box w/Door (Plastic)
50	411-A	Filter, 10" x 20" x 1"
51	109079	Blower Mount
53	408-E	Blower Motor, 12.5 amp, 3 Stage (2)
53	408-G	Blower Motor, 14.5 amp, 2 Stage (2)
54	408-F	Blower Motor, 6 amp, 3 Stage (2) (Overseas)
54	408-J	Blower Motor, 7 amp, 3 Stage (2) (Overseas)
55	337	Clamp, Hose 2" (8)
56	576	Hose, 2", 4" Long
57	7-16	Street Elbow, 1 1/2", 45 Degree
58	57801	Pipe Nipple, Close, 1 1/2" (3)
59	7-23	Bushing, 2" x 1 1/2" (2)
60	CV101	Check Valve, 2" (2)
61	23-31	2" Radiator Hose, 9" Long
62	7-17	2" Y Connector
63	339A	Hose Clamp, 3" (2)
64	1300-7	Hose, 3", 10 3/4" Long (Model #1300)
64	23-15	Hose, 3", 6 1/2" Long (Model #2300)
65	42516	2" Radiator Hose, 5 3/4" Long

**MODEL #1300/2300
OPTIONAL
4 BLOWER SYSTEM**

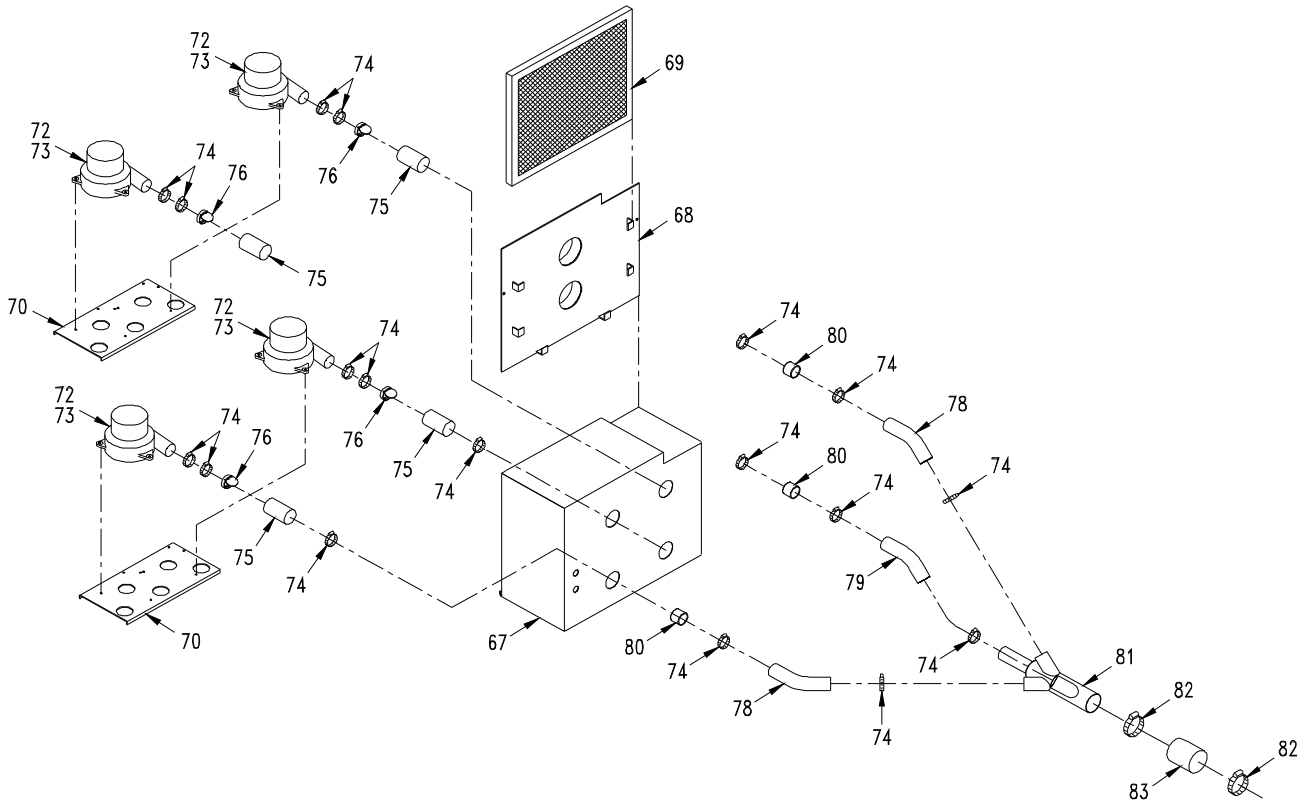

Item #	Part #	Description
67	23-13-R1	Blower Box, 4 Blower
68	23-14-R1	Blower Door, 4 Blower
69	13-12	Filter, 16" x 20" x 1"
70	109079	Blower Mount (2)
72	408-G	Blower Motor, 14.5 amp 2 Stage (4)
73	408-J	Blower Motor, 7 amp, 3 Stage (4) (Overseas)
74	337	Clamp, Hose 2" (18)
75	576	Hose, 2", 4" Long (4)
76	CV101	2" Check Valve (4)
78	52525	Hose, 2", 14" Long (2)
79	406	Hose, 2", 20" Long
80	50061	2" Input Tube (3)
81	23-18	Manifold, 4 Blower
82	339A	Hose Clamp, 3" (2)
83	1300-7	Hose, 3", 10 3/4" Long (Model #1300)
83	13-13	Hose, 3", 3" Long (Model #2300)

MODEL #1300/2300 120 V.A.C. 60 Hz. ELECTRICAL PARTS LIST (ELU15-109068)

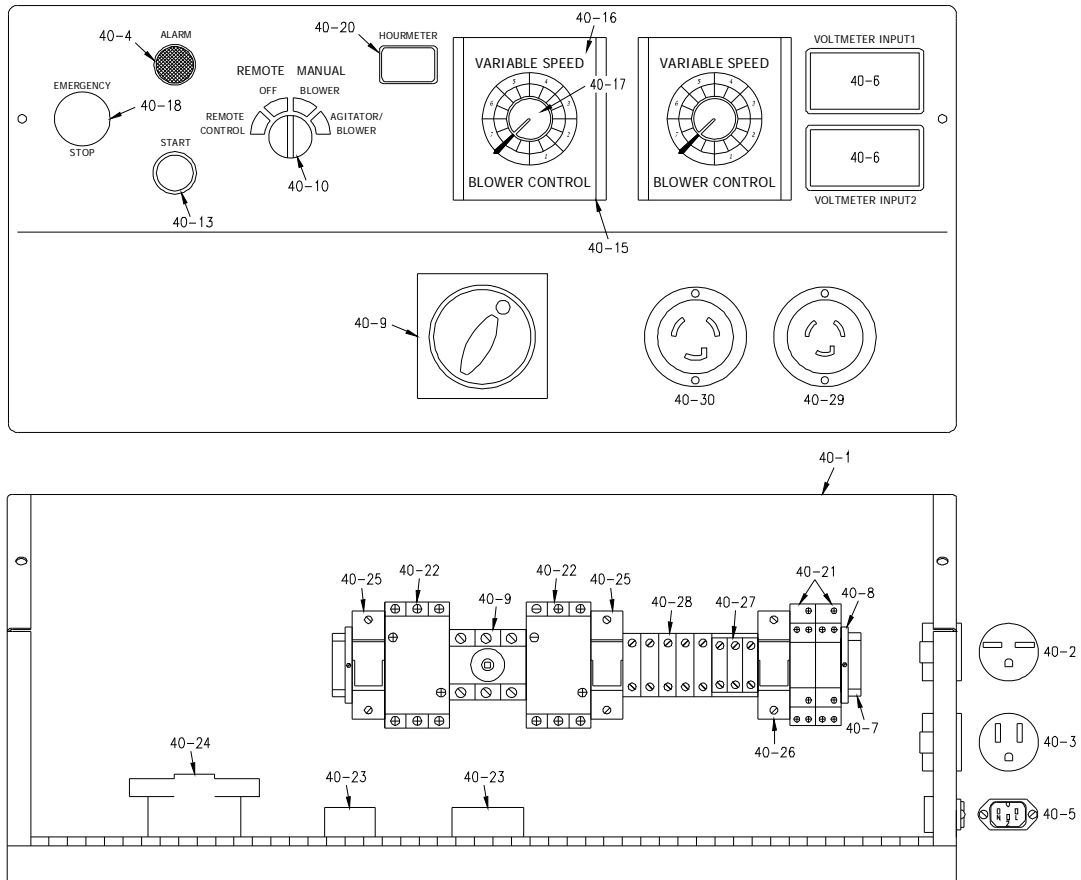

Electrical Exploded Parts List

Item#	Part#	Description	Item#	Part#	Description
40-1	543-M-102-R1	Box, Electrical	40-15	419-A	Blower Control (120V, 60Hz.) (2)
40-2	132-B	Receptacle, NEMA #6-15R	40-16	420-1	Cover, Blower Control (2)
40-3	1544	Receptacle, NEMA #5-15R	40-17	420-2	Knob, Blower Control (2)
40-4	543-M-38	Pre-Alarm System	40-18	543-M-46	Switch, Kill, Red
40-5	543-M-2	Receptacle, RC, Plug, #509-1050	40-19	8075-2	Contact Block 22mm Green (Kill Switch not shown)
40-6	543-M-83	Voltmeter, Digital 120V (2)	40-20	543-M-77	Hour Meter
40-7	ELU12-A	Dinrail, 1 3/8", 16"L	40-21	RELAY-10	Timer / Relay DPDT 12-240VAC 15A (2)
40-8	151080-49	Clamp, f/ 1 3/8" Din Rail (2)	40-22	ELU11-5	GE Contactor / Relay 25 Amp (2)
40-9	543-M-88	Switch, Disconnect Assy 3P	40-23	ELU10-10	Relay, Contactor/Relay, 120V Control (2)
40-10	543-M-22	Switch, 4-Position Selector	40-24	1530-D	Transformer, 4 Amp
40-11	543-M-15	Contact Block, Selector Switch (white) #KA-1 (not shown)	40-25	BRKR-16	Breaker, 16 Amp (2)
40-12	543-M-16	Contact Block, Selector Switch (red) #KA-3 (3) (not shown)	40-26	BRKR-2	Breaker, 2 Amp
40-13	543-M-14	Pushbutton On, Green	40-27	151080-61	Terminal Block, Small (3)
40-14	8075-2	Contact Block 22mm Green (2) (Pushbutton not shown)	40-28	151080-62	Terminal Block, Large (5)
			40-29	543-M-79	20 Amp Flange 120V TL
			40-30	543-M-67	30 Amp Flange 120V TL

MODEL #1300/2300 240 V.A.C. 60 Hz. ELECTRICAL PARTS LIST (ELU12-109070)

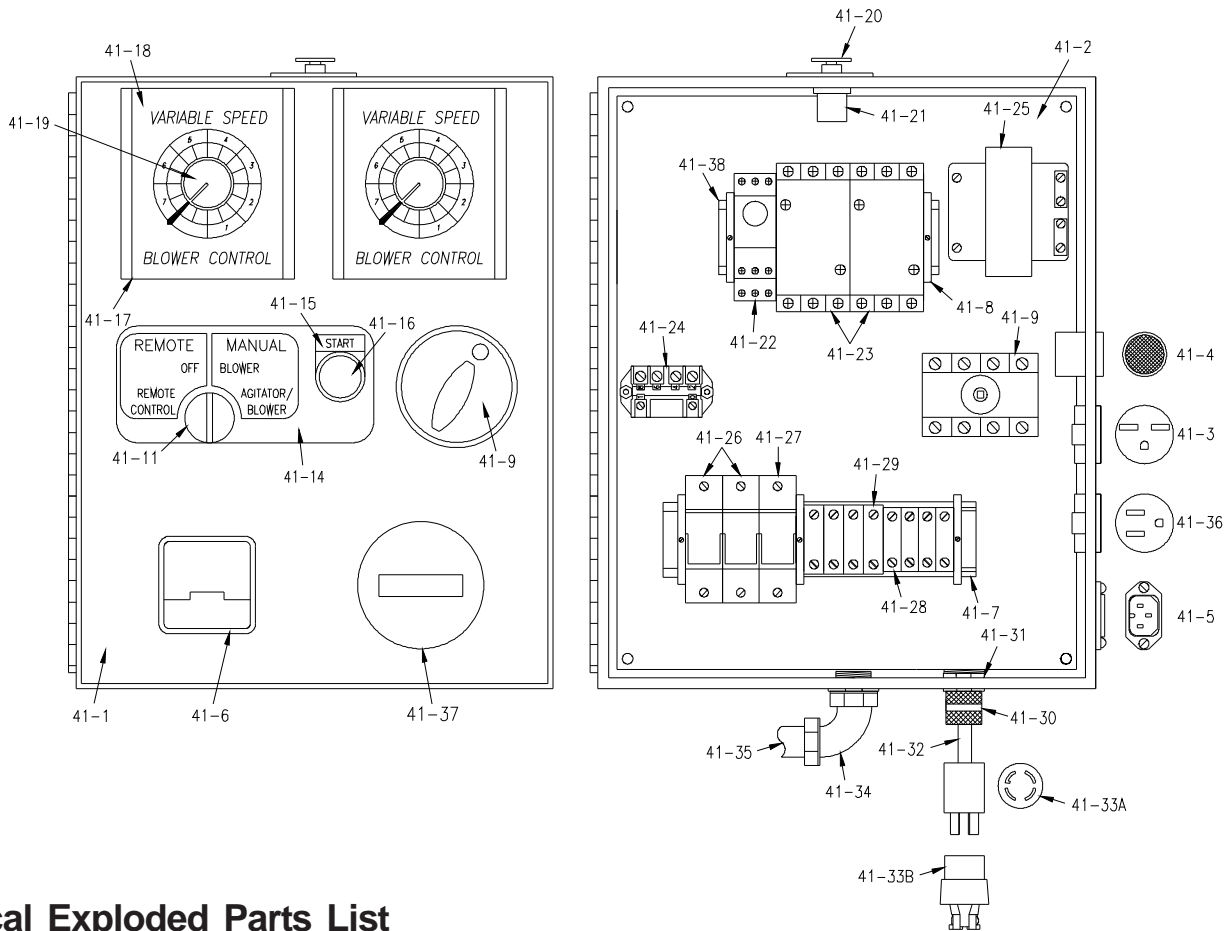

Electrical Exploded Parts List

Item#	Part#	Description	Item#	Part#	Description
41-1	543-M-31-R1	Box, Electrical 14" x 14" x 7"	41-21	8075-1	Contact, Kill Switch
41-2	543-M-31-4	Plate, Backing for Electric Box	41-22	ELU06-6	Timer, 24 VAC
41-3	132-B	Receptacle, NEMA #6-15R	41-23	ELU11-5	GE Contactor / Relay 25Amp (2)
41-4	543-M-38	Alarm for Pre-Alarm System, 24V	41-24	ELU10-10	Contact, Relay 120V Control
41-5	543-M-2	Receptacle, RC Plug #509-1050 (remote)	41-25	1530-D	Transformer, 4A
41-6	1531-B	Voltmeter, 0-300V	41-26	BRKR-16	Breaker, 16AMP (2)
41-7	ELU07-C	Dinrail, 1 3/8", 8 1/2" Long	41-27	BRKR-2	Breaker, 2AMP
41-8	151080-49	Clamp, f/ 1 3/8" Din Rail (4)	41-28	151080-61	Terminal Block, Small (4)
41-9	543-M-85	Disconnect Switch Assembly	41-29	151080-62	Terminal Block Large (4)
41-11	543-M-22	Switch, 4-position Selector	41-30	543-M-23	Connector, Cord, Liq. Tite, Straight
41-12	543-M-15	Contact Block, Selector Switch (white) #KA-1 (not shown)	41-31	391N-A-3	Locknut, Steel, Conduit, 1/2"
41-13	543-M-16	Contact Block, Selector Switch (red) #KA-3 (3) (not shown)	41-32	8-4 SJ	Cord, 8-4SJ
41-14	KMC-068	Decal, (Remote/Manual - 4-Position)	41-33A	109066-16	Plug, NEMA #L14-30P
41-15	543-M-60	Start Legend Plate	41-33B	109066-17	Connector, NEMA #L14-30C
41-16	543-M-59	Switch, Pushbutton On	41-34	543-M-25	Connector, Conduit, 1/2" 90 Degree
41-17	419-A	Blower Control (120V, 60Hz.) (2)	41-35	543-M-75	Conduit, 1/2" Flexible
41-18	420-1	Cover, Blower Control (2)	41-36	1544	Receptacle, NEMA# 5-15R
41-19	420-2	Knob, Blower Control (2)	41-37	7-21	Hourmeter, 50/60Hz 35 CPS
41-20	508-2	Switch, Kill	41-38	ELU10-A	Dinrail, 1 3/8", 5 1/2" Long
			41-39	543-M-31-2	Alarm Mount (not shown)
			41-40	ELU06-1	Cover, Transformer (not shown)

**MODEL #1300/2300 240 V.A.C. 60 Hz.
4 BLOWER ELECTRICAL PARTS LIST (ELU13-109071)**

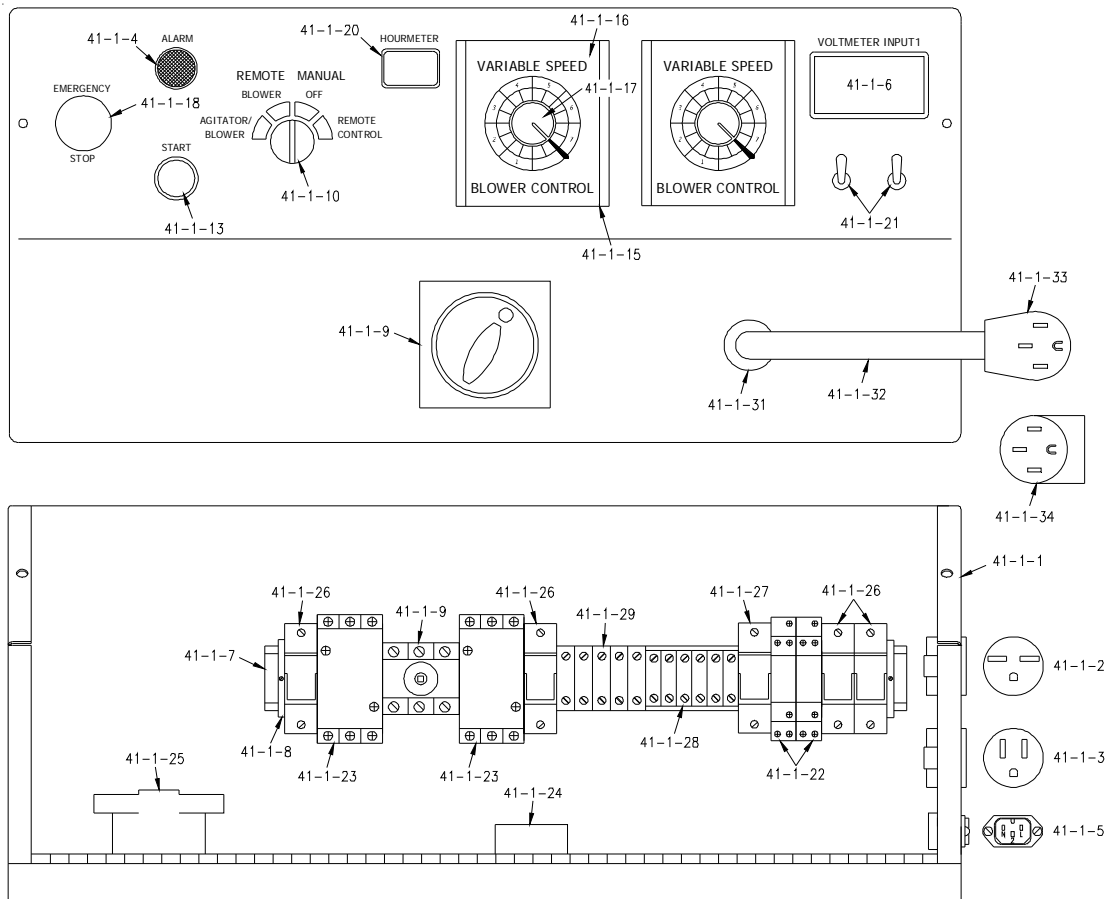

Electrical Exploded Parts List

Item#	Part#	Description	Item#	Part#	Description
41-1-1	543-M-103	Box, Electrical	41-1-18	543-M-46	Switch, Kill
41-1-2	132-B	Receptacle, NEMA #6-15R	41-1-19	8075-2	Contact Block 22mm Green (Contact Block Not Shown)
41-1-3	1544	Receptacle, NEMA #5-15R	41-1-20	543-M-77	Hour Meter
41-1-4	543-M-38	Alarm for Pre-Alarm System, 24V	41-1-21	1536-3	Switch, Toggle, SPST (2)
41-1-5	543-M-2	Receptacle, RC Plug #509-1050 (remote)	41-1-22	RELAY-10	Timer / Relay DPDT 12-240VAC 15A (2)
41-1-6	543-M-84	Voltmeter, 0-300V	41-1-23	ELU11-5	GE Contactor / Relay 25 Amp (2)
41-1-7	ELU12-A	Dinrail, 1 3/8", 16" Long	41-1-24	ELU10-10	Contactor / Relay 120V Control
41-1-8	151080-49	Clamp, f/ 1 3/8" Din Rail (2)	41-1-25	1530-D	Transformer, 4A
41-1-9	543-M-85	Disconnect Switch Assembly	41-1-26	BRKR-16	Breaker, 16 AMP (4)
41-1-10	543-M-22	Switch, 4-position Selector	41-1-27	BRKR-2	Breaker, 2AMP
41-1-11	543-M-15	Contact Block , Selector Switch (white) #KA-1 (not shown)	41-1-28	151080-61	Terminal Block, Small (6)
41-1-12	543-M-16	Contact Block , Selector Switch (red) #KA-3 (3) (not shown)	41-1-29	151080-62	Terminal Block Large (5)
41-1-13	543-M-14	Pushbutton On, Green	41-1-30	391N-A-3	Locknut, Steel, Conduit, 1/2"
41-1-14	8075-2	Contact Block 22mm Green (Contact Block Not Shown)	41-1-31	543-M-23	Connector, Cord, Liq. Tite, Straight
41-1-15	419-A	Blower Control (120V, 60Hz.) (2)	41-1-32	8-4 SJ	Cord, Input #8-4 (SJ)
41-1-16	420-1	Cover, Blower Control (2)	41-1-33	109610	Angle Plug, 6-50P
41-1-17	420-2	Knob, Blower Control (2)	41-1-34	109611	Connector, 6-50C
			41-1-35	ELU06-1	Cover, Transformer (Not Shown)

**MODEL #1300/2300 230 V.A.C. 50 Hz.
ELECTRICAL PARTS LIST (ELU10-109072)**

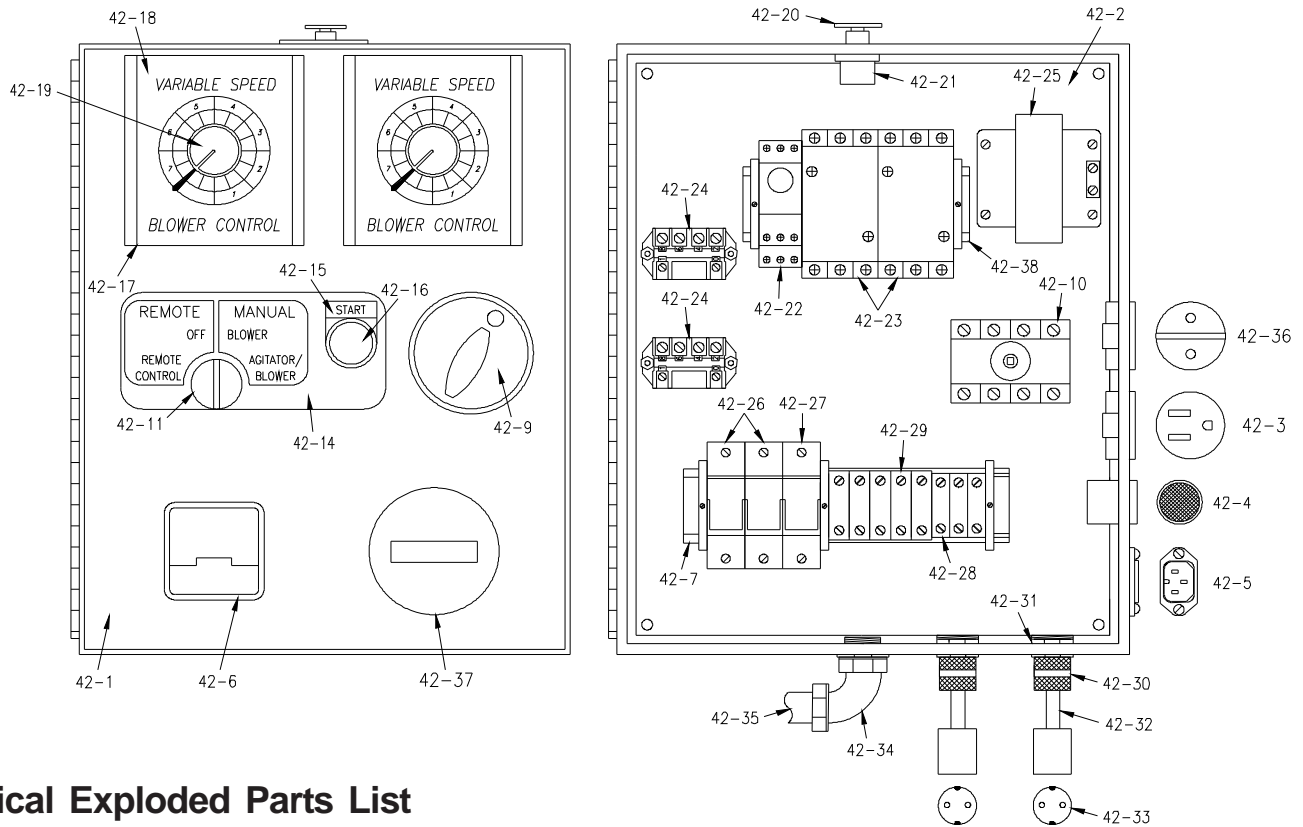

Electrical Exploded Parts List

Item#	Part#	Description	Item#	Part#	Description
42-1	543-M-31-R1	Box, Electrical 14" x 14" x 7"	42-21	8075-1	Contactors, Kill Switch
42-2	543-M-31-4	Plate, Backing for Electric Box	42-22	ELU06-6	Timer, 24 VAC
42-3	1544	Receptacle, NEMA# 5-15R	42-23	ELU11-5	GE Contactor / Relay 25 Amp (2)
42-4	543-M-38	Alarm for Pre-Alarm System, 24V	42-24	ELU10-12	Relay, E-Mech, CTRL-V230, DPDY-NO (2)
42-5	543-M-2	Receptacle, RC Plug #509-1050 (remote)	42-25	1530-D	Transformer, 4A
42-6	1531-B	Voltmeter, 0-300V	42-26	BRKR-8	Breaker, 8AMP (2)
42-7	ELU07-C	Dinrail, 1 3/8", 8 1/2" Long	42-27	BRKR-1	Breaker, 1AMP
42-8	151080-49	Clamp, f/ 1 3/8" Din Rail (4)	42-28	151080-61	Terminal Block, Small (3)
42-9	54-M-33-OS	Operator Handle Assembly (Overseas)	42-29	151080-62	Terminal Block Large (5)
42-10	543-M-33-D	Switch, Disconnect 40A #XA324BY	42-30	543-M-17	Connector, Cord, Liq. Tite, 1/2" Blue (2)
42-11	543-M-22	Switch, 4-position Selector	42-31	391N-A-3	Locknut, Steel, Conduit, 1/2" (2)
42-12	543-M-15	Contact Block, Selector Switch (white) #KA-1 (not shown)	42-32	12-3-SJ-M	12-3 SJ w/Brown/Blue/Green/Yellow
42-13	543-M-16	Contact Block, Selector Switch (red) #KA-3 (3) (not shown)	42-33	ELU06-9	Plug, European (2)
42-14	KMC-068	Decal, (Remote/Manual - 4-Position)	42-34	543-M-25	Connector, Conduit, 1/2" 90 Degree
42-15	543-M-60	Start Legend Plate	42-35	543-M-75	Conduit, 1/2" Flexible
42-16	543-M-59	Switch, Pushbutton On	42-36	543-M-78	Socket, Schuko, 16A Cover Panel
42-17	419-B	Blower Control (230V, 50Hz.) (2)	42-37	7-21	Hourmeter, 50/60Hz CPS35
42-18	420-1	Cover, Blower Control (2)	42-38	ELU10-A	Dinrail, 1 3/8", 5 1/2" Long
42-19	420-2	Knob, Blower Control (2)	42-39	ELU10-13	Cover, E-MECH Relay (2) (not shown)
42-20	508-2	Switch, Kill	42-40	ELU06-1	Cover, Transformer (not shown)

MODEL #1300/2300 230 V.A.C. 50 Hz. 4 BLOWER ELECTRICAL PARTS LIST (ELU11-109073)

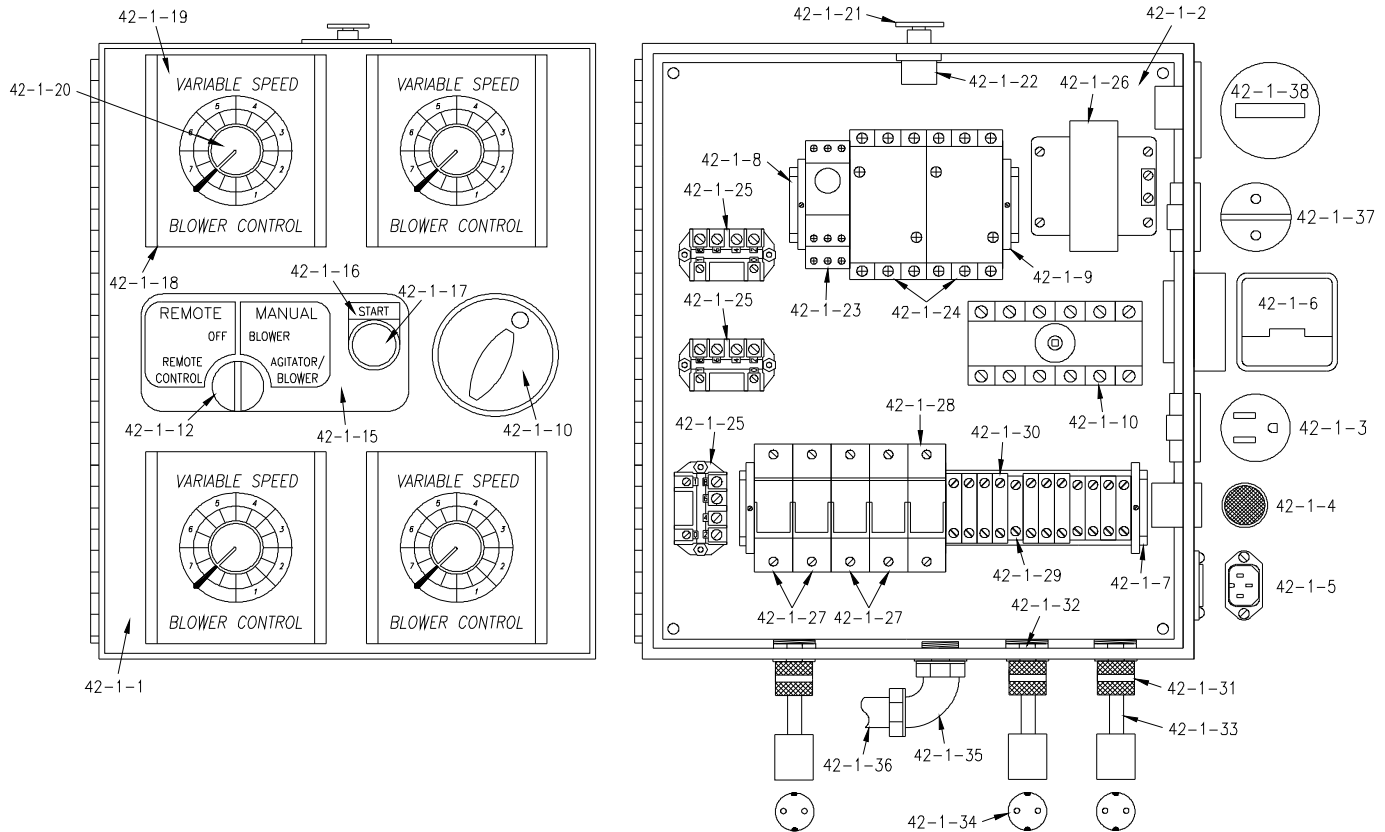

Electrical Exploded Parts List

Item#	Part#	Description	Item#	Part#	Description
42-1-1	543-M-40-R1	Box, Electrical 14" x 14" x 7"	42-1-21	508-2	Switch, Kill
42-1-2	543-M-31-4	Plate, Backing for Electric Box	42-1-22	8075-1	Contactora, Kill Switch
42-1-3	1544	Receptacle, NEMA# 5-15R	42-1-23	ELU06-6	Timer, 24 VAC
42-1-4	543-M-38	Alarm for Pre-Alarm System, 24V	42-1-24	ELU11-5	GE Contactor / Relay 25 Amp (2)
42-1-5	543-M-2	Receptacle, RC Plug #509-1050 (remote)	42-1-25	ELU10-12	Relay, E-Mech, CTRL-V230, DPDY-NO (3)
42-1-6	1531-B	Voltmeter, 0-300V	42-1-26	1530-D	Transformer, 4A
42-1-7	ELU07-C	Dinrail, 1 3/8", 8 1/2" Long	42-1-27	BRKR-8	Breaker, 8 Amp (4)
42-1-8	ELU10-A	Dinrail, 1 3/8", 5 1/2" Long	42-1-28	BRKR-1	Breaker, 1Amp
42-1-9	151080-49	Clamp, f/ 1 3/8" Din Rail (4)	42-1-29	151080-61	Terminal Block, Small (8)
42-1-10	543-M-82	Switch, Disconnect Grey/Black 6P	42-1-30	151080-62	Terminal Block Large (2)
42-1-12	543-M-22	Switch, 4-position Selector	42-1-31	543-M-17	Connector, Cord, Liq. Tite, 1/2" Blue (3)
42-1-13	543-M-15	Contact Block , Selector Switch (white) #KA-1 (not shown)	42-1-32	391N-A-3	Locknut, Steel, Conduit, 1/2" (3)
42-1-14	543-M-16	Contact Block , Selector Switch (red) #KA-3 (3) (not shown)	42-1-33	12-3-SJ-M	12-3 SJ w/Brown/Blue/Green/Yellow
42-1-15	KMC-068	Decal, (Remote/Manual - 4-Position)	42-1-34	ELU06-9	Plug, European (3)
42-1-16	543-M-60	Start Legend Plate	42-1-35	543-M-64	Connector, Conduit, 3/4" 90 Degree
42-1-17	543-M-59	Switch, Pushbutton On	42-1-36	543-M-68	Conduit, 3/4" Carflex
42-1-18	419-B	Blower Control (230V, 50Hz.) (4)	42-1-37	543-M-78	Socket, Schuko, 16A Cover Panel
42-1-19	420-1	Cover, Blower Control (4)	42-1-38	7-21	Hourmeter, 50/60Hz CPS35
42-1-20	420-2	Knob, Blower Control (4)	42-1-39	ELU10-13	Cover, E-MECH Relay (3) (not shown)
			42-1-40	ELU06-1	Cover, Transformer (not shown)
			42-1-41	550-3	Guard, Voltmeter (not shown)

**MODEL #1300/2300 230 V.A.C. 50 Hz.
4 BLOWER ELECTRICAL PARTS LIST (ELU11-109073-10)**

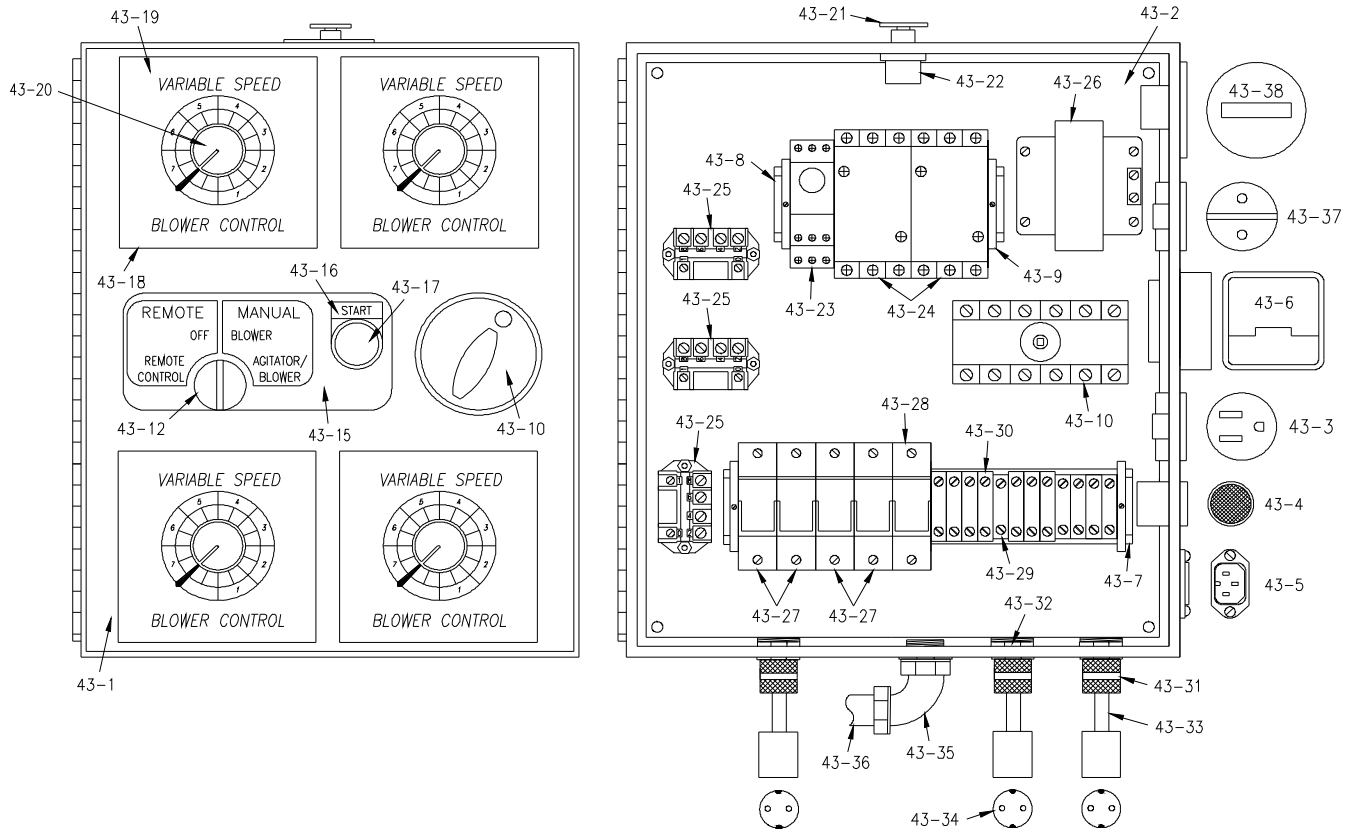

Electrical Exploded Parts List

Item#	Part#	Description	Item#	Part#	Description
43-1	543-M-40-R1	Box, Electrical 14" x 14" x 7"	43-21	508-2	Switch, Kill
43-2	543-M-31-4	Plate, Backing for Electric Box	43-22	8075-1	Contactora, Kill Switch
43-3	1544	Receptacle, NEMA# 5-15R	43-23	ELU06-6	Timer, 24 VAC
43-4	543-M-38	Alarm for Pre-Alarm System, 24V	43-24	ELU11-5	GE Contactora / Relay 25 Amp (2)
43-5	543-M-2	Receptacle, RC Plug #509-1050 (remote)	43-25	ELU10-12	Relay, E-Mech, CTRL-V230, DPDY-NO (3)
43-6	1531-B	Voltmeter, 0-300V	43-26	1530-D	Transformer, 4A
43-7	ELU07-C	Dinrail, 1 3/8", 8 1/2" Long	43-27	BRKR-10	Breaker, 10 Amp (4)
43-8	ELU10-A	Dinrail, 1 3/8", 5 1/2" Long	43-28	BRKR-1	Breaker, 1Amp
43-9	151080-49	Clamp, f/ 1 3/8" Din Rail (4)	43-29	151080-61	Terminal Block, Small (8)
43-10	543-M-82	Switch, Disconnect Grey/Black 6P	43-30	151080-62	Terminal Block Large (2)
43-12	543-M-22	Switch, 4-position Selector	43-31	543-M-17	Connector, Cord, Liq. Tite, 1/2" Blue (3)
43-13	543-M-15	Contact Block , Selector Switch (white) #KA-1 (not shown)	43-32	391N-A-3	Locknut, Steel, Conduit, 1/2" (3)
43-14	543-M-16	Contact Block , Selector Switch (red) #KA-3 (3) (not shown)	43-33	12-3-SJ-M	12-3 SJ w/Brown/Blue/Green/Yellow Plug, European (3)
43-15	KMC-068	Decal, (Remote/Manual - 4-Position)	43-34	ELU06-9	Plug, European (3)
43-16	543-M-60	Start Legend Plate	43-35	543-M-64	Connector, Conduit, 3/4" 90 Degree
43-17	543-M-59	Switch, Pushbutton On	43-36	543-M-68	Conduit, 3/4" Carflex
43-18	419-B	Blower Control (230V, 50Hz.) (4)	43-37	543-M-78	Socket, Schuko, 16A Cover Panel
43-19	420-1	Cover, Blower Control	43-38	7-21	Hourmeter, 50/60Hz CPS35
43-20	420-2	Knob, Blower Control	43-39	ELU10-13	Cover, E-MECH Relay (3) (not shown)
			43-40	ELU06-1	Cover, Transformer (not shown)
			43-41	550-3	Guard, Voltmeter (not shown)

GLOSSARY

BRIDGING	Tendency of insulation to cling in the hopper forming an air pocket above the airlock. This hinders the normal feeding process of the machine.
CFM	(Cubic feet per minute). A measurement of volume or quantity of air flowing at a certain rate, or air moving capability, of a blower. It is the volume of air moved per minute. Higher volume provides increased coverage and velocity of insulation as it leaves the hose.
CHECK VALVE	An apparatus that allows air to flow in one direction only. When mounted on the outlet of the blower, it protects the blower from insulation contamination through the air hose when using one blower. When the blower stops, the valve closes.
COMMERCIAL SPRAY ON	The application of insulation with adhesive to a surface which will remain exposed. The application must therefore be impacted in a smooth, uniform manner.
COVERAGE	Refers to the amount of insulation coverage, usually measured in square feet, according to the R-value desired. This information is given on the insulation package.
NEW CONSTRUCTION WALL CAVITY SPRAY	The spray application of insulation with water or adhesive into an exposed wall cavity to later be covered with drywall sheathing, etc.
PSI	(Pounds of pressure per square inch). The force exerted on a surface by air/liquid. High-pressure blowers push the insulation through the hose. Higher pressure provides less hose plugging and increased compaction in side wall.
PRODUCTION RATE	Pounds of insulation blown per hour.
RPM	(Revolutions per minute). Speed at which the shaft of a rotating device (i.e. blower fan, agitator) is moving.
R-VALUE	Resistance value. A precise measurement of the insulation's resistance to heat transfer. The higher the resistance value, the slower the heat will transfer through the insulating material.
RETRO-SIDEWALL	This refers to the installation of insulation into an unexposed wall cavity. Insulation is usually installed through holes drilled into the exterior siding.
SETTLED DENSITY	The point at which the insulation will not continue to settle further. Any insulation blown will have a certain amount of progressive settling that occurs after a period of time. Following the insulation manufacturers recommendations for bag rate coverage will provide useful information to accommodate for settling.
SETTLING	Compression or compaction of insulation fibers caused by the weight of the material, vibration of structure, temperature, and humidity cycles.

SERVICE RECORD

DATE	MAINTENANCE PERFORMED	COMPONENTS REQUIRED



55 YEARS OF AMERICAN INGENUITY

Made in the U.S.A.

**KRENDL MACHINE COMPANY • 1201 SPENCERVILLE AVE
DELPHOS, OHIO 45833 • TELEPHONE 419-692-3060 • FAX 419-695-9301
E - MAIL: krendl@krendlmachine.com • WEB SITE: www.krendlmachine.com**
