



The Innovator in Insulation Equipment



OWNERS MANUAL

GV230



60 YEARS OF AMERICAN INGENUITY

**KRENDL MACHINE COMPANY • 1201 SPENCERVILLE RD
DELPHOS, OHIO 45833 • TELEPHONE 800-459-2069 • FAX 419-695-9301
E - MAIL: krendl@krendlmachine.com • WEB SITE: www.krendlmachine.com**

CONGRATULATIONS ON YOUR PURCHASE OF KRENDL EQUIPMENT

**MODEL GV230
OWNER'S MANUAL**

FOR ASSURED SAFETY AND CONFIDENCE, PLEASE READ THIS MANUAL CAREFULLY BEFORE INSTALLING AND OPERATING YOUR MACHINE.

**E-MAIL ADDRESS IS: krendl@krendlmachine.com
WEB SITE IS: www.krendlmachine.com**

Table of Contents

Preface	1
General Safety Information	1
Decals	3
Returned Goods Procedure	4
Service	4
Warranty	5
Basic Components	6
Theory of Operation	6
Operating Instructions	7
Machine Hook-up	7
Machine Start-up	8
Machine Shutdown	8
Trouble Shooting	9
Maintenance	10
Fan Removal for Replacement	13
Fan Installation for Replacement	13
Belt Removal for Replacement	14
Belt Installation for Replacement	15
Exploded Parts List	16

Thank you for purchasing **KRENDL INSULATION MOVING EQUIPMENT**. With over sixty years experience in manufacturing insulation moving equipment, we have designed and built your equipment with the highest quality to provide years of reliable service.

This manual has been prepared to help you obtain the maximum efficiency and service from your Krendl equipment. The machine is designed to move insulation with the utmost in dependable performance. Our primary objective is to build equipment which will provide complete satisfaction.

Since Krendl Machine Company does not manufacture or sell insulation, our interest lies only in the proper performance of the equipment we manufacture. We make no recommendations or guarantees concerning various insulation.

CAUTION:



This manual contains important information regarding the **safe** assembly and operation of your machine. We urge you to read it carefully and follow the instructions provided. If your questions are not answered in this manual, please contact us. We want you to be able to operate this unit safely and confidently.

FILL IN AND RETAIN:

Krendl Machine Company
1201 Spencerville Rd
Delphos, Ohio 45833 U.S.A.

Telephone: 800-459-2069
Fax: 419-695-9301
E-mail: krendl@krendlmachine.com
Web Site: www.krendlmachine.com

For your protection in the event of theft or loss, please fill in the information requested for your own records. This information will be needed for warranty repairs. You may also want to attach a copy of your invoice.

Machine model number _____

Serial number _____

Date of purchase _____

Supplier / Distributor _____

General Safety Information



Important: Read **all** instructions **before** operating this equipment. This equipment can be potentially dangerous and must be used in strict accordance with instructions.



Disclaimer Notice: The manufacturer will not be legally responsible for any injury or damage resulting from the improper use of this equipment or the failure to follow instructions.



General Safety

- Read this manual carefully and become familiar with your equipment. Know its applications, limitations, and any operational hazards.
- This equipment was designed and manufactured for specific applications. Do not attempt to modify the unit or utilize it for any application in which it was not intended. If you have any questions about your intended use or the machines suitability, ask your supplier/distributor or consult the factory. Krendl Machine Company can not anticipate every circumstance that might involve a hazard. For that reason, warnings in the manual and warning tags and decals affixed to the unit, are **not** all-inclusive. Do not handle, operate, or service the unit by a procedure or method not specifically recommended by the manufacturer.



Electrical Safety

- The **National Electric Code** (NEC) in the United States and many international electrical codes require frame and external electrically conductive parts of this machine to be properly connected to an approved earth ground. Local electrical codes may also require proper grounding of machine. Consult with local electricians for grounding requirements in your area.
- Take care and follow these instructions when removing or installing the battery or electrical burn could occur. When removing battery, disconnect positive cable first followed by negative cable. When installing battery, connect negative cable first followed by positive cable.
- Reference NFPA 79, 70E, or OSHA safe work practices when performing energized work procedures.



Safety/Caution

- **Be Safe** - **ALWAYS** remove key from ignition and disconnect red positive battery cable before performing any maintenance or service to vacuum.
- **Be Safe** - Keep hands, loose clothing, jewelry and hair away from moving parts.
- **Be Safe** - Make sure all guards are in proper place **before** operating vacuum. Guards and safety devices/switches should not be removed, modified or by-passed.
- **Be Safe** - Do not remove safety pins located in output tube, as injury may result.
- **Be Safe** - Do not remove fan chamber cover when key is in the **on** position.
- **Be Safe** - Keep work area clear of debris. Do not use vacuum to move stones, nails, or any other foreign debris.
- **Be Safe** - Consult a qualified technician to answer questions **before** attempting to service unit, as injury may result.
- **Be Safe** - Wear proper safety equipment, including protective gear, such as respirators, eye and ear protection.
- **Be Safe** - Use proper and secure clamping method for all insulation hoses to prevent uncontrolled stream bursts around operator.
- **Be Safe** - Do not operate machine alone.
- **Be Safe** - Do not leave machine unattended and energized.
- **Be Safe** - Turn machine off and disconnect battery before clearing jam or attempting to remove any object in the fan chamber.
- **Be Safe** - Use proper lifting when moving insulation and loading machine.
- **Be Safe** - Violation of the Owner's Manual or safety precautions may void warranty.



Make Sure!

- Vacuum is sitting on level surface or engine failure may occur.
- Both inlet and outlet hoses are attached and pushed on all the way to actuate safety switches, then secured with hose clamps before operating.
- Fan chamber is empty of foreign debris **before** starting as this can bind and stall your machine or damage the fan.
- Fan chamber cover is in place and properly secured before turning vacuum on.
- Vacuum is turned off **immediately** if hose is plugged.
- Vacuum is turned off **immediately** if there is excessive vibration as the fan may be out of balance.
- Vacuum is placed in an open area so that it receives "fresh air" and allows hot air from the engine to exhaust.

Decals



Rotating fan can be dangerous! Clothes, hair, hands, etc. can get sucked into vacuum chamber. Properly attach hoses before operation. Failure to do this could cause serious injury or death.



Rotating parts can be dangerous! You can snag clothes, hair, hands, etc. This can cause serious injury or death.



During operation, this machine is loud. Wear hearing protection. Failure to do this could result in hearing loss.



Manufacturer information is provided here along with machine model, and serial number.



Indicates which employee inspected equipment and on what date.

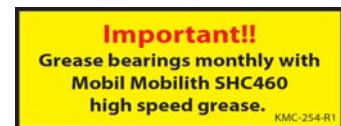

Indicates when to grease bearings on machine and with what type of grease.



Indicates location of the fuel shut-off valve.



Rotating parts will be moving in this direction.

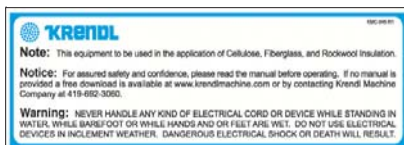

Identifies what type of insulation should be used with this machine and that the manual should be read before operating. Warns to be careful around electrical components! This can cause serious injury or death.



Indicates that the Krendl Machine Company is in compliance with EPA codes.



Part number for identification and tracking.



Be sure after using KEY is in the OFF position so as not to drain battery.



Do not smoke around machine. Machine contains a flammable liquid. Failure to do this could cause serious injury or death.



During operation, this area of machine is hot! Be careful not to touch. This can cause serious burns.



Indicates that the engine requires fresh air. Supplying the engine with fresh air will result in better performance and longer life.



During operation machine can eject flying debris. Wear appropriate safety equipment.



During operation machine must be on a level surface or engine failure may occur.



Hose must be on input and output tubes for safety switches to engage and machine run.

Returned Goods Procedure

IF MACHINE WAS NOT PURCHASED DIRECTLY FROM KRENDL MACHINE COMPANY, CONTACT YOUR SUPPLIER / DISTRIBUTOR.

When returning products to Krendl for repair, first obtain a return goods authorization, at which time you will be given shipping instructions. The product must be shipped **PREPAID**:

Krendl Machine Company
1201 Spencerville Rd
Delphos, Ohio 45833 U.S.A.

Telephone: 800-459-2069
Fax: 419-695-9301
E-mail: krendl@krendlmachine.com
Web Site: www.krendlmachine.com

Once the unit is received, it will be inspected. In-warranty units will be repaired and returned immediately. An estimate of repair charges will be provided for out-of-warranty units.

Service

See an Authorized Briggs & Stratton, Kohler or Honda Service Dealer. Each one carries a stock of Genuine Parts and is equipped with special service tools. Trained mechanics assure expert repair service on all these engines. Only dealers advertising as “Authorized” are required to meet these standards.

You may locate your nearest Authorized Service Dealer on the web at www.briggsandstratton.com, www.power.kohler.com, www.engines.honda.com or your local phone directory under “Engines, Gasoline” or “Gasoline Engines,” or “Lawn Mowers” or similar category.

WARRANTY

Krendl Machine Company (Company) warrants to each original purchaser (Buyer) of its machines that such products will be free of manufacturing defects for a period of 2 years from the date of shipment to the Buyer. (This does not include accessories, pumps, blowers, wall scrubbers, etc.)

No warranty is made with respect to:

1. Components or accessories manufactured and warranted by others. Warranties for purchased component parts as supplied from vendor such as engine, electric motor, blower, gearbox, transmission, etc., if furnished by the manufacturer of the component, are on file at the Company's main office and copies will be furnished at request of Buyer. Component(s), shipping costs prepaid, shall be sent to Company who in turn shall forward to vendor for evaluation and warranty determination.
2. Any defect caused by repair, alteration and/or adjustment performed by Buyer or customer/vendor of Buyer without the express written authorization of the Company.
3. The labor costs of replacing parts by parties other than the Company.
4. Any machine that has not been operated and / or maintained in accordance with normal industry practice and the written recommendations of the Company. (e.g. machine operated with an improperly sized, worn or damaged hose, improper or inattention to preventative maintenance, etc.)
5. The product has been subjected to misuse, negligence or accident or results of any application or use of the blowing equipment not in accordance with the Company recommendations.

This limited warranty does not cover the free replacement of component parts that become inoperative due to wear and usage and need to be replaced on a regular basis, including but not limited to: airlock seal(s), agitator(s), shredder(s), auger(s), fuse(s), switch(es), clutch(es), hose(s), shaft seal(s), chain(s), belt(s), sprocket(s), pulley(s), bearing(s), cable(s), battery(ies), filter(s), fan(s), etc.

The Company's obligation under this warranty is limited to repairing or replacing (at Company option) any part that is determined by the Company to be suffering from a manufacturing defect. The Company (at Company option) will provide any required parts and labor to the Buyer. If the equipment or parts must be returned to the Company for repair, all transportation costs shall be the Buyer's responsibility.

THIS LIMITED WARRANTY IS EXPRESSLY IN LIEU OF ANY OTHER GUARANTEES AND / OR WARRANTIES, ORAL OR WRITTEN, EXPRESSED OR IMPLIED, INCLUDING WITHOUT LIMITATION, THE IMPLIED WARRANTY OF MERCHANTABILITY. NO WARRANTY, EXPRESS OR IMPLIED, OTHER THAN THE AFORESAID WARRANTY IS MADE OR AUTHORIZED BY COMPANY. COMPANY SHALL NOT BE LIABLE FOR ANY DIRECT, INDIRECT, INCIDENTAL OR CONSEQUENTIAL DAMAGES TO PROPERTY OR INJURY TO ANY PERSON OR COSTS ASSOCIATED WITH LOSS OF PRODUCTION RESULTING IN LOSS OF REVENUE, PROFITS OR LOSS OF EQUIPMENT THROUGH THE USE OF THIS EQUIPMENT.

Note: Special job circumstances incurring costs for specialized repair and next day delivery of parts will not be reimbursed by the manufacturer unless authorized by factory.

Basic Components

This is a view of the basic components of your vacuum. It shows the location of each item and gives the function of each. Use this as a guide throughout the manual. (See Illust. A)

- A) **STAND** — Mobile frame unit that supports the motor, battery, and fan chamber.
- B) **ENGINE** — 23HP engine provides power to the fan.
- C) **FAN** — Unit that produces air current or vacuum.
- D) **FAN CHAMBER** — Protective housing that provides an enclosed air space for the fan to create a vacuum.
- E) **FAN CHAMBER COVER** — Provides access to the fan for general maintenance.
- F) **BATTERY** — Supplies power for the electric start on the engine.
- G) **HOURLY METER / TACHOMETER** — Monitors the use and speed of the engine. (**Note:** LUBE/CHG OIL will flash every 25 hours) (Not Shown)
- H) **FUEL TANK** — Provides the fuel necessary to run the machine.
- I) **LIMIT SWITCHES (2)** — Safety devices located on the input and output tubes to ensure hoses are attached properly. These switches must be engaged to allow engine to start.

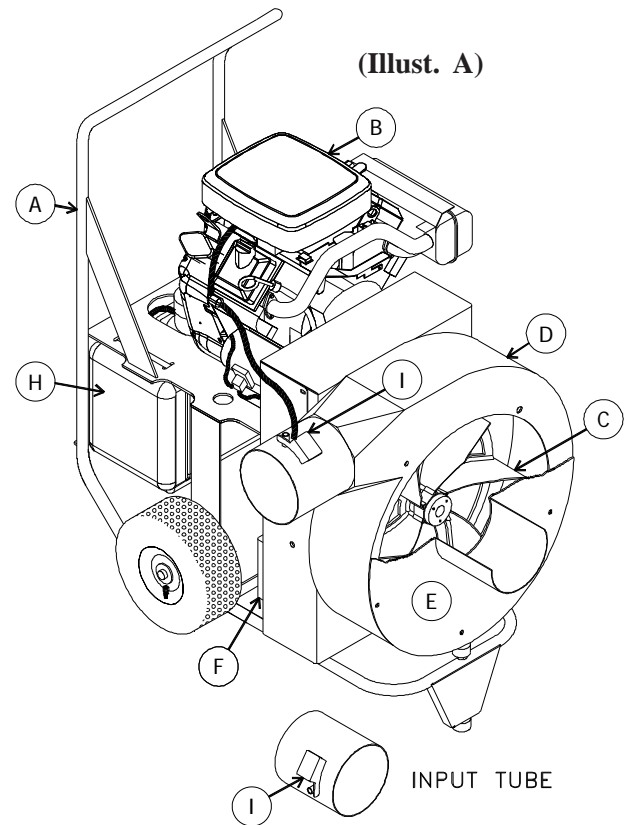

Theory of Operation

This unit is designed to move all recycled, existing attic loose fill insulation and new insulation materials from the job site and deliver them directly to a designated area such as a filter bag, dumpster, vacuum hopper, etc. (See Illust. B)

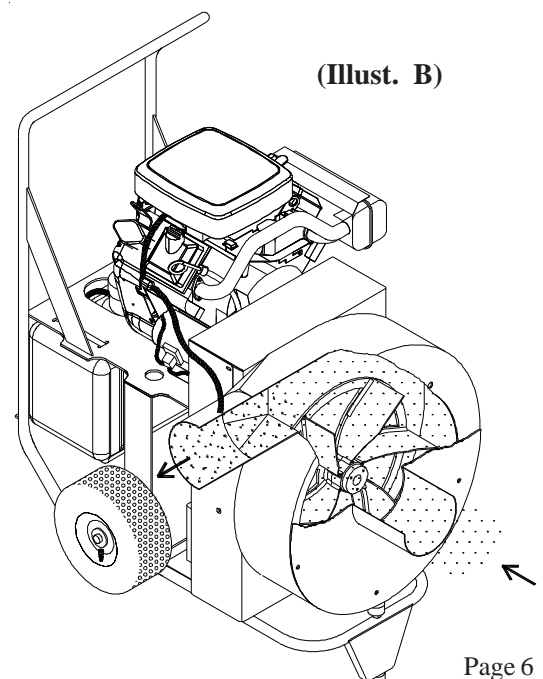

A common application for this unit is the vacuum hopper system. Once the insulation material has been deposited into the hopper, the air passes through the perforated mesh screen in the vacuum hopper, where it is filtered, and exhausted. (See Illust. C on page 7.)





Machine Hook-up

This unit comes ready for connection to the VH550 (vacuum hopper), VH550-B (vacuum hopper with bin level) and Vacuum Defender. **Note: A bin level indicator and blastgate are not used with the model VH550 (vacuum hopper).**

This unit provides a direct connection to 4" or 6" insulation hose depending on the use of a 6" to 4" reducer shown in (Illust. C & D). Slide hose on to the inlet and outlet of the gas vacuum and secure with hose clamps. **Note: Hose clamps are to be utilized with all hose connections to prevent air leakage and insure operator safety. Correct use of clamps also helps to prevent hose plugging.**

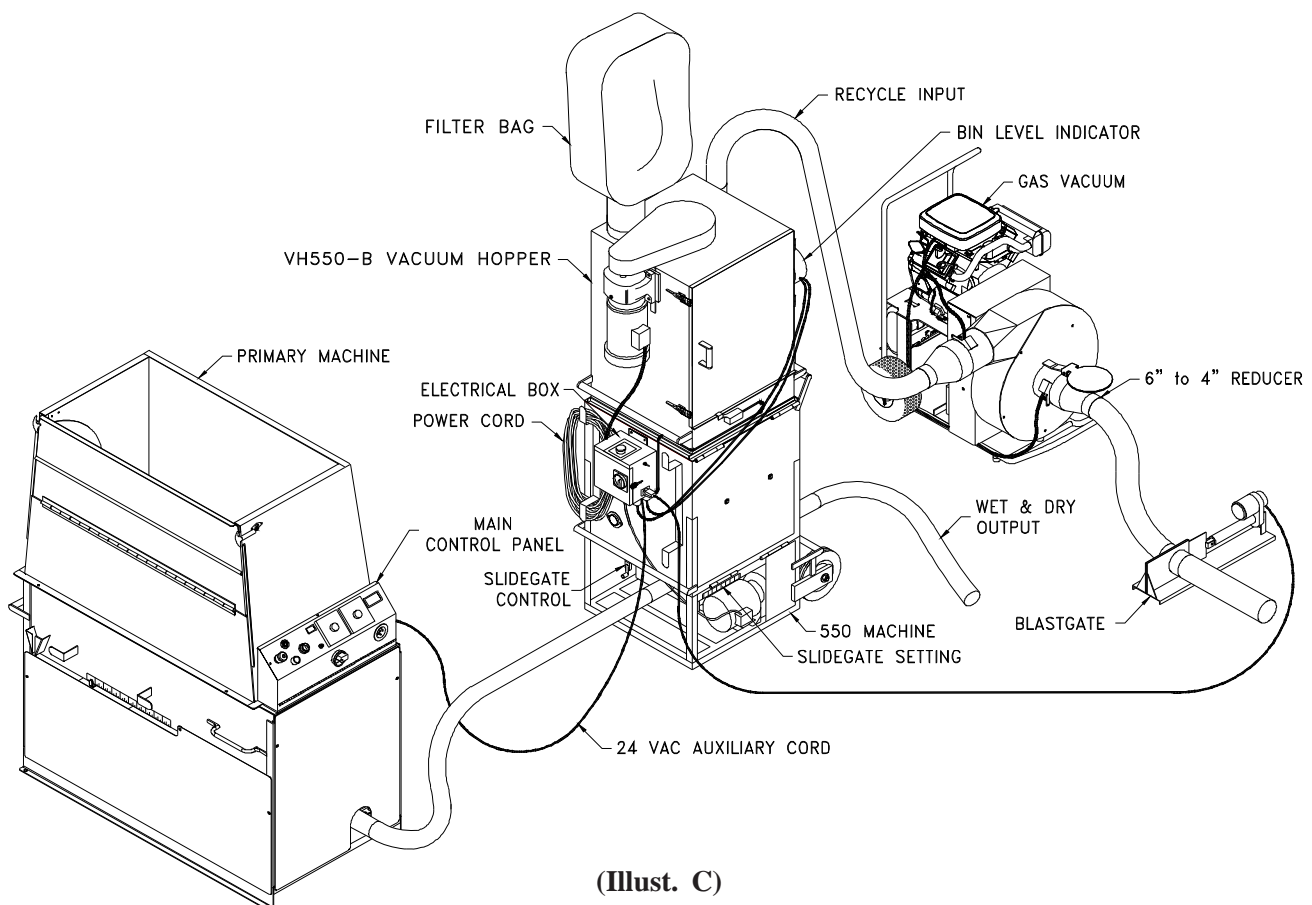
-  1.) **For hook-up to the VH550 (vacuum hopper) only.** Connect hose from gas vacuum outlet to vacuum hopper inlet. Slide hose on to the gas vacuum inlet. Secure all hose connections with hose clamps. (See Illust. C)
-  2.) **For hook-up to the VH550-B (vacuum hopper with bin level) only.** Connect hose from gas vacuum outlet to vacuum hopper inlet. Connect hose from gas vacuum inlet to blastgate outlet. Connect hose to the blastgate inlet. Secure all hose connections with hose clamps. (See Illust. C)



-  3.) **For hook-up to the Vacuum Defender and GV100 (bag removal).** Connect 5' to 10' of hose from gas vacuum outlet to reclaim bag inlet. Connect 10' to 15' of hose from gas vacuum inlet to vacuum defender outlet. Connect hose to the vacuum defender inlet. Secure all hose connections with hose clamps. (See Illust. D)

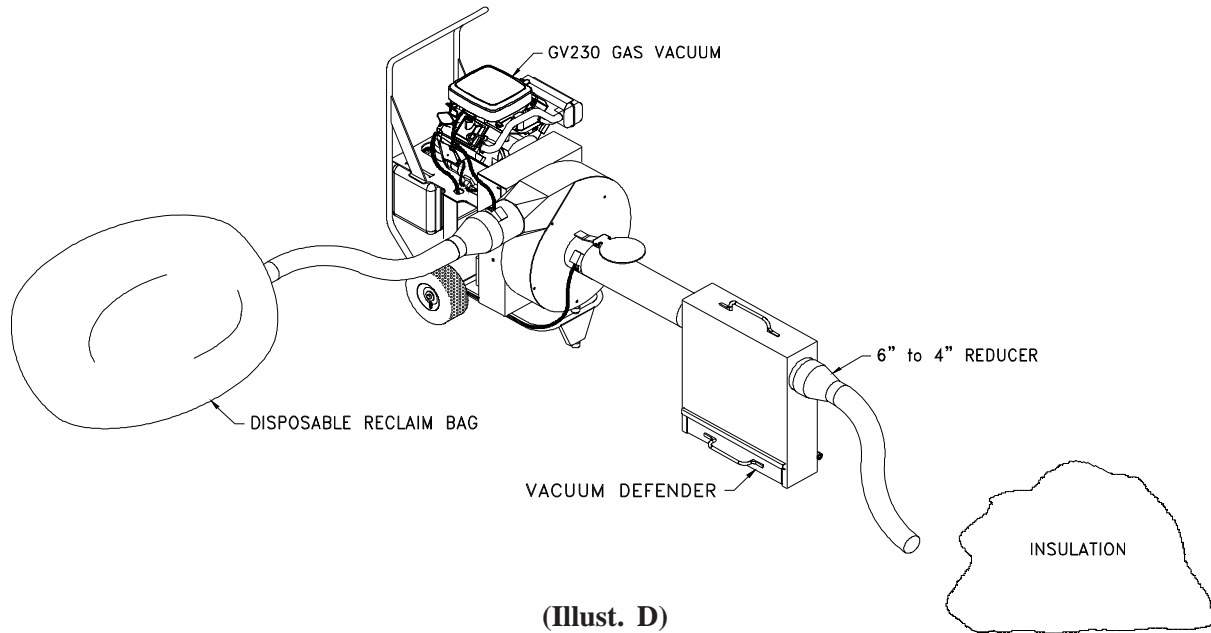

- ⚠ At all times keep your hands, clothing, foreign objects, etc. away from inlet and discharge of your gas vacuum.
- ⚠ Never operate vacuum without hoses attached.
- ⚠ **Note: The end user should perform a risk assessment when first using this equipment. The end user has knowledge of conditions the equipment is used in. Therefore, the end user can ensure that necessary control measures be implemented before equipment use. (Follow all local, state, federal, and/or DSEAR requirements.)**

Machine Start-up

- 1.) Place vacuum on level surface outside where the engine can receive fresh air and expel hot exhaust.
- 2.) Hook up hoses to the inlet and discharge, secure with clamps before operation.
- 3.) Move choke control to choke position.
- 4.) Move throttle control to fast position.
- 5.) Turn fuel shut-off valve on.
- 6.) Turn key to start position (repeat until engine starts).
- 7.) Move choke control to off position after start up.
- 8.) Move throttle to appropriate operating speed.



Machine Shutdown

- 1.) Allow plenty of time for insulation hose to empty.
- 2.) Move throttle control to slow position (give the fan time to slow down).
- 3.) Let engine cool down for 2 minutes before shutting off.
- 4.) Turn key to off position and remove from switch.
- 5.) Close fuel shut-off valve. **Note: If fuel shut-off valve is not closed, leakage may occur especially when transporting unit.**

See engine operation manual for additional starting and stopping instructions.

TROUBLE SHOOTING



Note: Whenever vacuum chamber cover is off, make sure key is taken out of the ignition switch and red positive cable is disconnected from battery.



Problem

Corrective Action

- 1) Gas vacuum will not start.
 - Check engine oil level - (if low, unit will not start).
 - Check engine fuel level.
 - Make sure there is no debris in the fan chamber impeding the motion of the fan.
 - Battery is low or dead. Manually start vacuum with rewind starter (Only on Briggs & Stratton). If vacuum runs, battery may need charged or replaced. If the battery is ok, electric starter may need serviced. (See engine operations manual.)
 - Make sure spark plug wires are attached.
 - Make sure fuel shut off valve is open.
 - Verify hoses are installed and limit switches are engaged.
 - Make sure spark plugs are clean and the correct plug for the appropriate engine is used. (If engine is not running properly, refer to engine owners' manual for proper troubleshooting.)

- 2) Excessive vibration.
 - Make sure unit is sitting on a level surface.
 - Make sure fan is properly secured to motor shaft.
 - Check fan for damaged fins.
 - Make sure there is no major insulation build up on the fan and in the chamber.
 - Fan may be out of balance and need replaced.
 - Loose bolts on fan chamber cover.
 - Check belt tension, tighten if necessary

- 3) Loud knocking or squealing.
 - Make sure fan is properly secured to motor shaft.
 - Make sure there is no foreign debris or insulation build up in the fan chamber.
 - Belt may be loose.

- 4) Gas vacuum loses horsepower.
 - Make sure there is no debris in fuel tank and fuel filter. Clean or replace.
 - Make sure there is no major insulation build up on the fan and in chamber.
 - Make sure air filter is clean, replace if necessary.
 - Check belt tension, tighten if necessary

- 5) Gas vacuum engine is stalling, smoking, or running irregularly.
 - Check engine fuel level - (Low fuel or no fuel).
 - Make sure fuel shut off is completely open.
 - Make sure gas vacuum is setting on level ground.
 - Improper fuel may have been used. **Use lead free gasoline with a minimum of 85 octane. Do not use gasoline which contains Methanol. This will deteriorate the fuel line. Refer to owners manual.**
 - Check for corrosion, build up, or foreign debris lodged in the float, pin, or seat.
 - Make sure engine oil level is not overfilled.
 - Make sure air filter is clean, replace if necessary.

Periodic preventive maintenance will add years of life to your equipment. Reviewing the information in this manual will go a long way in reducing downtime and lost income.

Krendl Machine Maintenance: Daily

- Clear insulation away from engine and muffler to avoid fire, ensure proper ventilation and reduce the chance of insulation getting in the fuel tank.
- **Do not** run vacuum inside of an enclosed box truck, trailer or building. Doing this will result in engine damage, exposure to carbon monoxide or fire.

Note: Debris can be sucked into the engine through the air intake and clog the cooling fins. (See Illust. E)

See engine operation manual for additional engine maintenance instructions and illustrations.

Briggs & Stratton



Air Intake

Honda



Air Intake

Access clean
out cover

Kohler



Air Intake

Illust. E

- Blow out engine cooling fins with compressed air. (See Illust. F) **Note: Failure to keep motor cooling fins clear of debris could result in catastrophic engine failure and voids warranty. (See Illust. G)**

Cooling
Fins

Briggs & Stratton



Cooling
Fins

Honda

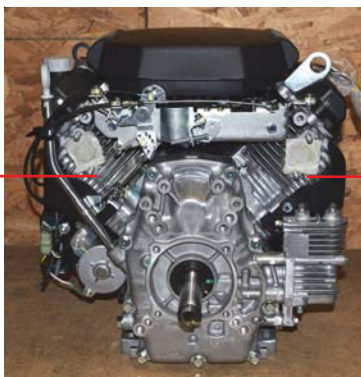

Cooling
Fins

Kohler



Cooling
Fins

Illust. F

- Make sure vacuum is on a level surface **outside** where the engine can receive fresh air and expel hot exhaust.

Weekly

- Remove air filter and blow with compressed air.
- Clean out fan chamber and remove insulation build up on fan.
- Inspect fan for wear and bent blades.

Note: Do not remove fan for general maintenance.

Monthly

- Check fuel tank and filter for debris and clean if necessary.
- Verify torque ratings on capscrews of taper lock bushing (192 inch pounds).

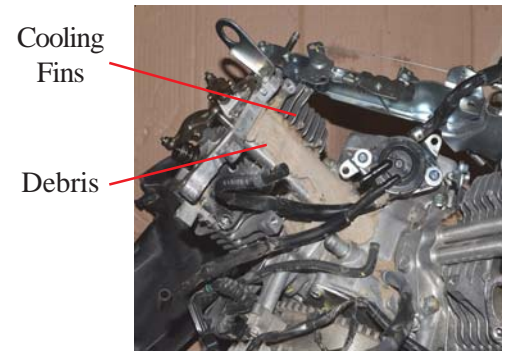

Illust. G

Engine Maintenance:

Important

- See engine manufacturer's manual for recommended maintenance schedule.

Every 8 Hours or Daily (Refer to operator's manual)

- Check oil level
- Clean around muffler, springs and linkages
- Inspect and blow out around cooling fins on cylinder heads

Briggs & Stratton Maintenance Schedule

Every 8 Hours or Daily
<ul style="list-style-type: none">• Check engine oil level• Clean area around muffler and controls
Every 100 Hours or Annually
<ul style="list-style-type: none">• Clean or change air filter *• Clean pre-cleaner (if equipped) *• Change engine oil and filter• Replace spark plug• Check muffler and spark arrester
Every 250 Hours or Annually
<ul style="list-style-type: none">• Check valve clearance. Adjust if necessary.
Every 400 Hours or Annually
<ul style="list-style-type: none">• Change air filter• Replace fuel filter• Clean air cooling system *• Clean oil cooler fins *

Kohler Maintenance Schedule

Maintenance Schedule	
Weekly	
<ul style="list-style-type: none"> • Check heavy-duty air cleaner element. 	
Every 25 Hours or Annually ¹	
<ul style="list-style-type: none"> • Service/replace low-profile precleaner. 	
Every 100 Hours or Annually ¹	
<ul style="list-style-type: none"> • Replace low-profile air cleaner element. • Change oil. • Remove cooling shrouds and clean cooling areas. • Check oil cooler fins, clean as necessary (if equipped). 	
Every 200 Hours	
<ul style="list-style-type: none"> • Change oil filter. • Replace fuel filter. 	
Every 250 Hours ¹	
<ul style="list-style-type: none"> • Replace heavy-duty air cleaner element and check inner element. 	
Every 500 Hours ¹	
<ul style="list-style-type: none"> • Replace heavy-duty air cleaner inner element. • Replace spark plugs and set gap. 	
Every 500 Hours ²	
<ul style="list-style-type: none"> • Have crankshaft spline lubricated. 	
¹ Perform these procedures more frequently under severe, dusty, dirty conditions.	
² Have a Kohler authorized dealer perform this service.	

Honda Maintenance Schedule

REGULAR SERVICE PERIOD (3) Perform at every indicated month or operating hour interval, whichever comes first.		Each Use	First Month or 20 Hrs	Every 6 Months or 100 Hrs	Every Year or 300 Hrs	Every 2 Years or 500 Hrs	Refer to Page
ITEM							
Engine oil	Check level	o					8
	Change		o	o			8
Engine oil filter	Replace		Every 200 Hrs.				9
Air cleaner	Check	o					9
	Clean			o (1)			9
	Replace					o *	
Spark plug	Check-adjust			o			10
	Replace				o		
Spark arrester (applicable types)	Clean			o (4)			11
Idle speed	Check-adjust				o (2)		**
Valve clearance	Check-adjust				o (2)		**
Combustion chamber	Clean		After every 1000 Hrs. (2)				**
Fuel filter	Replace				o (2)		**
Fuel tube	Check		Every 2 years (Replace if necessary) (2)				**

Hour / Tachometer Reset Instructions:

- 1) Toggle to the appropriate Flash Alert menu to be cleared.
- 2) Press and hold button until "00000" appears. (approx. 3 sec)

Note: Hour glass will flash repeatedly while holding button down during service reset.

Fan Removal for Replacement:

1. Remove fan chamber cover. (See Illust. H)
2. Remove cap screws and insert them in tapped holes in bushing flange.
3. Tighten cap screws progressively in a clockwise rotation placing equal amounts of torque until bushing disengages.
4. Remove fan from jack shaft.

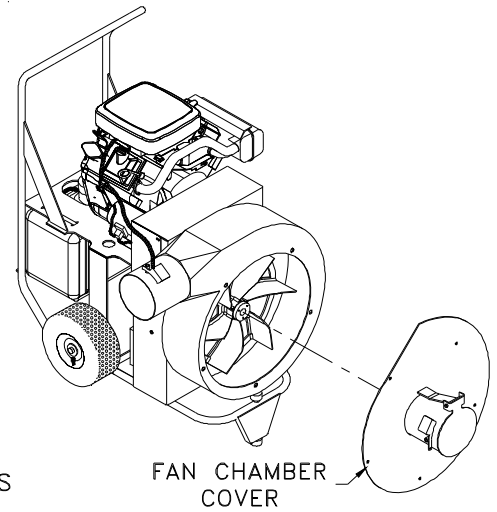
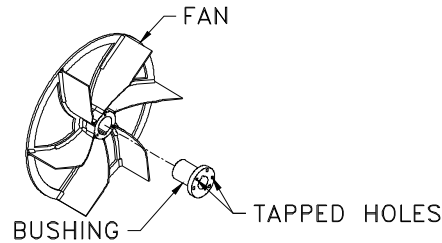

(Illust. H)

Fan Installation for Replacement:

1. Be sure the tapered cone surfaces of the bushing and the inside of the fan are clean and free of anti-seize lubricants.
2. Place bushing loosely into hub on fan. (See illust. I)
3. Start capscrews by hand, turning them just enough to engage the threads. **Note: Do not use a wrench at this time. Do not use anti-seize lubricant on tapered cone surfaces or on bolt threads when mounting fan to jack shaft.**
4. With key in shaft keyway, slide fan and bushing on to jack shaft. **Note: Make sure fan blades are facing outward and that the bushing is seated against the back step of the jack shaft. There should be approximately an 1/8" gap between the fan and chamber so they don't rub.** (See Illust. J)
5. Tighten capscrews progressively with a wrench in a circular direction to ensure equal tension as fan draws down on shaft to achieve 192 inch pounds torque. **Note: Do not attempt to pull bushing flange flush with hub end; some gap must remain between flange and hub after tightening.**
6. Install fan chamber cover and secure with bolts. (See Illust. H)

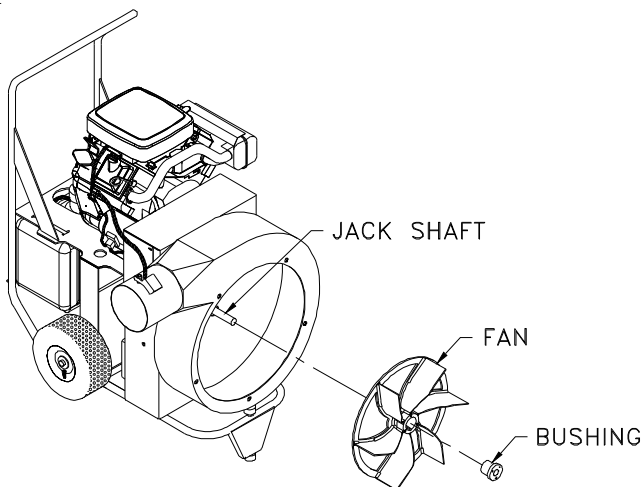

(Illust. I)

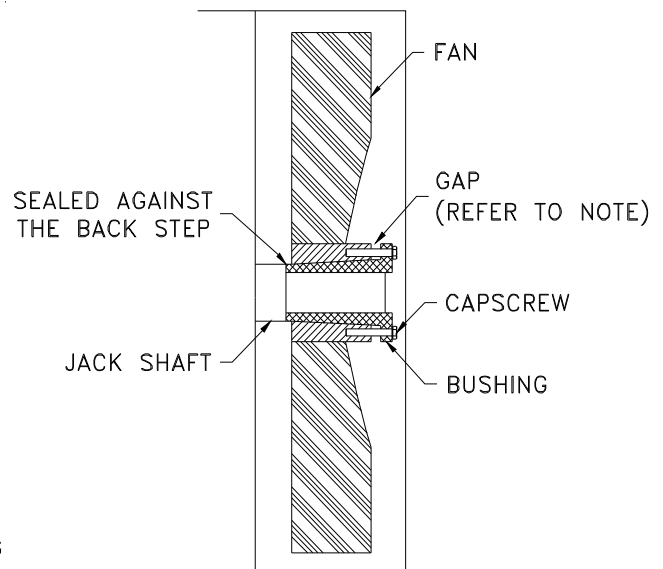

(Illust. J)

Bearings:

Bearings are prelubricated, double-sealed, self aligning ball bearings. They have grease fittings and should be periodically lubricated at least once a month. The lubrication schedule should be carefully followed. These bearings are filled with Mobil Mobilith SHC460 grease at the factory (18W suffix). This grease is a lithium-thickened lubricant having mineral base oil. The useable working temperature is -40°F to $+300^{\circ}\text{F}$. **Note: It is recommended to check to make sure the grease that is being used is compatible with the SHC460 grease as the mixing of incompatible grease can cause lubrication breakdown.** Proper lubrication intervals should be determined based on the observed condition of the purged lubricants. If the purged lubricants appear to be contaminated, then continue to purge the bearing until the lubricant is found to be in new condition. If bearings produce noise or heat (*too-hot-to-touch*), the bearings should be replaced.

Bearing Replacement:

Remove the four bolts from bearing flange and loosen (2) set screws on bearing hub. Since all set screws are installed with a medium grade Loctite, a propane hand torch maybe used to assist in removing them. Do not overheat unit, causing shaft to expand. A bearing puller can be used to remove the bearing. Eliminate any metal burrs from shaft with file and install new bearings with felt seals. Use a medium grade Loctite on set screws before securing bearing to shaft. (Check shaft diameter before ordering bearings)

Belt Removal for Replacement:

1. Remove belt guards. (See Illust. K)
2. Loosen 1/2" bolt on idler to relieve belt tension. (See Illust. L)
3. Remove (4) bolts and loosen (2) set screws on back bearing. (See Illust. K)
4. Remove back bearing and bearing shim.
5. Remove belt from pulleys and pull belt out through opening in frame. (See Illust. M & N) **Note: Pull top of belt towards chamber and bottom of belt out opening.**

Belt Guards

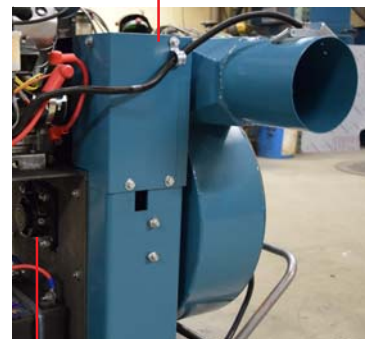

Bearing & Bearing Shim

(Illust. K)

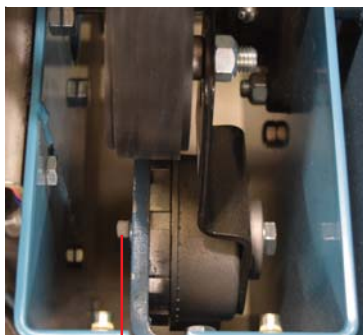

Idler Bolt

(Illust. L)

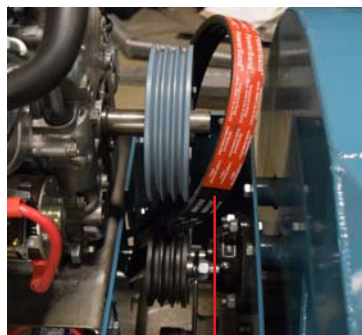

Belt

(Illust. M)



Opening

(Illust. N)

Belt Installation for Replacement:

1. Insert belt thru opening in frame. (See Illust. N)
2. Install bearing shim and bearing on to drive shaft. **Note: Eliminate any metal burrs from drive shaft and bearing.**
3. Place belt on pulleys.
4. Align all pulleys with straight edge and tighten (4) bearing bolts. (See illust. O) **Note: Turn bottom pulley by hand to make sure fan does not rub chamber.**
5. Using spanner wrench to adjust belt tension and tighten 1/2" idler bolt. (See illust. P) **Note: 1/2" bolt will need tightened when adjusting with spanner wrench.**
6. Install belt guards and secure with bolts.

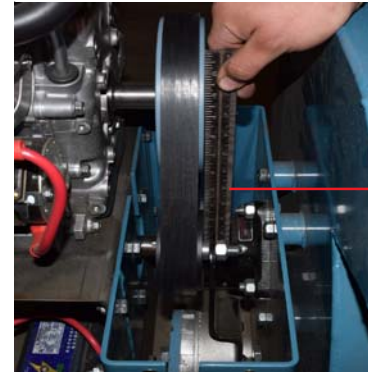

Straight
Edge

(Illust. O)

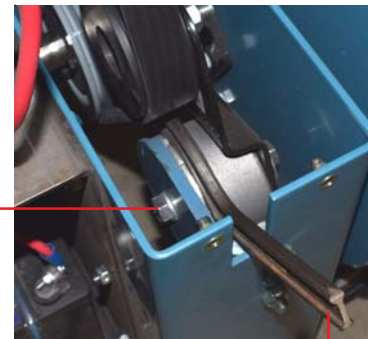

Idler Bolt

Spanner Wrench

(Illust. P)

GV230 Exploded Parts View

GAS VACUUM

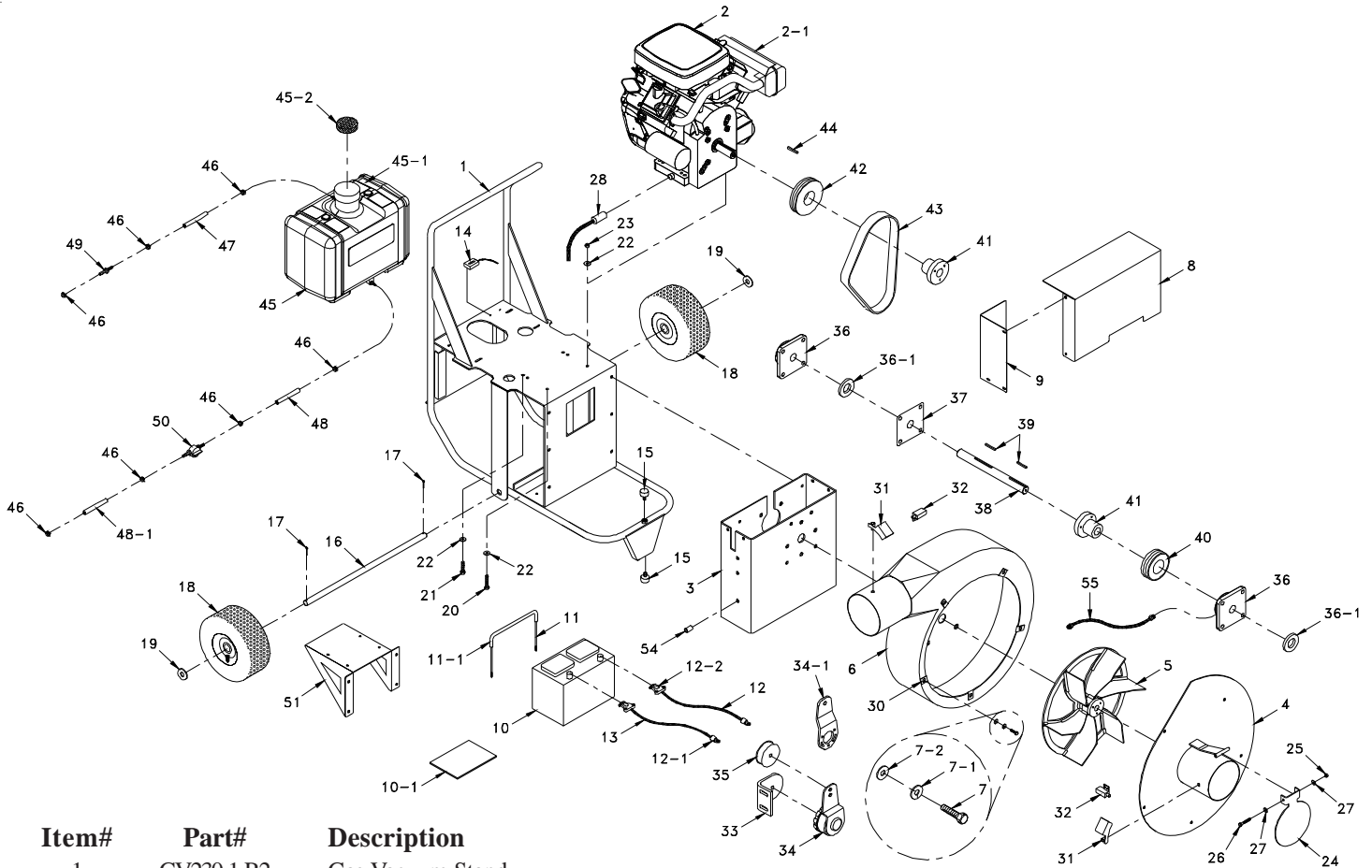

Item#	Part#	Description
1	GV230-1-R2	Gas Vacuum Stand
2	GV230-5	Motor, Gas Vacuum, 23HP
2	GV230-5H	Motor, Gas Vacuum, 22HP (Honda)
2	GV230-5K	Motor, Gas Vacuum, 23 1/2HP (Kohler)
2-1	GV230-5-1	Muffler Kit
2-1	GV230-5H-5	Muffler Kit (Honda)
2-1	GV230-5K-1	Muffler Kit (Kohler)
3	GV230-7	Mount, Fan Chamber
4	GV230-4-R1	Cover Plate, Fan Chamber
5	GV180-3-R4	18" Fan f/Gas Vacuum, Spoked
6	GV230-2-R3	Chamber, Fan, Gas Vacuum
7	FSB050	3/8-16 x 1" Hex Head (5)
7-1	FW006	W 3/8" Lock Washer (5)
7-2	FW007	5/16" Flat Washer (5)
8	GV230-9	Belt Guard
8	GV230-9-K	Belt Guard (Kohler)
9	GV230-10	Belt Guard Back
9	GV230-10-K	Belt Guard Back (Kohler)
10	GV230-28	Battery
10-1	GV230-17-R1	Battery Pad
11	GV100-14-R1	Hold Down, Battery
11-1	GV100-20-R1	Tubing, 17 1/2" (F/Hold Down)
12	GV230-18-R1	Battery Cable, Black, 13"

Item#	Part#	Description
12-1	ST301-6	Ring Terminal (2)
12-2	ST301-3	Connector, Battery Terminal (2)
13	GV230-19-R1	Battery Cable, Red, 27"
14	GV100-11	Hour Meter
15	GV100-8-R1	Vibration Isolater, Cart (2)
16	GV180-17-R1	Wheel Axle
17	150310	Pin, Cotter, 1/8" x 2" (2)
18	W-12	Wheel, 11", Flat Free (2)
19	FW030	3/4" Flat Washer-SAE (2)
20	FSB045	SB 5/16 - 18 x 2" HMS (2)
21	FSB042	SB 5/16 - 18 x 1 1/2" HMS (2)
22	FW007	5/16 Flat Washer (8)
23	FN014	N 5/16 - 18 Lock Nut-Crimped (4)
24	GV180-18	Guard, Inlet
25	FN005	N 1/4-20 Lock Nut-Crimped
26	FSB067	SB 1/4-20 x 3 1/4" HMS
27	FW003	W 1/4" Flat Washer (2)
28	4000-27/28	Drain Valve, Hose & Cap Kit
28	GV230-23H	Drain Valve, Hose & Cap Kit (Honda)
29	FSB191	SB 7/16 - 14 x 2" FHSCS (4) (Not Shown)
Note: Bolts connect the chamber to the motor.		
30	FC001	U-Nut Spring Clip Steel (5)
31	GV180-13-R1	Actuator Lever, Safety (2)
32	LS200	Switch, Limit, (2)
33	GV230-6	Idler Bracket
33	GV230-6-K	Idler Bracket (Kohler)
34	5200-22	Tensioner, H.D., Rotary
34-1	GV230-33	Tensioner Arm
35	5200-97	Idler, 3GR3V3.35
36	GV230-16	Bearing, 4-Bolt, 1 1/8" I.D. (2)
36-1	250503-7	Seal, Felt, 1 1/4" (2)
37	GV230-11	Bearing Shim
38	GV230-3	Shaft, Belt Driven
39	109080	Key, 1/4" x 1/4" x 2 1/8" (2)
40	GV230-14	Sheave 5" 3-Groove
41	GV230-12	Bushing 1 1/8" (2)
42	GV230-13	Sheave 6 1/2" 3-Groove
43	4000-19	Belt 3/VX375, 37 1/2" Long
43	5200-38	Belt 3/3VX425, 42 1/2" Long (Kohler)
44	150311Z	Key, 1/4" x 1/4" x 1 3/4"
45	28-36	Tank, 5 Gallon
45-1	RM-CT0048	Cable, Tie, 48" Long (2)
45-2	28-57	Filter, Fuel
46	104	Clamp, Pinch (7)
47	RM-OTH202-EPA	1/4" Fuel Line, 48" Long
48	RM-OTH202-EPA	1/4" Fuel Line, 22" Long
48-1	RM-OTH202-EPA	1/4" Fuel Line, 8" Long
49	23001	Barb, 1/4" x 3/16" Splicer, Plastic
50	BS-230	Fuel Shut Off, Inline 1/4"
51	GV230-24-R1	Bracket, Support
52	RM-OTH205-MI	Tubing, Flex/Split 3/8", 93" Long (not shown)
53	4000-46	Rubber Grommet, 1" (not shown)
54	GV230-30	Coupling, 1/8" FNPT
55	KS200-4	Hose, F/Grease Gun, 12" Long, 1/8" NPT



60 YEARS OF AMERICAN INGENUITY

Made in the U.S.A.

**KRENDL MACHINE COMPANY • 1201 SPENCERVILLE RD
DELPHOS, OHIO 45833 • TELEPHONE 800-459-2069 • FAX 419-695-9301
E - MAIL: krendl@krendlmachine.com • WEB SITE: www.krendlmachine.com**
